

# STRUCTURE DESIGN INSTRUCTION

## 1. SUMMARIZE

1.1 Foundation design according to following files:

(1) Extreme load for foundation design:

Load case	MX		MY		MXY		MZ		FX		FY		FXY		FZ		Safety factor
	Max	Min	Max	Min	Max	Min	Max	Min	Max	Min	Max	Min	Max	Min	Max	Min	
MX	Max	63E	18720	11940	22204	2579	286.3	-373.3	470.4	-1042.1	1.35						
MX	Min	63E	-14901	2504.6	15110	-390.3	77.9	357.5	365.9	-1012.9	1.35						
MY	Max	63E	15456	2772E	31218	-80.0	659.1	-344.9	743.9	-1060.4	1.35						
MY	Min	63E	-3431.6	-315.7	5513.7	-54.9	-81.5	83.2	116.5	-1017.2	1.35						
MXY	Max	63E	15456	2772E	31218	-80.0	659.1	-344.9	743.9	-1060.4	1.35						
MXY	Min	63E	-12.8	-6.8	14.5	-3.2	10.4	-5.7	11.8	-1020.9	1.1						

(2) Geotechnical report of every site.

(3) 《Code for design of building foundation 》GB50007-2002

(4) 《Code for design of concrete structure 》GB50010-2002

(5) 《Code for design of high-rising structure 》GB 50135-2006

(6) Other drawing from GOLDWIND.

2. structure design summarize

structure design working life	safety classes of structure	Classifications of seismic fortification	fortification intensity
25 year	class II	category C	6

Design basic acceleration of ground motion	dynamic factor
0.05g	1.35

## 2. SUBGRADE AND FOUNDATION

2.1 Subgrade treat and foundation design was performed according to geotechnical investigation of the project.

2.2 Choosing natural subgrade and subsoil bearing capacity is required over 300 KPa.

## 3. MATERIAL

3.1 Concrete strength grade : underlayer : C15, principal part : C30 ;

Requirement of concrete material as following table:

Max. water-cement ratio	Min.cement consumption (kg/m <sup>3</sup> )	Max.chlorion content (%)	Max.alkali content (kg/m <sup>3</sup> )
0.65	275	0.2	3.0

3.2 Characteristic values of strength for ordinary steel bars (N/mm) shall be adapted from table below from code GB 1499. The guarantee rate for characteristic values of strength for steel bar shall not be less than 95%.

types	symbols	f <sub>yk</sub>
Hot rolled	HRB335	Φ
steel bar	HRB400	Φ
		400

## 4. REINFORCED CONCRETE STRUCTURE

4.1 Reinforced concrete cover of foundation is 50mm.

4.2 Connection of steel reinforcement when the diameter of steel reinforcement is d≥20mm ,mechanical connection should be adopted.

when binding lapped splice joint was used, the length of lapped splice and the percentage of area for lapped splice joint in steel reinforcement should obey corresponding requirement of 《Code for acceptance of constructional quality of concrete structures 》GB 50204-2002.

4.3 The check and accept of steel reinforcement should be performed by code GB50204 after arrangement and binding.

NAME GOLDWIND TYPE S50/750 TOWER 50m IEC 11A

STRUCTURE DESIGN INSTRUCTION

EDITION

1

CATEGORY CONCRETE STRUCTURE

NO.

01

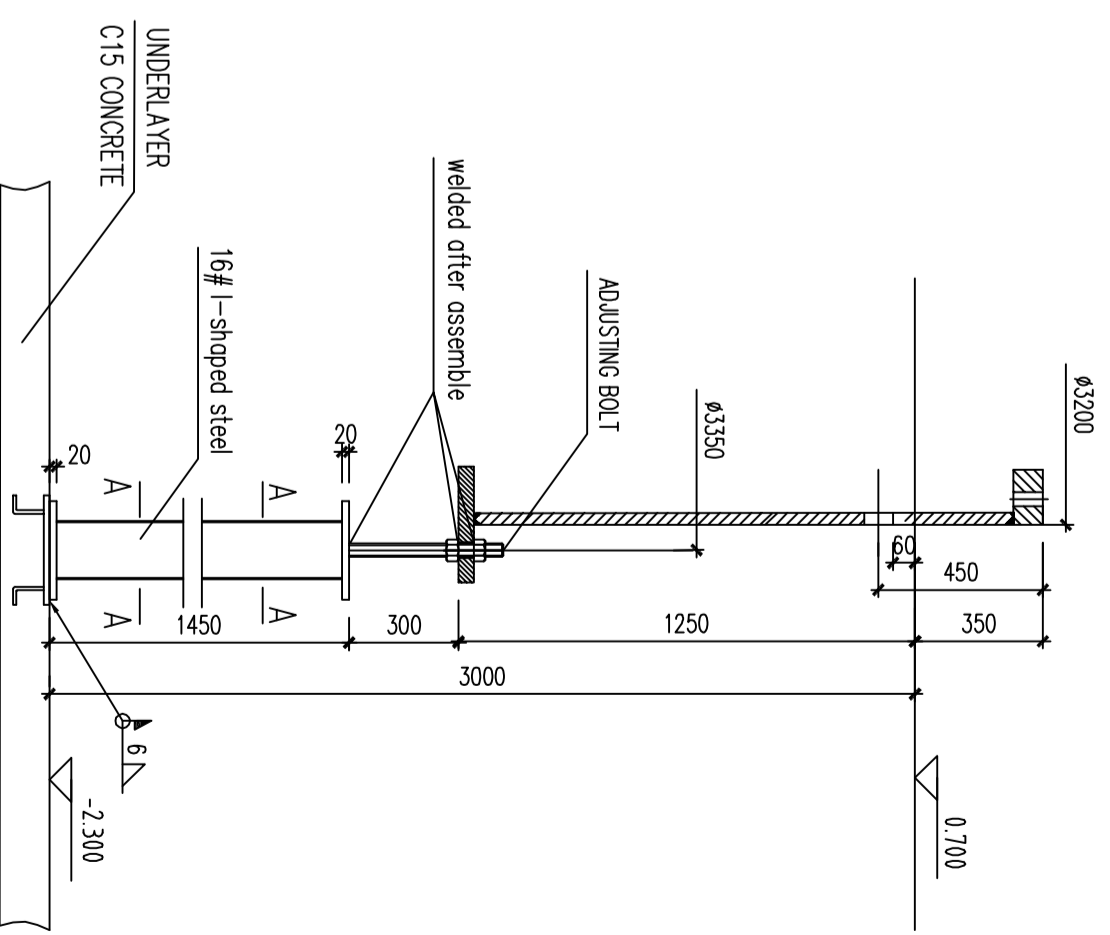
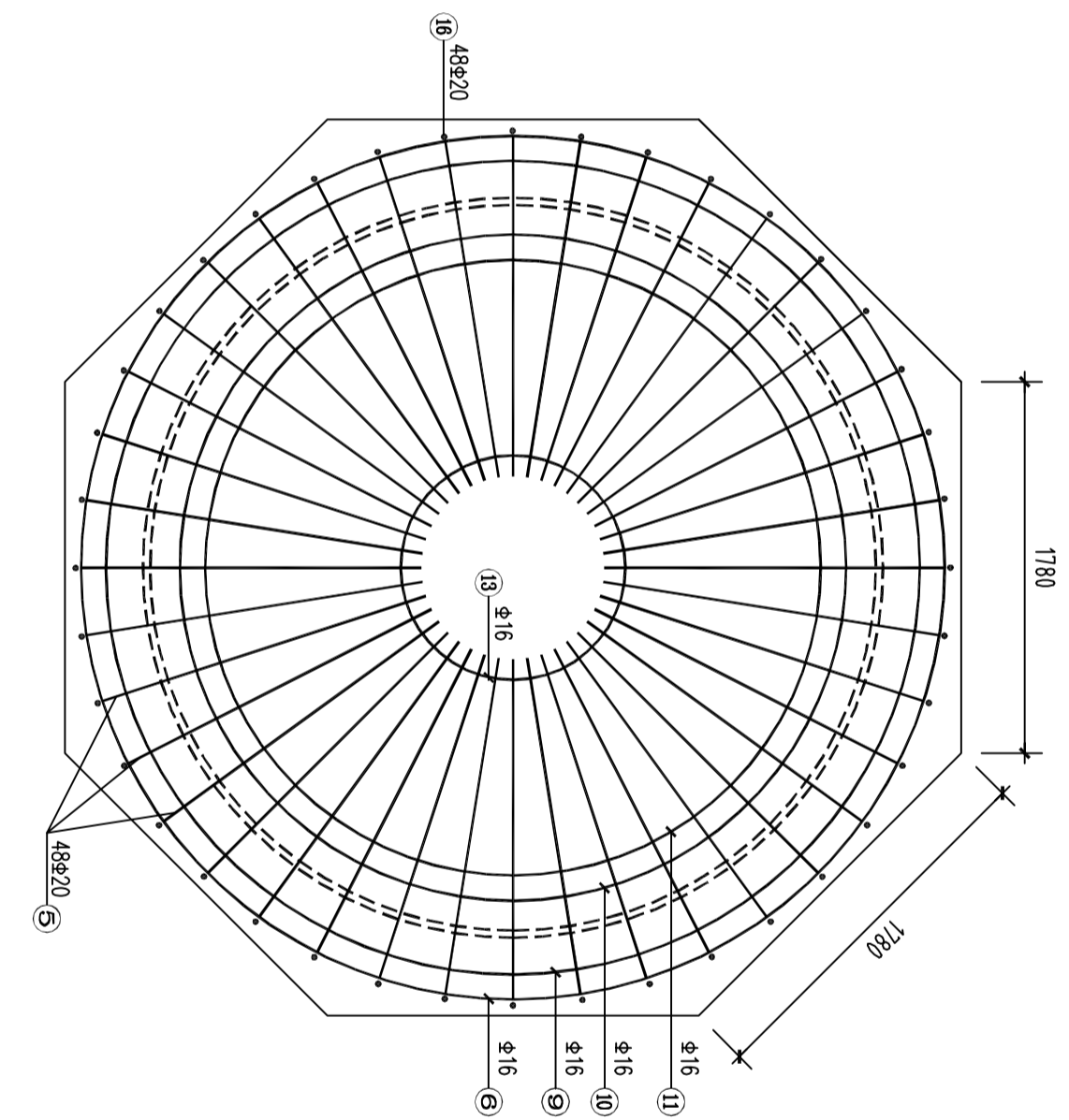
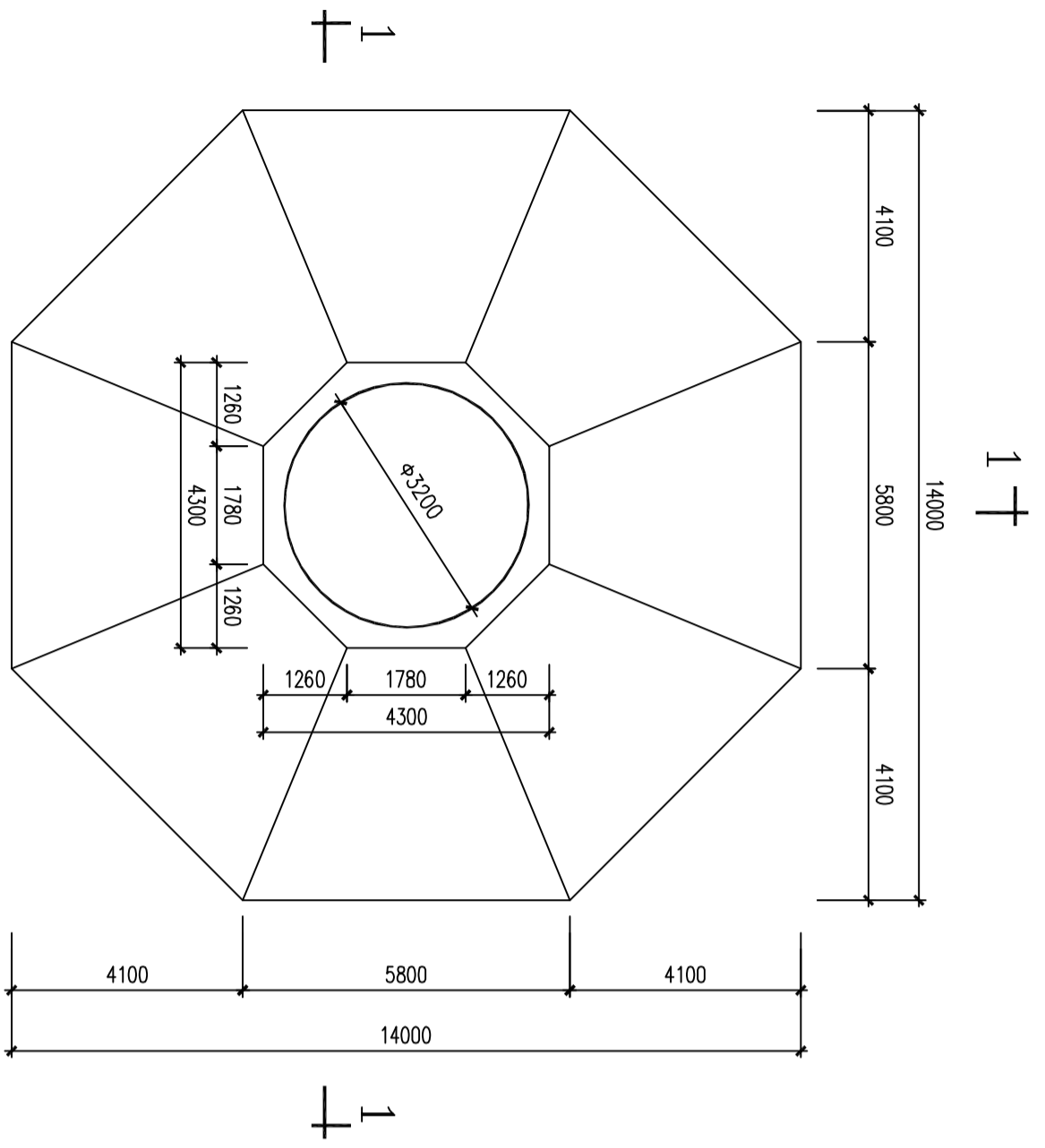

TOP VIEW OF FOUNDATION

2-2 PROFILE

THE VIEW OF SUPPORTER

NOTE :  
1. There are 3 supporter under the foundation ring, connect each other if it is not steady enough.

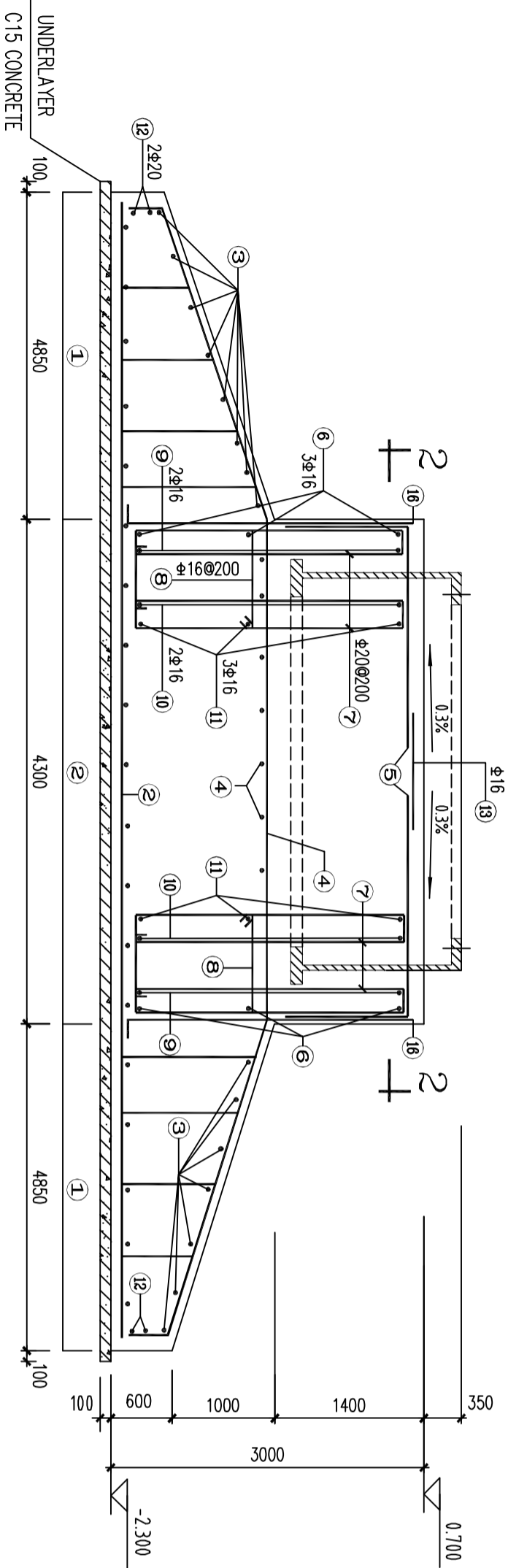

1-1 PROFILE

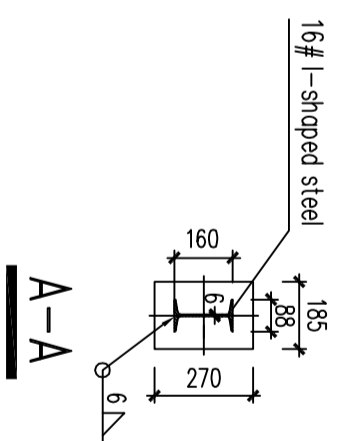

NAME	GOLDMIND TYPE S50/750 TOWER 50m IEG 11A
STRUCTURE DESIGN INSTRUCTION	
EDITION	1
CATEGORY REINFORCEMENT ARRANGEMENT	
NO.	02

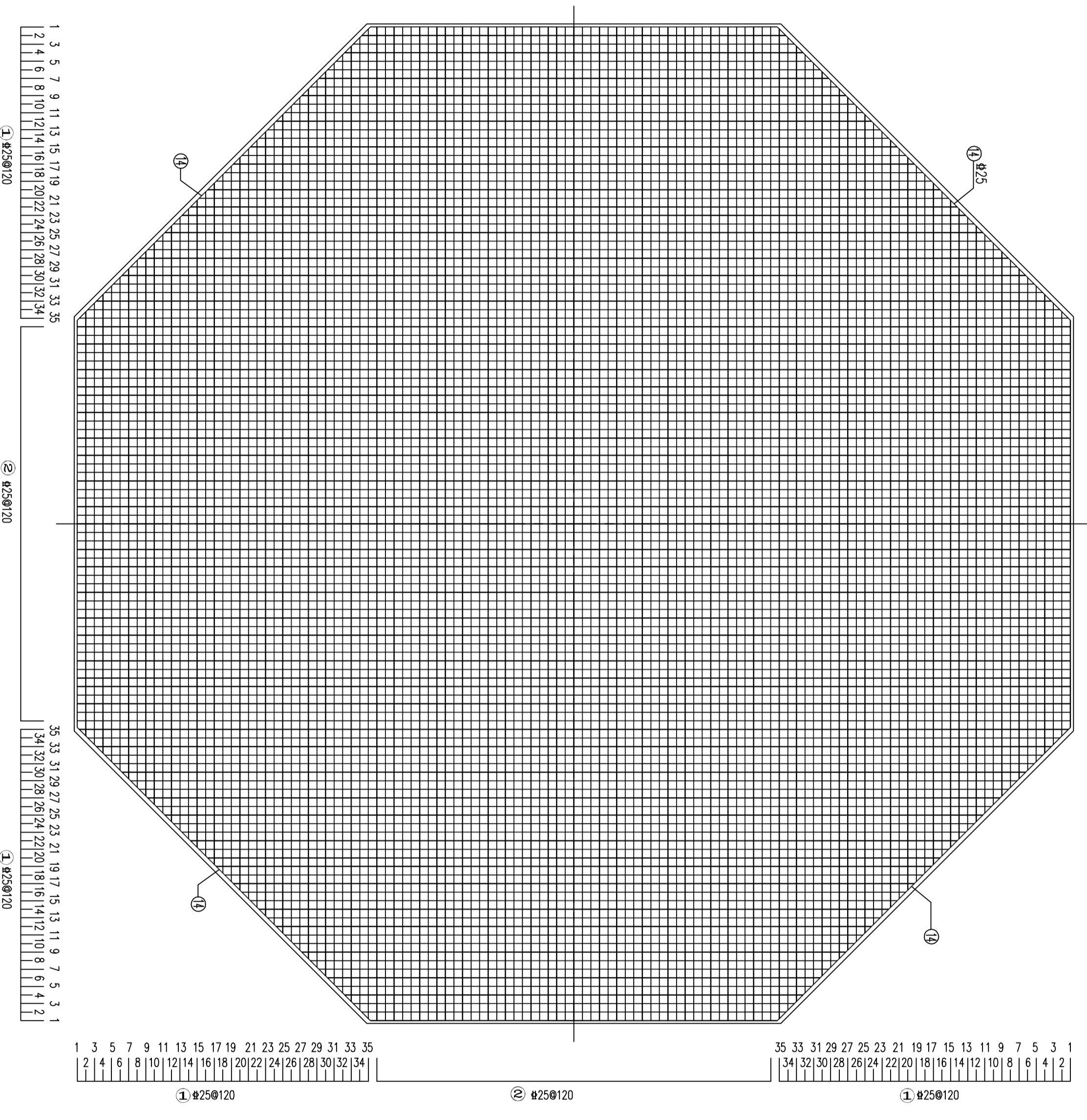

BOTTOM REINFORCEMENT

NAME	GOLDMIND TYPE S50/750 TOWER 50m IEG 11A
STRUCTURE DESIGN INSTRUCTION	
EDITION	1
CATEGORY	BOTTOM REINFORCEMENT
NO.	03

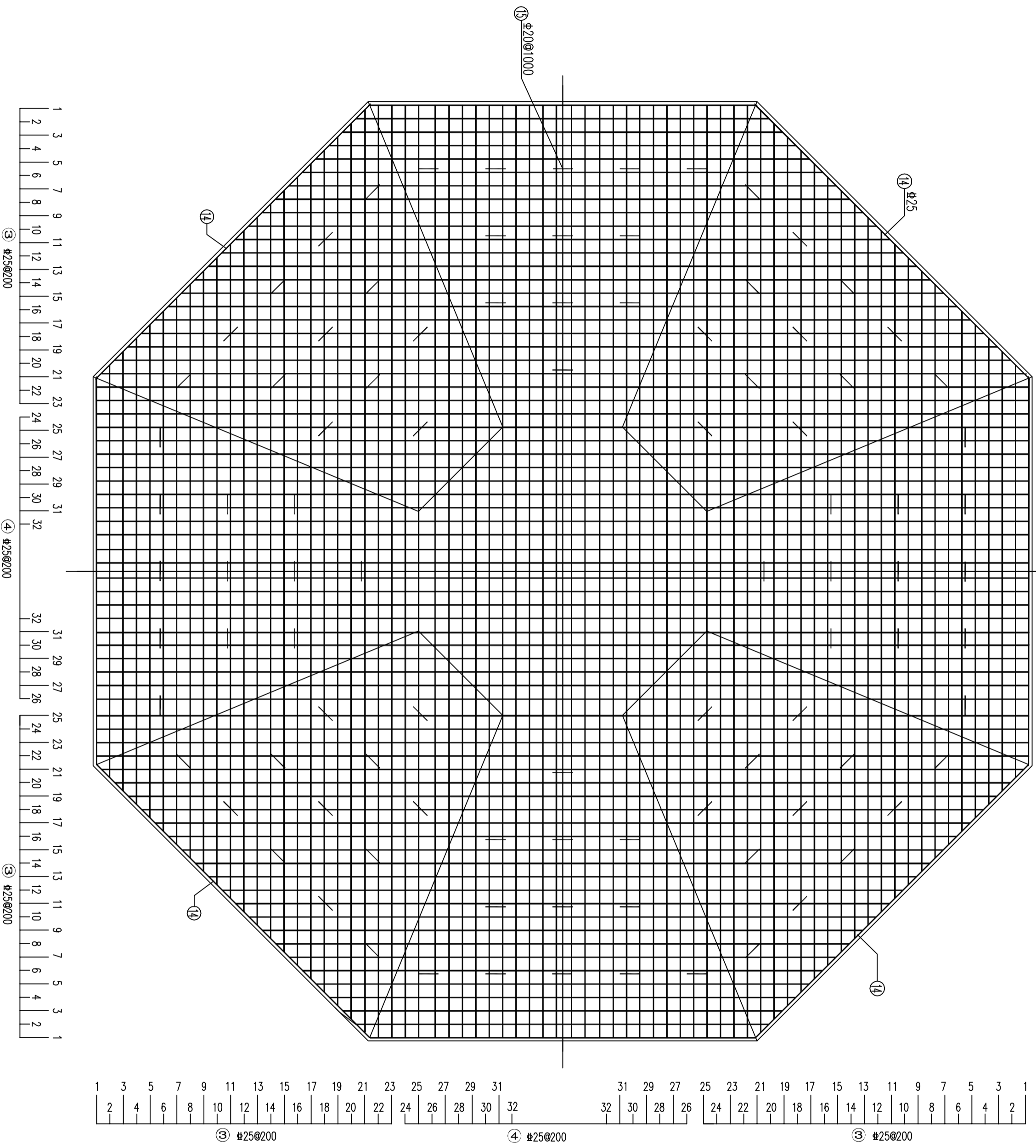

TOP REINFORCEMENT

NAME	GOLDMIND TYPE S50/750 TOWER 50m IEG 11A
STRUCTURE DESIGN INSTRUCTION	
EDITION	1
CATEGORY	TOP REINFORCEMENT
NO.	04

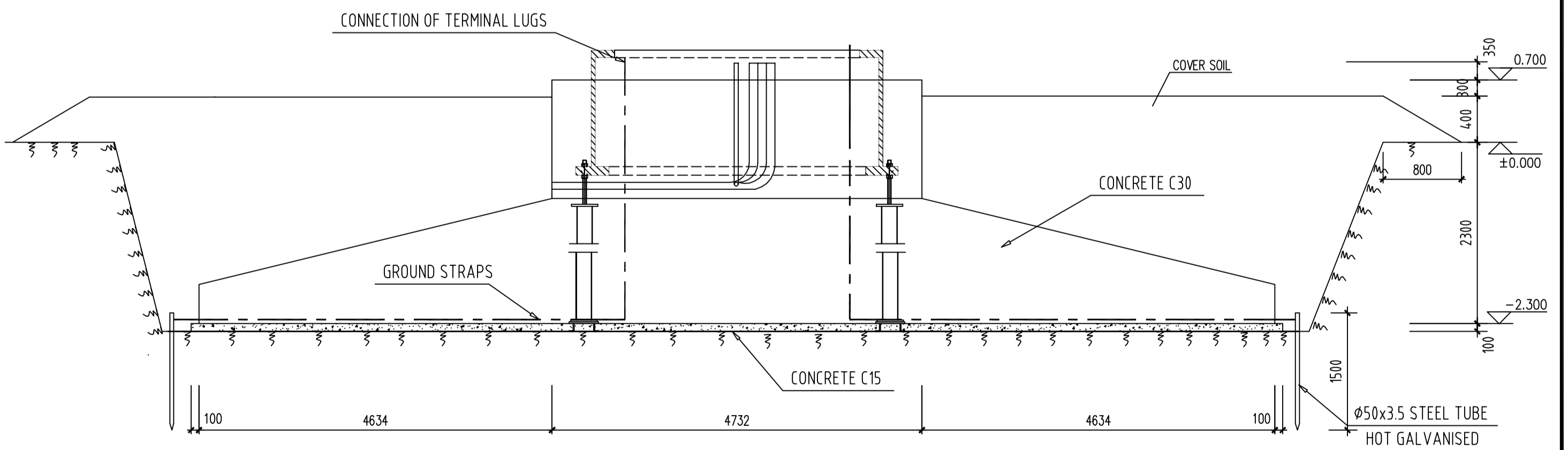
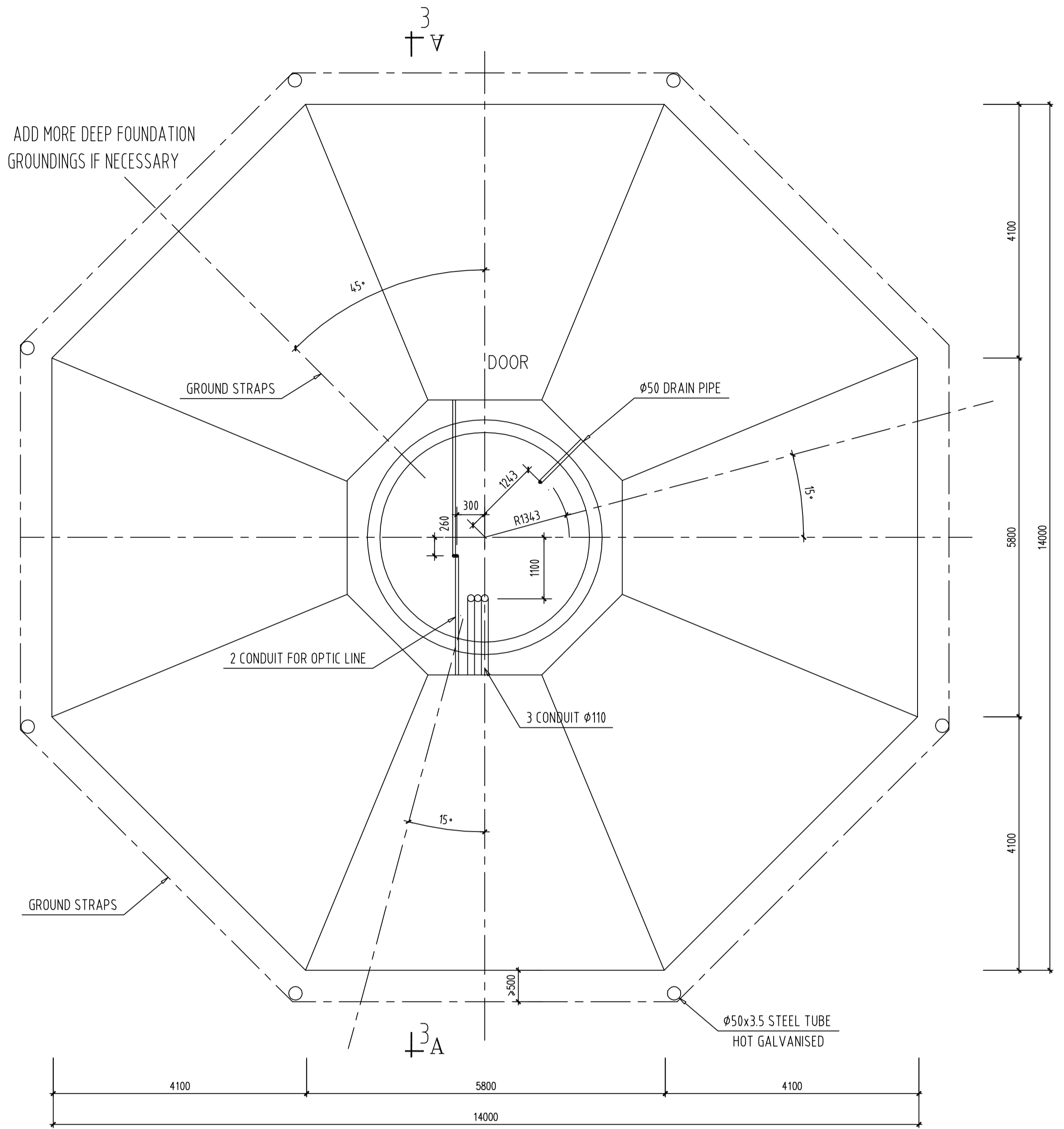

NAME	GOLDWIND TYPE S50/750 TOWER 50m IEC 11A
	STRUCTURE DESIGN INSTRUCTION
EDITION	1
CATEGORY	REINFORCEMENT ARRANGEMENT
NO.	05

## STEEL SCHEDULE

NO.	SHAPE	DIAMETER	COUNT	LENGTH	NOMINAL WEIGHT (Kg/m)	OVERALL WEIGHT (Kg)
①	X	Φ25	140	SEE BARS IN 1 LAYER	3.850	5274.1
②	13900	Φ25	94	13900	3.850	5030.4
③		Φ25	100	SEE BARS IN 1 LAYER	3.850	4428
④		Φ25	40	SEE BARS IN 1 LAYER	3.850	2330
⑤	1650	Φ20	48	2850	2.466	337.3
⑥		Φ16	3	16553	1.578	78
⑦		Φ20	116	6560	2.466	1876.5
⑧		Φ16	58	5080	1.578	465
⑨		Φ16	2	14907	1.578	47
⑩		Φ16	2	11950	1.578	38
⑪		Φ16	3	10407	1.578	49
⑫		Φ20	16	6730	2.466	265.5
⑬		Φ16	1	6900	1.578	10.9
⑭		Φ25	4	6345	3.850	97.7
⑮		Φ20	24 24 40	X(mm) 1030 815 600	2.466	598.9
⑯	2900	Φ20	48	3000	2.466	355.1
OVERALL WEIGHT OF STEEL BARS						21379

## BARS IN 1 LAYER

軸持	X(mm)	軸持	Y(mm)	軸持	X(mm)	軸持	X(mm)
1	5705	15	9065	29	12425		
2	5945	16	9305	30	12665		
3	6185	17	9545	31	12905		
4	6425	18	9785	32	13145		
5	6665	19	10025	33	13385		
6	6905	20	10265	34	13625		
7	7145	21	10505	35	13865		
8	7385	22	10745				
9	7625	23	10985				
10	7865	24	11225				
11	8105	25	11465				
12	8345	26	11705				
13	8585	27	11945				
14	8825	28	12185				

③

軸持	X(mm)	Y(mm)	H(mm)
1	5757	71	10
2	5591	287	50
3	5425	573	89
4	5259	858	129
5	5093	1144	168
6	4927	1429	208
7	4761	1715	248
8	4595	2000	287
9	4429	2286	327
10	4263	2571	366
11	4097	2857	406
12	3931	3143	446
13	3765	3428	485
14	3599	3714	525
15	3433	3999	564
16	3267	4285	604
17	3101	4570	644
18	2935	4856	683
19	2769	5141	723
20	2603	5427	762
21	2437	5713	802
22	2271	5921	842
23	2105	6009	881
24	1939	6097	921
25	1773	6184	960

④

軸持	X(mm)	Y(mm)	H(mm)
26	2181	5986	990
27	2581	5740	990
28	2981	5543	990
29	3381	5346	990
30	3781	5149	990
31	4181	4953	990
32	4300	4944	990

NO.	ITEM	UNIT	COUNT
1	EXCAVATING	m <sup>3</sup>	614.1
2	UNDERLAYER CONCRETE	m <sup>3</sup>	16.71
3	PRINCIPAL CONCRETE	m <sup>3</sup>	202.02
4	STEEL BARS	t	21.379

NAME GOLDMIND TYPE S50/750 TOWER 50m IEG 11A  
STRUCTURE DESIGN INSTRUCTION

EDITION 1  
CATEGORY STEEL SCHEDULE  
NO. 06