



Danish Wind Technology

Smed Hansens Vej 27 • DK-6940 Lem • Danmark • Tel. +45 97 34 11 88 • Telefax +45 97 34 14 84 • Telex 60 733 vestas dk

Product Description

Vestas V20-120 kW

Stall Regulated

The V20-120 kW is derived from the robust, reliable and well proven Vestas V17-90 kW wind turbine which has shown its strength all over the world.

The service friendly lay out in modules is continued in the V20-120 kW which is a three blade stall regulated wind turbine with a single generator.

The V20-120 kW is in the following described in main areas:

- | | |
|-----------------------------|-----------------------------|
| 1. Machine build up | 10. Delivery conditions |
| 2. Lattice tower/Tower | 11. Connection instructions |
| 3. Engine room | 12. Warranty |
| 4. Blades | 13. Service |
| 5. Braking system | 14. Insurance |
| 6. Cable | |
| 7. Safety equipment | |
| 8. Controller | |
| 9. Main data for components | |

1. Machine Build-Up

The wind turbine is built up around a strong bed frame (1) which is made from sectional iron piping and steel plate in order to place all weldings in low load areas.

The forged main shaft (2) is fitted with two spherical roller bearings each placed in its own welded up bearing housing which with a bearing pipe between them. This build up is acting as a unit and takes up both radial and axial forces from the rotor. This construction ensures extra large grease volumes around shaft and bearings which according to experience gives a long and trouble free lifetime.

The cast blade hub (3) is bolted onto the main shaft. The blades (4) are bolted onto the blade hub.

At the end of the main shaft the two stage gearbox with parallel shaft is fitted with a clamping element.

The disc brake (5) is placed on the low speed shaft and is fitted with 4 hydraulic brake callipers and asbestos free brake pads. The placing of the brake disc means a minimal load on the gearbox during braking.

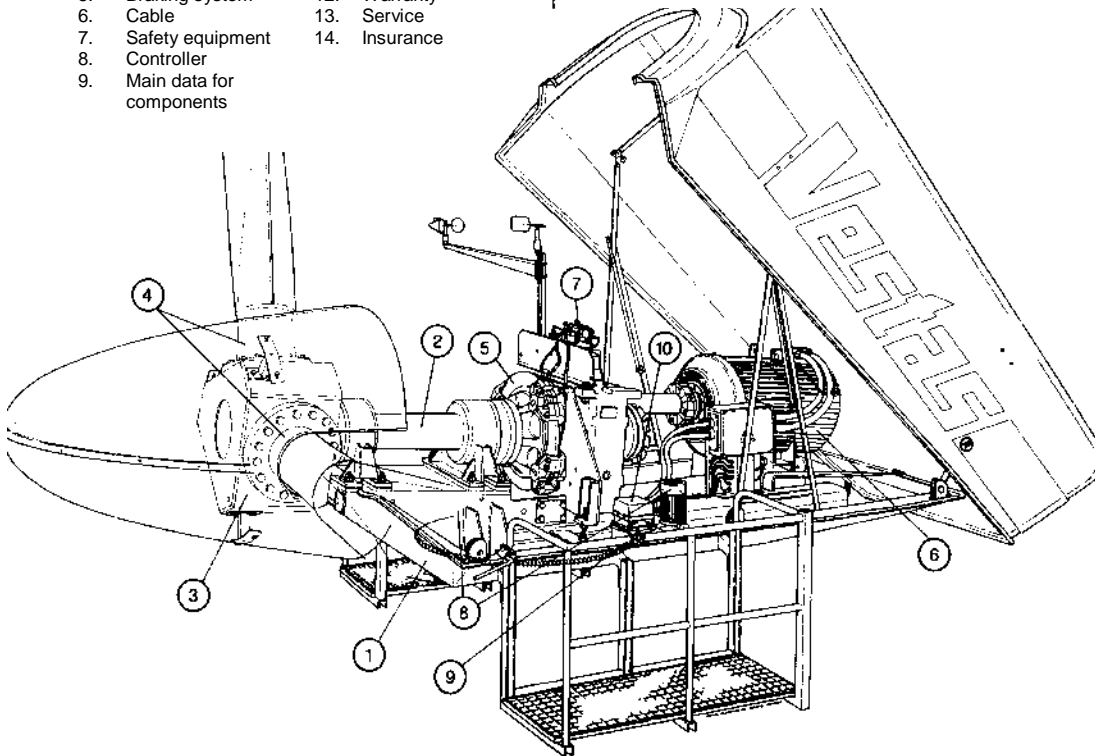

The generator (6) is driven from the high speed shaft of the gearbox through two flexible couplings.

The hydraulic unit (7) provides oil pressure to the brake callipers.

Yawing is carried out by two electrically driven yaw motors through double worm gears (8) placed on each side of the bed frame and engaged with the yaw ring (9).

This solution divides the load equally on the two yaw gears. The yawing is controlled by an electronic wind vane. The wind turbine is protected against cable twisting by the yaw guard (10).

The bed frame is fitted onto the yaw plate with a polyamide ring and is kept axially and radially in place by a ball bearing. The yaw plate is bolted to the top of the tower/lattice tower.

The chosen engine build up gives a well arranged and reliable machine with easy access to service and maintenance. This will over time ensure lower maintenance costs.

2. Tower/Lattice Tower

The V20-120 kW can be delivered with either a galvanized lattice tower or a metallized and white painted closed steel tower.

The closed tower is fitted with doors which gives access to both the blade tip brakes and the two work platforms placed on each side of the bed frame.

In the closed tower lamps and power outlets are fitted.

3. Engine Room

The engine room is shielded with a fiberglass cover. This cover provides protection to the engine room components against the weather. The cover furthermore reduces the noise level from the wind turbine during operation.

At the same time the cover allows sufficient cooling air to flow through the engine room to cool off the gearbox and generator.

The cover which is hinged in a special open-close mechanism can be opened and thereby give access to the engine room for the carrying out of service and maintenance.

4. Blades

The blades are manufactured from glass fiber reinforced polyester. The blade shells are assembled in a light sandwich construction and placed around a central load carrying rod which in the root end is provided with a number of embedded special nuts.

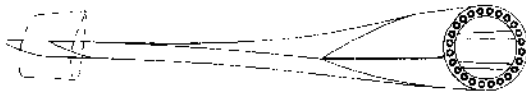

The blades which are bolted to the blade hub are constructed and manufactured by Vestas in order to have the best possible balance between the demands for wind/power efficiency and a minimal load on the wind turbine itself. This should ensure the longest possible lifetime of the wind turbine.

5. Braking System

The V20-120 kW is provided with two independent braking systems.

Hydraulic Disk Brake

The brake disc which is mounted on the main shaft is provided with 4 powerful brake callipers. This braking system can bring the wind turbine to stop during all controlled operational conditions.

Blade Tip Brakes

In the occurrence of an error in the controller and/or the hydraulic system and the thereby following overspeed on the rotor the centrifugal force will activate a mechanism which will let out the blade tips and thereby preventing the rotor from running up to fatal speeds.

When the blade tips are activated the rotor speed can never exceed the normal operational rotor speed.

6. Cable

The wind turbine is provided with the necessary and sufficient wiring and cabling to connect it to the wind turbine controller situated at the bottom of the lattice tower/closed steel tower.

The cables from the grid including main breaker, fuses etc. are connected to the outlets of the wind turbine controller and are NOT included in the delivery from Vestas.

7. Safety Equipment

Vestas wind turbines are equipped with safety equipment that meets the legislation from the Danish safety at work commission at the time of the ordering of the wind turbine.

8. Controller

A microprocessor based controller is monitoring and controlling all critical functions in the wind turbine. The controller gives access to data about the operation and condition of the wind turbine.

The connection of the generator to the grid is performed by thyristors. After the generator is successfully connected to the grid the thyristors are disconnected and an electrically activated contactor is engaged.

The controller gives access to remote control and remote monitoring of the wind turbine. This feature is optional and not included in the standard wind turbine.

9. Main Data

Rotor:

Diameter	20 m
Swept area	314 m ²
Rotor RPM	46 rpm
Rotor direction	Clockwise
Power regulation	Stall
Number of blades	3
Blade material	Glass fiber reinforced polyester
Blade brake	Blade tip turns and brakes when activated
Blade profile	NACA 44
Hub height	24 m
Manufacturer	Vestas

Operational data:

Start wind speed	4,5 m/s
Stop wind speed	25,0 m/s
Rated power at	13,0 m/s

Lattice tower:

Type	Lattice tower
Accessories	Foundation bolts Casting template Foundation drawing
Surface	Galvanized
Height	23,4 m
Manufacturer	Carl C. Jensen or similar

Steel tower:

Type	Conical steel pipe tower
Accessories	Galvanized foundation section with bolts and foundation drawing
Surface	Metallized and painted white
Height	23,4 m
Manufacturer	Roug or similar

Generator:

Type	asynchronous
Rated power	124 kW
Rated current	176 A
Voltage	480 V AC
Frequency	60 Hz
Power factor (cos φ)	0,85
Connection	Triangle
Insulation class	F
Safety class	IP 54
Temperature protection	PT 100
Revolutions	1200 rpm
Manufacturer	Siemens, AEG or similar

Gearbox:

Type	Two stage
Ratio	1:22
Rated power	195 kW
Manufacturer	Hansen or similar

Yaw system:

Type	Active yawing
Control	Wind vane
Speed	1 degree/sec

Yaw motors:

Type	Asynchronous motor
Revolutions	1450 rpm
Rated power	0,55 kW
Manufacturer	Grundfoss or similar

Yaw gear:

Type	Double worm gears
Manufacturer	B. J. or similar

Wind vane:

Type	Opto electrical
Manufacturer	Vestas

Hydraulic unit:

Type	Piston pump
Max system pressure	135 bar
Manufacturer	Have

Controller:

Type	Microprocessor
Manufacturer	Vestas

Weights:

Conical closed steel tower	5600 Kg
Lattice tower	4300 Kg
Machine	4600 Kg
Rotor	1700 Kg

The above listed specification can be changed by Vestas without warning.



Danish Wind Technology

Smed Hansens Vej 27 • DK-6940 Lem • Danmark • Tel. + 45 97 34 11 88 • Telefax + 45 97 34 14 84 • Telex 60 733 vestas dk

11. Delivery Conditions

The wind turbine as described in the previous sections is delivered, assembled, erected and run into normal automatic operation on the from the buyer supplied foundation after that the buyer has arranged connection to the grid according to the below mentioned conditions.

12. Connection Instructions

The placing of the controller housing.

The controller housing which is manufactured from metal with corrosion protection is not water proof and must therefore be protected against water.

When the turbine is erected on a closed steel tower the controller housing can be placed inside the tower. When the turbine is erected on a lattice tower the controller can be placed in a little shed situated between the "legs" of the lattice tower.

Dimensions of the controller housing

Depth	400 mm
Height	1200 mm
Width	800 mm

Distance between hanging-up-points

Horizontal	1280 mm
Vertical	760 mm

There should be at least 800 mm between the bottom of the controller housing and the ground in order to make possible to fir the grid cables.

Connection to the grid

The connection to the public grid is carried out by using copper or aluminium cables through a lockable electrical breaker fitted by Vestas in the controller housing.

The service line must be able to carry at least 200 A and must have 200 A rapid fuses added. The dimensions of the cables are depending on length and material.

The connection terminals in the controller housing are copper terminals with the possibility of connecting cable shoes with 10 mm holes. Screw caps for the connection cables through the bottom of the controller housing are PG 48.

Earthing

The wind turbine and the controller are earthed using 1 x 25 mm² cable connected to an earth electrode with a resistance of max 10 Ohms.

Light in tower

In the controller housing there is a possibility of getting 220 V power supply to light in the tower.

Power measurement device

The power measurement device can often be placed together with the main breaker. It must however be cleared with the local electricity company.

Responsibility

It must be underlined that the connection of the Vestas supplied controller to the grid is the responsibility of the local certified electrician. This service is not included in the Vestas delivery.

Vestas will of course give advice if necessary.

Grid reinforcement

If grid reinforcement is necessary it should be noted that this is not included in the Vestas delivery.

Foundation

Vestas is only delivering standard drawings and descriptions for the construction of the foundation.

Vestas is delivering the foundation section to wind turbines to be erected on a closed steel tower and casting template to wind turbines to be erected on lattice tower.

Casting templates are the property of Vestas and must be returned after use.

Soil analyses and special foundation calculations, drawings and construction of the foundation are not included in the Vestas delivery.

Road to turbine

It is a condition for the delivery that a solid road to the erection site is established. All costs relating to this are of no concern of Vestas. This also applies for the following period with warranty and service.

13. Warranty

år

Vestas offers a 2 year warranty covering faults in construction and materials providing that the wind turbine is used in accordance with the Vestas operator's manual.

14. Service

A free 2-year service and maintenance period comprising service inspections every 3, 12 and 24 months according to the Vestas service manual is included in the Vestas delivery.

The consumption of wear parts and lubricating fluids are not included in the Vestas delivery.

A service and maintenance contract can be signed after the 2 year warranty period has run out.

15. Insurance

A 5-year wind turbine insurance including insurance against loss of production offered by a known insurance company can be signed.

Insurance is not included in the Vestas delivery.