



Wind Power Inverter  
**WINDY BOY 2500 / 3000**  
Installation Guide



**MWPS World**

# Table of Contents

<b>1</b>	<b>Notes on this Manual.</b>	<b>6</b>
1.1	Area of validity	6
1.2	Target Group	6
1.3	Additional Information	6
1.4	Symbols Used	7
<b>2</b>	<b>Safety</b>	<b>8</b>
2.1	Appropriate Usage	8
2.2	Safety Instructions	9
2.3	Explanation of Symbols	9
2.3.1	Symbols on the Inverter	9
2.3.2	Symbols on the Type Label	10
<b>3</b>	<b>Unpacking.</b>	<b>11</b>
3.1	Packing List	11
3.2	Identifying the Inverter	12
<b>4</b>	<b>Installing the Device.</b>	<b>13</b>
4.1	Safety	13
4.2	Selecting the Mounting Location	14
4.3	Mounting the Inverter with Wall Mounting Bracket	15
<b>5</b>	<b>Electrical Connection</b>	<b>17</b>
5.1	Overview of the Connection Area	17
5.1.1	Exterior View	17
5.1.2	Interior View	18
5.2	Connection to the Public Grid (AC)	19
5.2.1	Conditions for the AC connection	19
5.2.2	Connecting to the Public Grid (AC)	21
5.3	Setting the Display Language	24

5.4	Connecting the Small Wind Turbine System (DC) . . . . .	25
5.4.1	Conditions for the DC connection . . . . .	25
5.4.2	Assembling the DC Plug Connectors. . . . .	26
5.4.3	Opening the DC Plug Connector . . . . .	28
5.4.4	Connecting the Small Wind Turbine System (DC). . . . .	29
5.5	Communication . . . . .	30
5.6	Setting the Grid Parameters and Country Parameters . . . . .	30
5.6.1	Setting the Installation Country . . . . .	30
5.6.2	Setting Off-Grid Operation . . . . .	31
5.7	Polynomial Characteristic Curve . . . . .	32
<b>6</b>	<b>Commissioning . . . . .</b>	<b>33</b>
6.1	Commissioning the Inverter . . . . .	33
6.2	Operating Modes of the Inverter . . . . .	34
<b>7</b>	<b>Opening and Closing . . . . .</b>	<b>35</b>
7.1	Safety . . . . .	35
7.2	Opening the Inverter. . . . .	36
7.3	Closing the Inverter. . . . .	37
<b>8</b>	<b>Maintenance and Cleaning . . . . .</b>	<b>38</b>
<b>9</b>	<b>Failure Search. . . . .</b>	<b>39</b>
9.1	Blink Codes. . . . .	39
9.2	Error Messages. . . . .	40
9.3	Red LED is glowing continuously. . . . .	44
9.3.1	Checking the Small Wind Turbine System for a Ground Fault . . . . .	44
9.3.2	Checking the Function of the Varistors . . . . .	45
<b>10</b>	<b>Decommissioning . . . . .</b>	<b>47</b>
10.1	Dismantling the Inverter. . . . .	47
10.2	Packing the Inverter. . . . .	48
10.3	Storing the Inverter . . . . .	48

- 10.4 Disposing of the Inverter . . . . . 48
- 11 Technical Data . . . . . 49**
- 11.1 Windy Boy 2500 (WB 2500) . . . . . 49
- 11.2 Windy Boy 3000 (WB 3000) . . . . . 53
- 12 Accessories . . . . . 57**
- 13 Contact . . . . . 58**

MWPS World

# 1 Notes on this Manual

This manual describes the assembly, installation, commissioning and maintenance of the following SMA inverters:

- Windy Boy 2500 (WB 2500)
- Windy Boy 3000 (WB 3000)

Store this manual where it can be accessed at all times.

## 1.1 Area of validity

This manual applies to all WB 2500 and WB 3000 device types with firmware version 2.87 and higher.

## 1.2 Target Group

This manual is for qualified personnel. The tasks described in this manual may be performed by qualified personnel only.





## 1.3 Additional Information

You will find further information on special topics such as designing a line circuit breaker or the description of the operating parameters in the download area at [www.SMA.de/en](http://www.SMA.de/en).

Refer to the user manual for detailed information on operating the inverter.

## 1.4 Symbols Used

The following types of safety precautions and general information are used in this manual:

	<b>DANGER!</b> DANGER indicates a hazardous situation which, if not avoided, will result in death or serious injury.
	<b>WARNING!</b> WARNING indicates a hazardous situation which, if not avoided, could result in death or serious injury.
	<b>CAUTION!</b> CAUTION indicates a hazardous situation which, if not avoided, could result in minor or moderate injury.
	<b>NOTICE!</b> NOTICE indicates a situation that can result in property damage, if not avoided.
	<b>Information</b> Information provides tips that are valuable for the optimal operation of the inverter.
<input checked="" type="checkbox"/>	This symbol indicates an outcome.

## 2 Safety

### 2.1 Appropriate Usage

The Windy Boy is a wind power inverter, which converts rectified current of a small wind turbine system into AC current and feeds this energy into the public grid, domestic grid or the Sunny Island system.

#### Principle of a small wind turbine system with Windy Boy

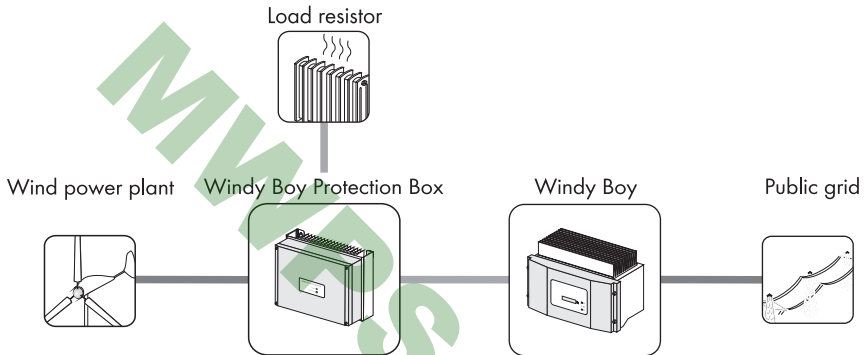

Furthermore, the Windy Boy can be used as an inverter for power conversion units based on the permanent magnet generators (hydro power systems, combined heat and power plants, diesel generator, etc.). The manufacturer of the small wind turbine system or the generators should have his system set up for operation with the Windy Boy (see also the Windy Boy planning guidelines in the download area at [www.SMA.de/en](http://www.SMA.de/en)).

When designing the system, ensure that the permitted operating range of all components is maintained at all times. Also use appropriate protective measures to make sure that the maximum permissible input voltage of the inverter is not exceeded. SMA Solar Technology AG offers you the corresponding components, such as the Windy Boy Protection Box (overvoltage protection for wind power inverters including the rectifier).

## 2.2 Safety Instructions





 <p><b>DANGER!</b> Danger to life due to high voltages in the inverter.</p>
<ul style="list-style-type: none"> <li>• All work on the inverter may be carried out by qualified personnel only.</li> </ul>

 <p><b>CAUTION!</b> Danger of burn injuries due to hot enclosure parts.</p>
<ul style="list-style-type: none"> <li>• Do not touch enclosure during operation.</li> <li>• Only touch the lid during operation.</li> </ul>











## 2.3 Explanation of Symbols

This section gives an explanation of all the symbols shown on the inverter and on the type label.

### 2.3.1 Symbols on the Inverter

Symbol	Explanation
	Operation Display. Shows the operating status of the inverter.
	Ground fault or varistor defective. There is either a ground fault in the system, or at least one of the varistors inside the inverter is defective.
	An error has occurred. Read the installation guide and the user manual to remedy the malfunction.
	Tap to switch on the display light and switch to the next message.

## 2.3.2 Symbols on the Type Label

Symbol	Explanation
	Beware of dangerous electrical voltage. The inverter operates at high voltages. All work on the inverter may be carried out by qualified personnel only.
	Beware of hot surface. The inverter can become hot during operation. Avoid contact during operation.
	Observe all documentation accompanying the inverter.
	The inverter must not be disposed of with the household waste. For further information on disposal, see section 10.4 "Disposing of the Inverter" (page 48).
	CE mark. The inverter complies with the requirements of the applicable EC guidelines.
	RAL quality mark for solar products. The inverter complies with the requirements of the German Institute for Quality Assurance and Labeling.
	The inverter has a transformer.
	Direct Current (DC)
	Alternating Current (AC)
	The inverter is protected against penetration by dust particles and water jets from any angle.

## 3 Unpacking

### 3.1 Packing List

Check the delivery for completeness and for any visible external damage. Contact your dealer if anything is damaged or missing.

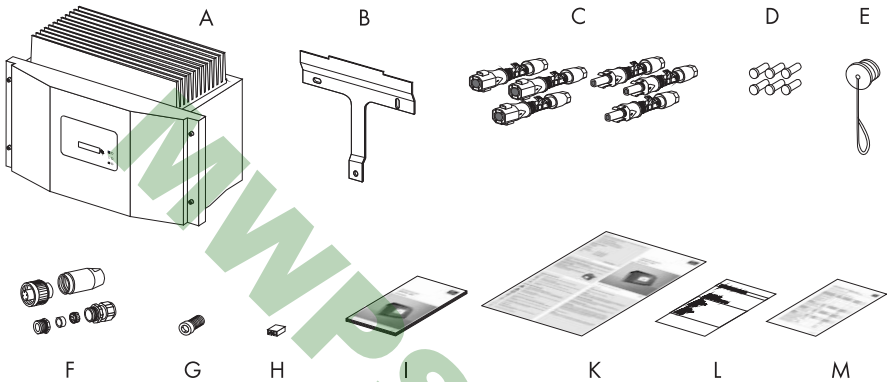

Object	Number	Description
A	1	Inverter
B	1	Wall mounting bracket
C	6	DC plug connectors (3 x positive / 3 x negative)
D	6	Sealing plugs for DC plug connectors
E	1	Protective cap for AC plug connector on inverter
F	1	AC connection socket: socket unit, threaded sleeve, pressure screw PG13.5, sealing ring PG13.5, fastening case PG13.5, cable gland PG16
G	1	M6x12 cylinder head screw
H	1	Jumper
I	1	Installation Guide
K	1	User Manual
L	1	Set of documents with explanations and certificates
C	1	Supplement with the factory settings of the inverter

## 3.2 Identifying the Inverter

You can identify the inverter by the type label. The type label is on the right side of the enclosure.

The serial number (Serial No.) and the type (Type / Model) of the product, as well as device-specific characteristics are specified on the type label.

MWPS World

## 4 Installing the Device

### 4.1 Safety

**DANGER!**

**Danger to life due to fire or explosion.**

Despite careful construction, electrical devices can cause fires.

- Do not mount the inverter on flammable construction materials.
- Do not install the inverter in areas where highly flammable materials are stored.
- Do not install inverters in areas with a risk of explosion.

**CAUTION!**

**Danger of burn injuries due to hot enclosure parts.**

- Mount the inverter in such a way that the enclosure cannot be touched inadvertently.

**CAUTION!**

**Risk of injury due to the heavy weight of the inverter!**

- Remember that the inverter weighs approx. 31 kg.

## 4.2 Selecting the Mounting Location

Consider the following points when selecting where to install:

- The installation method and location must be suitable for the inverter's weight and dimensions (see section 11 "Technical Data" (page 49)).
- Mount on a solid surface.
- It must be possible to access the installation location freely and safely at all times without the need for additional tools such as scaffolding or lifting platforms. Service actions are otherwise limited.

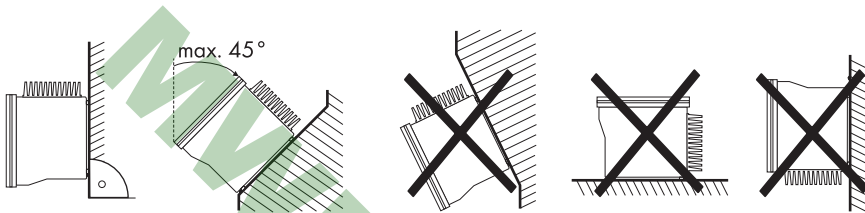

- Vertical installation or tilted backwards by max. 45°.
- Never mount the device with a forward tilt.
- Do not install horizontally.
- The connection area must point downwards.
- Install at eye level in order to allow the operating status to be read at all times.
- To ensure optimal operation, the ambient temperature should be below 40 °C.
- Do not expose the inverter to direct sunlight to avoid a power reduction due to excessive heating.
- In living areas, do not mount the unit on plasterboard walls or similar in order to avoid audible vibrations. The inverter can make noises when in use which may be perceived as a nuisance in a living area.
- Observe the minimum clearances to walls, other inverters or objects as shown in the diagram in order to guarantee sufficient heat dissipation.

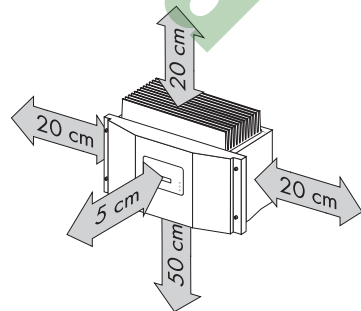

### 4.3 Mounting the Inverter with Wall Mounting Bracket



**CAUTION!**

**Risk of injury due to the heavy weight of the inverter!**

- Remember that the inverter weighs approx. 31 kg.
- When mounting the bracket, use fastening material suitable for the material.

1. Use the wall mounting bracket as a drilling template and mark the positions of the drill holes.

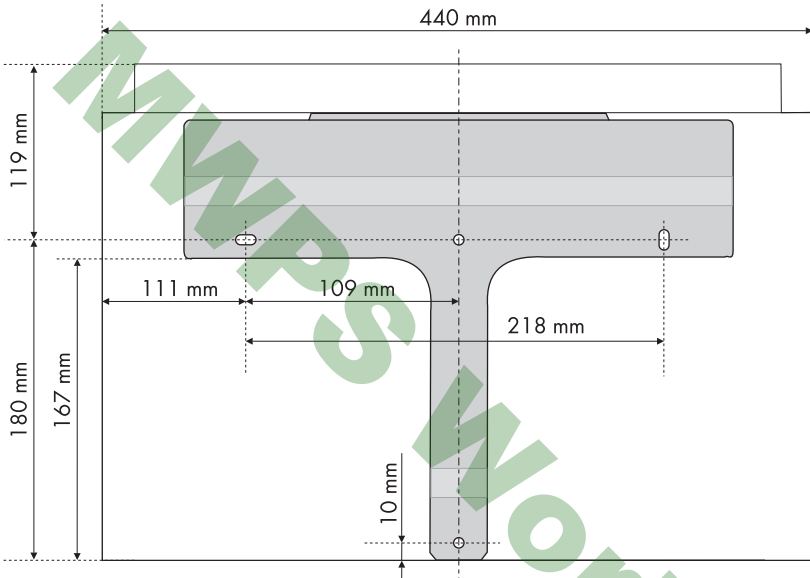

2. Attach the wall mounting bracket to the wall using appropriate screws and washers.

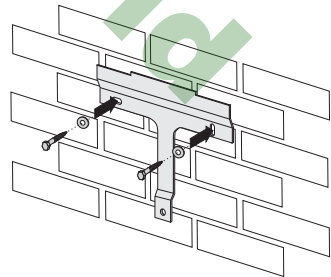

3. Use the upper mounting clips to fit the inverter in the wall mounting bracket so that it cannot be pushed out of the wall mounting bracket from the side.

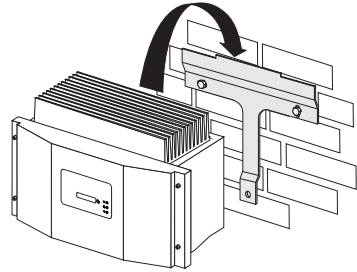

4. Use the provided M6x12 screws to fix the inverter and prevent it from being lifted out of place.

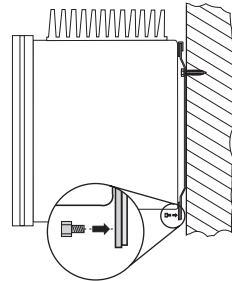

5. Check to ensure the inverter is firmly fastened.  
 The inverter is now mounted to the wall.

## 5 Electrical Connection

### 5.1 Overview of the Connection Area

#### 5.1.1 Exterior View

The following figure shows the assignment of the individual enclosure openings on the bottom of the inverter.

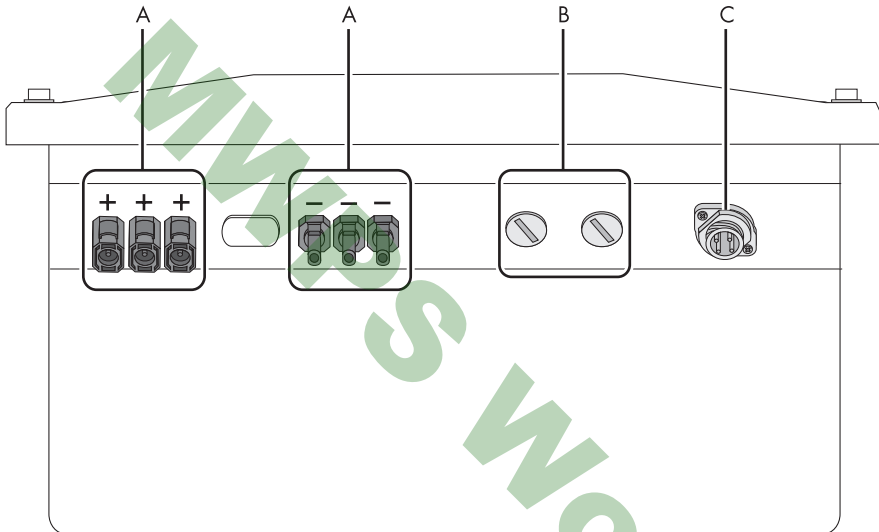

Object	Description
A	DC plug connectors for connecting the small wind turbine system
B	Enclosure opening with sealing plugs for communication
C	Plug for AC connection

### 5.1.2 Interior View

The following illustration shows the various components and connection areas of the open inverter.

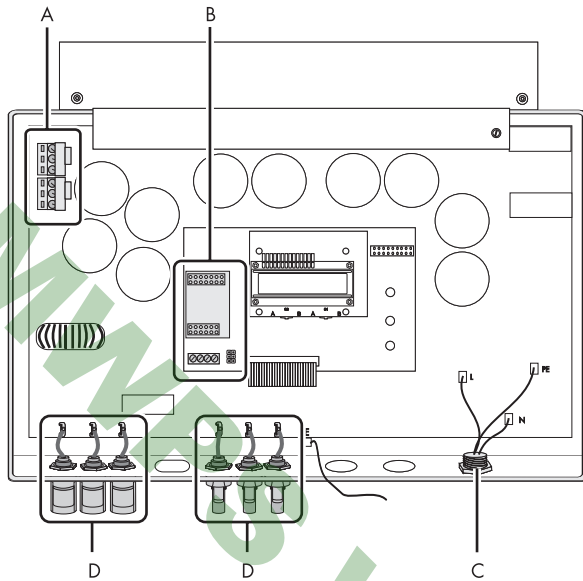

Object	Description
A	Varistors
B	Connection area and sockets for optional communication via RS485
C	Plug socket (AC)
D	DC plug connectors

## 5.2 Connection to the Public Grid (AC)

### 5.2.1 Conditions for the AC connection

Observe all connection conditions of the utility operator for connecting to the public grid!

#### Cable Sizing

The wire cross-sectional area should be dimensioned so output losses do not exceed 1 % at nominal power.

The maximum cable lengths relative to the conductor cross-section are shown in the following table.

Cross section of insulated conductor	Maximum wire length	
	WB 2500	WB 3000
1.5 mm <sup>2</sup>	9 m	-
2.5 mm <sup>2</sup>	15.5 m	12.5 m

The conductor cross-sectional area required in individual cases depends on the following factors:

- Ambient temperature
- Routing method
- UV resistance

#### Cable Requirements

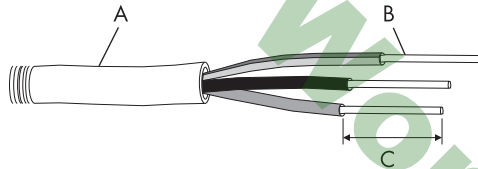

Object	Description	Value
A	External diameter	9 mm ... 17 mm
B	Conductor cross-section	Max. 2.5 mm <sup>2</sup>
C	Strip insulation	Approx. 4 mm

## Load Disconnection Unit

You must install a **separate** line circuit breaker for each inverter in order to ensure that the inverter can be securely disconnected under load. The maximum permissible rating is located in section 11 "Technical Data" (page 49).

Detailed information and examples for the rating of a line circuit breaker can be found in the Technical Information "Line Circuit Breaker" in the SMA Solar Technology AG download area at [www.SMA.de/en](http://www.SMA.de/en).



### DANGER!

#### Danger to life due to fire.

When more than one inverter is connected to the same line circuit breaker, the protective function of the line circuit breaker is no longer guaranteed. It can result in a cable fire or the destruction of the inverter.

- Never connect several inverters to the same line circuit breaker.
- Comply with the maximum permissible fuse protection of the inverter when selecting the circuit breaker.



### DANGER!

#### Risk of lethal electric shock.

When a generator (inverter) and a consumer are connected to the same line circuit breaker, the protective function of the line circuit breaker is no longer guaranteed. The current from the inverter and the grid can accumulate to overcurrent which is not detected by the line circuit breaker.

- Never connect loads between the inverter and the line circuit breaker without protection.
- Always protect loads separately.

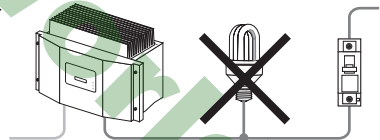

### NOTICE!

#### Damage to the inverter by using screw type fuse elements as a load disconnection unit!

A screw type fuse element, e.g. D system (Diazed) or D0 system (Neozed) is not a load disconnection device, and thus may **not** be used as a load disconnection unit. A screw type fuse element is only used as cable protection.

When disconnecting under load using a screw type fuse element, the inverter can be damaged.

- Use only a load disconnecting switch or a line circuit breaker as load disconnecting unit.

## 5.2.2 Connecting to the Public Grid (AC)

### Overview of the AC connection socket

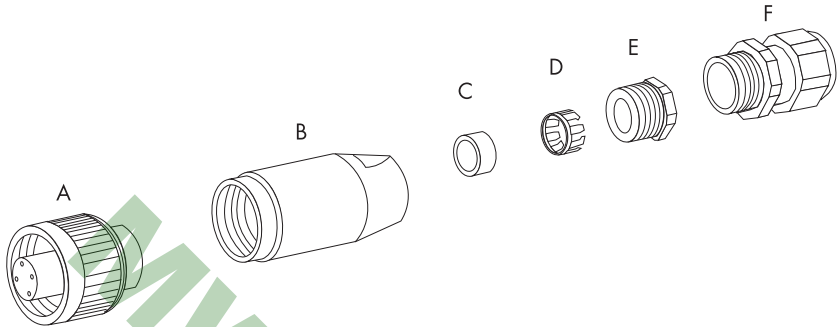

Object	Description
A	Socket element
B	Threaded sleeve
C	Sealing ring PG13.5
D	Fastening case PG13.5
E	Pressure screw for PG13.5 (for a cable diameter between 9 mm ... 13.5 mm)
F	Cable gland PG16 (for a cable diameter between 13.5 and 17 mm)

### Procedure

1. Choose an appropriate screw fitting for the AC cable.
2. Check that the grid voltage is within the admissible voltage range.

The exact operating range of the inverter is specified in the operating parameters. The corresponding document is available in the download area at [www.SMA.de/en](http://www.SMA.de/en) in the category "Technical Description" of the respective inverter.

3. Disconnect the line circuit breaker and secure against re-connection.
4. Strip approx. 30 mm from the AC cable.
5. Shorten L and N by 5 mm.

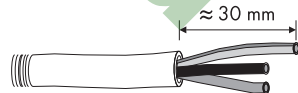

6. Strip 4 to 5 mm of insulation from the AC cable.
7. Lead the pressure screw and/or cable gland and threaded sleeve over the AC cable.

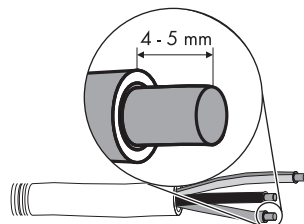

Size used	Procedure
<p><b>PG13.5</b></p>	<ul style="list-style-type: none"> <li>• Push the sealing ring into the fastening case.</li> <li>• Lead the pressure screw PG13.5 and the fastening case including the sealing ring over the AC cable.</li> <li>• Lead the threaded sleeve over the AC cable.</li> </ul>
<p><b>PG16</b></p>	<ul style="list-style-type: none"> <li>• Lead the cable gland PG16 over the AC cable.</li> <li>• Lead the threaded sleeve over the AC cable.</li> </ul>

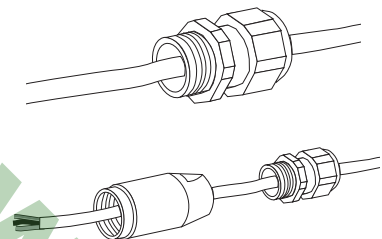
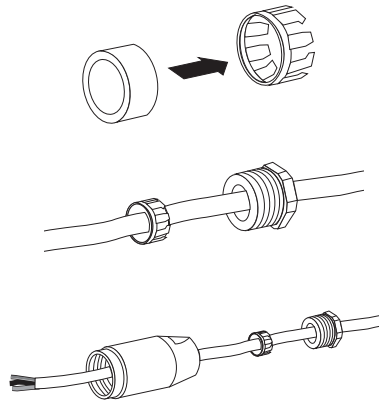

8. Insert the PE protective conductor (green-yellow) into the screw terminal with the earth sign on the socket element and tighten the screw.
9. Insert the neutral conductor N (blue) into the screw terminal 1 on the socket and tighten the screw.
10. Insert phase L (brown or black) into the screw terminal 2 on the socket element and tighten the screw.
11. Terminal 3 on the socket element remains unused.
12. Make sure the wires are securely connected.

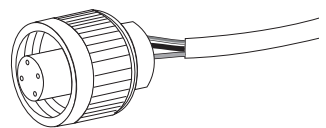
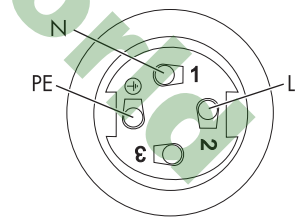

- Screw the threaded sleeve tightly onto the socket element.

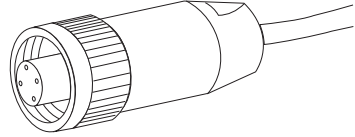

- Tighten the pressure screw or cable gland tightly onto the threaded sleeve.

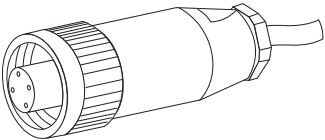
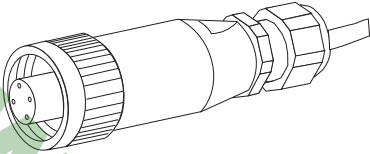
Size used	Procedure
PG13.5	 <p>The fastening case along with the sealing ring is pressed into the threaded sleeve and can no longer be seen.</p>
PG16	<ul style="list-style-type: none"> <li>Retighten the lock nut to the cable gland.</li> </ul> 

The AC connection socket has been screwed together.

- If the AC connection socket is not immediately connected to the inverter, close the AC plug on the inverter with the protective cap provided.
- Insert the AC connection socket into the AC socket on the inverter. Remove the protective cap beforehand as required.
- Turn the threaded ring of the AC connection socket tightly onto the AC socket on the inverter. The threaded ring serves to seal and relieve strain on the AC connection socket.

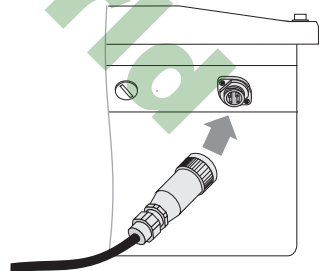

The AC cable is now connected to the inverter.

### 5.3 Setting the Display Language

You can set the language of the display using the switches on the underside of the display assemblies inside the inverter.

**Procedure**

1. Open the inverter as described in section 7.2 "Opening the Inverter" (page 36).
2. Set the switches for the required language, as shown below.

Language	Switch S2	Switch S1
German	B	B
English	B	A
French	A	B
Spanish	A	A

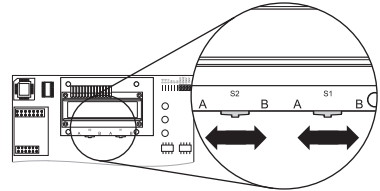

3. Close the inverter as described in section 7.3 "Closing the Inverter" (page 37).
- The display language is now set.

## 5.4 Connecting the Small Wind Turbine System (DC)

### 5.4.1 Conditions for the DC connection

- The connection cables of the small wind turbine system must be equipped with plug connectors. You will find the necessary DC plug connectors for the DC connection in the delivery.
- The following limiting values at the DC input of the inverter may not be exceeded:

Maximum input voltage	Maximum input current
600 V	12 A



#### **DANGER!**

**Risk of lethal electric shock or fire.**

The maximum possible input current is limited by the plug connectors used. If the plug connectors are overloaded, an electric arc may occur and there is a risk of fire.

- Ensure that the input current does not exceed the maximum flow current of the plug connectors used.



#### **NOTICE!**

**Destruction of the inverter by overvoltage.**

If the voltage of the small wind turbine system exceeds the maximum input voltage of the inverter, it can be destroyed by the overvoltage. All warranty claims become void.

- Install overvoltage protection, e.g. Windy Boy Protection Box, between the small wind turbine system and the inverter.

### 5.4.2 Assembling the DC Plug Connectors

The connection cables of the small wind turbine system must be equipped with the supplied DC plug connectors for connecting the inverter.

To assemble the DC plug connectors, proceed as follows: Make sure the plug connectors have the correct polarity. The DC plug connectors have the symbols "+" and " - ".

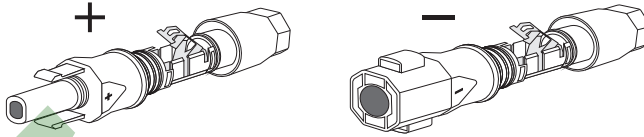

**Cable requirements:**

- Use a PV1-F cable.

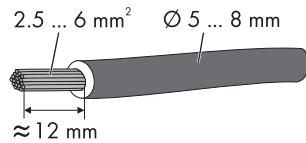

**Procedure**

1. Insert the stripped cable into the plug connector as far as it will go.
2. Press the clamping clip down until it audibly snaps into place.
3. Ensure the cable is correctly in place.

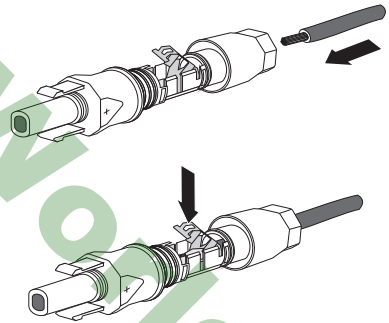

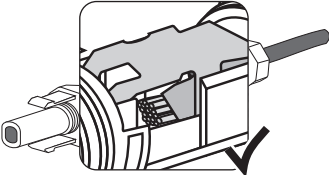
Result	Action
<p>☑ If the conductor is visible in the hollow cavity of the clamp, the cable is in the correct position.</p> 	<ul style="list-style-type: none"> <li>• Proceed to step 4.</li> </ul>

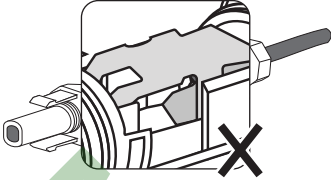
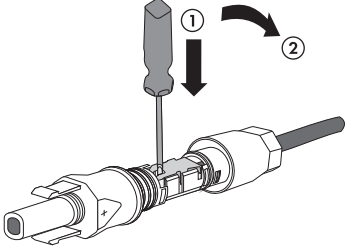
Result	Action
<p>☑ If the conductor is <b>not</b> visible in the hollow cavity of the clamp, the cable is not in the correct position.</p> 	<ul style="list-style-type: none"> <li>Loosen the clamping clip with the help of a screwdriver.</li> </ul>  <ul style="list-style-type: none"> <li>Remove the cable and start again from step 1.</li> </ul>

4. Push the threaded joint to the thread and screw into place.

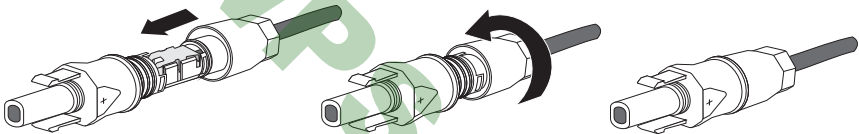

☑ The DC plug connectors are now assembled and can be connected to the inverter as described in section 5.4.4 "Connecting the Small Wind Turbine System (DC)" (page 29).

### 5.4.3 Opening the DC Plug Connector

1. Screw the threaded joint off.
2. To release the plug connector, slot a screw driver into the side catch mechanism and lever out.

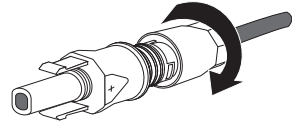

3. Carefully pull apart the DC plug connector.

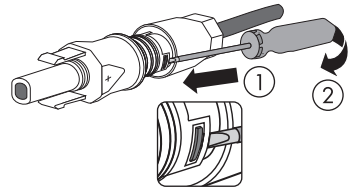

4. Loosen the clamping clip with the help of a screwdriver.

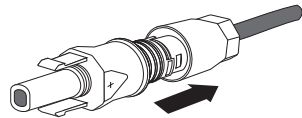

5. Remove cable.

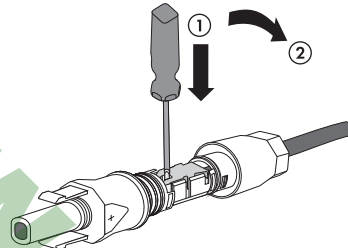

5. Remove cable.

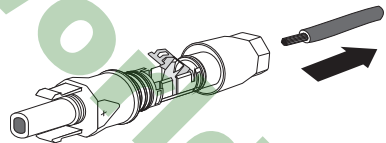

- The cable is removed from the DC plug connector.

## 5.4.4 Connecting the Small Wind Turbine System (DC)



### DANGER!

Danger to life due to high voltages in the inverter.

- Before connecting the small wind turbine system, ensure that the small wind turbine system is stopped.

1. Check the DC plug connectors for correct polarity and connect them to the inverter. To release the DC plug connectors, see section 7.2 "Opening the Inverter" (page 36).

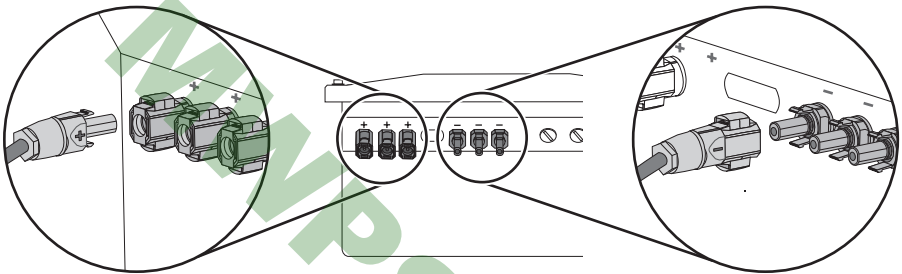

2. To create the sealing on the inverter, all the DC inputs that are not needed have to be closed as follows:
  - Insert the sealing plugs provided into the DC plug connectors that are not required. Do **not** insert the sealing plugs into the DC inputs on the inverter.
  - Insert the DC plug connectors with sealing plugs into the corresponding DC inputs on the inverter.

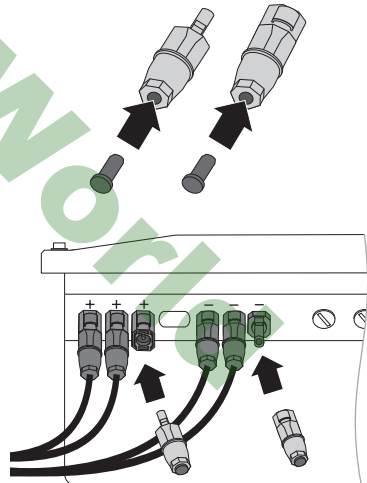

- The small wind turbine system is connected. You can now commission the inverter as described in section 6 "Commissioning" (page 33). The following connection options are optional.

## 5.5 Communication

The inverter is equipped with a slot for communication interfaces, so that it can communicate using special data acquisition devices (e.g. Sunny WebBox) or a PC with appropriate software.

See the communication interface manual for a detailed wiring diagram and a description of the mounting.

## 5.6 Setting the Grid Parameters and Country Parameters



### Changing grid-relevant parameters and country parameters

To change the grid-relevant parameters, you need a personal access code, the so-called SMA grid guard code. The application form for the personal access code can be found in the download area at [www.SMA.de/en](http://www.SMA.de/en) in the category "Certificate" of the respective inverter.

**Ensure** that you discuss the changes to these parameters with your utility operator.

A detailed description of the operating parameter for the inverter is available in the download area at [www.SMA.de/en](http://www.SMA.de/en) in the category "Technical Description" of the respective inverter.

### 5.6.1 Setting the Installation Country

Using the "Default" parameter you can set the installation country and/or the grid connection standard valid for the country via a communication device (e.g. Sunny WebBox) or a PC with appropriate software (e.g. Sunny Data Control or Sunny Explorer). This, however, is only required if the inverter was originally ordered for another country. You can see the standard to which the inverter was set upon delivery on the type label and the enclosed data sheet with the factory settings.

## 5.6.2 Setting Off-Grid Operation

To operate the inverter in a Sunny Island system, you must set the inverter via the "Default" parameter to off-grid ("OFF-Grid") operation.

You have several possibilities to set the inverter to off-grid operation:

- Setting via Sunny WebBox  
or
- Setting via Sunny Data Control or Sunny Explorer



### DANGER!

**Danger to life due to high voltages in the event of outage of the public grid.**

If you set the inverter to off-grid operation, it does not fulfill any country-specific standards and regulations. Therefore if there is an outage of the public grid there is a danger of back feed.

- **Never** operate the inverter directly on the public grid when set to off-grid operation.

## 5.7 Polynomial Characteristic Curve

The polynomial characteristic curve is a programmable power curve depending on the DC input voltage. By adapting the default polynomial characteristic curve to the small wind turbine system being used, you can optimize the energy output of the small wind turbine system.

To optimally adapt the polynomial characteristic curve of the inverter to the wind turbine system being used, you can change the following parameters on the PC with the "Windy Boy Setup Tool" ([www.SMA.de/en](http://www.SMA.de/en)):

- Vpv-Start
- UdcWindStart
- Wind\_a<sub>0</sub> ... Wind\_a<sub>3</sub>
- Pmax
- P-Wind-Ramp
- KP-Wind-Reg
- KI-Wind-Reg
- T-Stop

A description of the operating parameter is available in the download area at [www.SMA.de/en](http://www.SMA.de/en) in the category "Technical Description" of the respective inverter.

The inverter regulates its output power according to the generator voltage. The following illustration shows the function of a typical polynomial characteristic curve of a WB 2500/ WB 3000. Here, the fed-in AC power is shown according to the DC input voltage of the inverter.

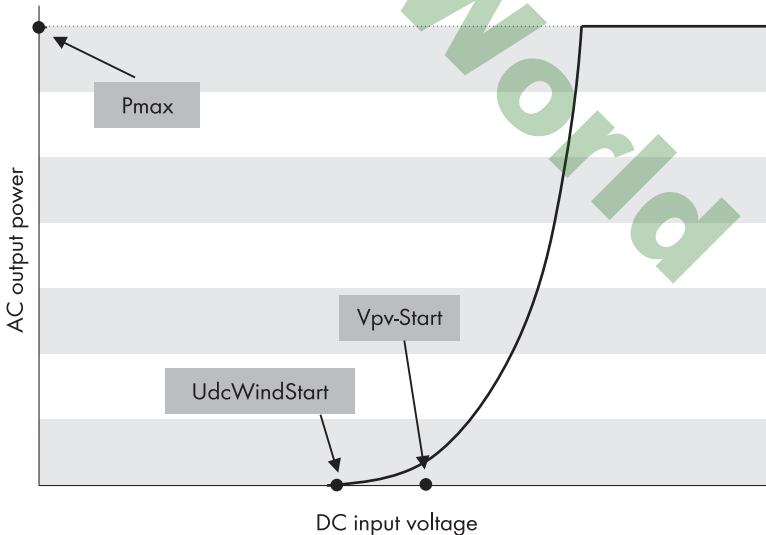

## 6 Commissioning

### 6.1 Commissioning the Inverter

1. Check the following requirements before commissioning:
  - Correct mounting and correct connection of the inverter.
  - The enclosure lid is securely closed.
  - The line circuit breaker is laid out correctly
  - Correct grounding of the small wind turbine system in accordance with the instructions of the manufacturer.
  - The rectifier and overvoltage protection (e.g. Windy Boy Protection Box) are installed between the small wind turbine system and the inverter.
  - DC inputs that are not needed are closed with the corresponding DC plug connectors and sealing plugs.
2. Commission the small wind turbine system in accordance with the instructions of the manufacturer.
  - Green LED glows: commissioning has been successful.
  - or**
  - Green LED flashes: network connection conditions have not yet been reached. Wait until the green LED lights up.
  - or**
  - The red or yellow LED is glowing or flashing: there has been an error. Proceed to step 3.

Object	Description
A	Green LED: Operation
B	Red LED: Ground fault or varistor defective
C	Yellow LED: Disturbance

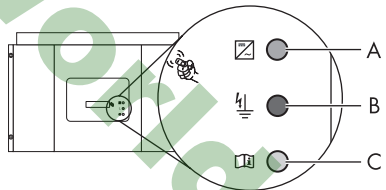

3. Read section 9 "Failure Search" (page 39) and if necessary, eliminate the disturbance.

## 6.2 Operating Modes of the Inverter

### Startup Procedure

If the inverter has enough voltage and power, the startup process is displayed by means of simultaneous lighting of the three LEDs on the inverter.

As soon as the DC input voltage defined in the parameter "Vpv-Start" is reached, the inverter starts a number of self-tests and measurement processes and synchronizes with the grid. This operating mode is indicated by the green LED flashing on the inverter.

When the tests are successfully completed and the DC input voltage is above "Vpv-Start" for the time configured in "T-Start," the inverter connects to the grid and the green LED lights up. The inverter then switches to characteristic curve operation, and regulates the input current according to the generator voltage.

### Characteristic Curve Operation

After the startup process, the inverter switches to characteristic curve operation, and regulates the output current according to the generator voltage.

The inverter then begins to put a load on the small wind turbine system, takes power from the small wind turbine system according to the present input voltage and then feeds it into the grid. The maximum output corresponds to the maximum AC power of the inverter. However, this can be set using the parameter "Pmax".

### Shutdown

If the wind strength is so low that the DC input voltage falls below an internally calculated value, then the inverter stops feeding power into the mains grid for the period defined in "T-Stop." When the DC input voltage increases again, the inverter switches back to characteristic curve operation.

If the DC input voltage remains below an internally calculated value for the time set in "T-Stop," the inverter will switch off.

If the DC input voltage is no longer sufficient to supply the on-board electronics with power, the inverter deactivates immediately.

## 7 Opening and Closing

### 7.1 Safety

**DANGER!**

Electric shock due to high voltage in the inverter. This can result in death or serious burns.

Pay attention to the following points before opening the inverter:

- Ensure that there are no hazardous voltages present on the AC side.
- Ensure that there are no hazardous currents or voltages present on the DC side.

**NOTICE!**

**Electrostatic discharges can damage the inverter.**

Internal components of the inverter can be irreparably damaged by electrostatic discharge.

- Ground yourself before touching a component.

## 7.2 Opening the Inverter

1. Stop the small wind turbine system and make sure that it will not restart.
2. Using a current probe, ensure that there is no current to all DC cables.
  - If current is detected, check the installation!

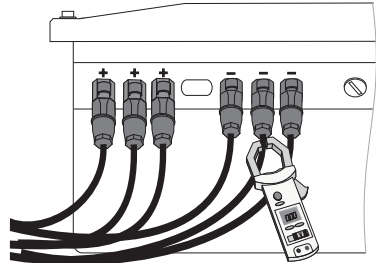

3. Release all DC plug connectors with the help of a screwdriver:
  - Insert a screwdriver into one of the side slits (1).
  - Lever the screwdriver upwards (2) and pull out the plug connector (3).

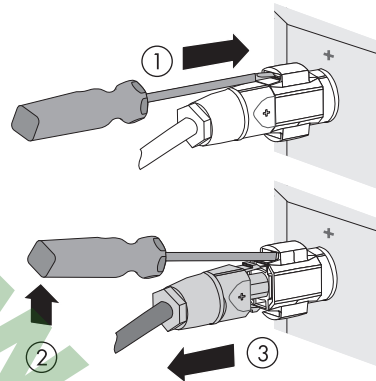

**DANGER!**

Danger to life due to high voltages in the inverter.

The capacitors in the inverter require 5 minutes to discharge.

- Wait 5 minutes before opening the inverter.

4. Remove all screws from the enclosure lid and pull the lid forward smoothly.

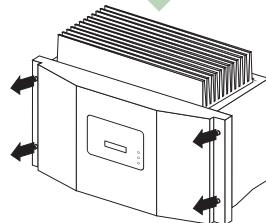

5. Remove the protective conductor (PE) connection from the lid by loosening the locking device of the PE connection on the lid.

- The inverter is open and there is no voltage present.

## 7.3 Closing the Inverter

1. Reconnect the protective conductor (PE) connection to the enclosure lid.
2. Secure the enclosure lid of the inverter by evenly tightening the 4 lid screws.

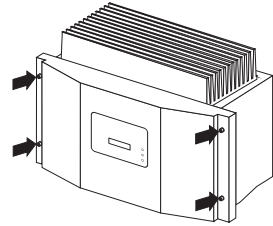

3. Check the DC plug connectors for correct polarity and connect them to the inverter. To release the DC plug connectors, see section 7.2 "Opening the Inverter" (page 36).

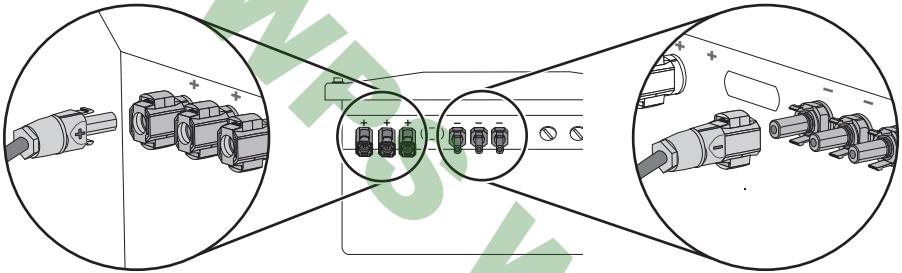

4. Close all the DC inputs that are not needed as described in section 5.4.4 "Connecting the Small Wind Turbine System (DC)" (page 29) in order to create the sealing on the inverter.
5. Switch on the line circuit breaker.
6. Commission the small wind turbine system in accordance with the instructions of the manufacturer.
7. Check whether the display and the LEDs indicate normal operating mode (see section 6 "Commissioning" (page 33)).

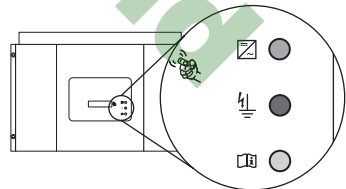

- The inverter is closed and in operation.

## 8 Maintenance and Cleaning

Check for proper inverter operation at regular intervals. Impurities such as dust or pollen can cause heat accumulation that can lead to yield losses. Also check the inverters and the cables for visible external damage. Undertake repairs if necessary.

MWPS World

## 9 Failure Search

If the inverter displays blink codes or error messages other than those described in the following section, contact the SMA service line.

You will find descriptions of the display messages during operation, status messages and measuring channels in the enclosed user manual.

Do not try to carry out repairs other than those described here. Instead, use the SMA Solar Technology AG 24-hour replacement service (the inverter will be ready for dispatch within 24 hours and sent to a forwarding agency) and repair service.

### 9.1 Blink Codes

Green	Red	Yellow	Status
Glow continuously	Is not glowing	Is not glowing	OK (feeding operation)
	Glow continuously	Is not glowing	Ground fault or varistor defective
		Glow continuously	OK (initialization)
Flashes quickly (3 x per second)	Is not glowing	Is not glowing	OK (stop)
	Glow continuously	Is not glowing	Ground fault or varistor defective
Flashes slowly (1 x per second)	Is not glowing	Is not glowing	OK (waiting, grid monitoring)
Briefly goes out (approx. 1 x per second)	Glow continuously	Is not glowing	Ground fault or varistor defective
	Is not glowing	Is not glowing	OK (derating)
Is not glowing	Is not glowing	Is not glowing	OK (disconnection)
		Glow / flashes	Disturbance
	Glow continuously	Is not glowing	Ground fault or varistor defective
Glow / flashes		Ground fault or varistor defective and disturbance	

## 9.2 Error Messages

When a disturbance occurs, the inverter generates a message that depends on the operating mode and the disturbance detected.

Message	Description and corrective measure
<b>!!PV-Overvoltage!! !DISCONNECT DC!</b>	<p>Overvoltage at DC input. The inverter can be destroyed by overvoltage.</p> <p><b>Corrective measures</b></p> <p>Disconnect the inverter from the grid immediately.</p> <ol style="list-style-type: none"> <li>1. Turn off the line circuit breaker.</li> <li>2. Stop the small wind turbine system.</li> <li>3. Disconnect all the DC plug connectors.</li> <li>4. Check DC voltage: <ul style="list-style-type: none"> <li>- If the DC voltage is above the maximum input voltage, check the system design.</li> <li>- If the DC voltage is under the maximum input voltage, reconnect the small wind turbine system to the inverter as described in section 5.4.4 "Connecting the Small Wind Turbine System (DC)" (page 29).</li> </ul> </li> </ol> <p>If the message occurs again, disconnect the inverter again and contact the SMA service line.</p>
<b>ACVtgRPro</b>	<p>The 10-minute-average grid voltage is no longer within the permissible range. This can have the following causes:</p> <ul style="list-style-type: none"> <li>• The grid voltage at the connection point is too high.</li> <li>• The grid impedance at the connection point is too high.</li> </ul> <p>The inverter disconnects to assure compliance with the voltage quality of the grid.</p> <p><b>Corrective measures</b></p> <p>Check the grid voltage at the point of connection of the inverter:</p> <ul style="list-style-type: none"> <li>• If, due to the local grid conditions, the grid voltage increases to 253 V or more, ask the utility operator whether the voltage at the feed-in point can be adjusted, or whether it would agree to an alteration of the limiting value ACVtgRPro for voltage quality monitoring.</li> <li>• If the grid voltage is continually within the acceptable range, and this error is still displayed, contact the SMA service line.</li> </ul>
<b>Bfr-Srr</b>	<p>Internal measurement comparison disturbance or hardware defect.</p> <p><b>Corrective measures</b></p> <ul style="list-style-type: none"> <li>• Contact the SMA service line if this disturbance occurs frequently.</li> </ul>

Message	Description and corrective measure
<b>EEPROM</b>	Transition disturbance during reading or writing of EEPROM data. <ul style="list-style-type: none"> <li>The disturbance has no effect on the performance of the inverter.</li> </ul>
<b>EEPROM dBh</b>	EEPROM Data is defective, the inverter has switched itself off because the loss of data has disabled important functions of the inverter. <p><b>Corrective measures</b></p> <ul style="list-style-type: none"> <li>Contact the SMA service line.</li> </ul>
<b>EeRestore</b>	One of the duplicate data sets in the EEPROM is defective and has been reconstructed without loss of data. <ul style="list-style-type: none"> <li>The error message only serves to inform you and has no effect on the performance of the inverter.</li> </ul>
<b>Fac-Bfr</b> <b>Fac-Srr</b> <b>FacFast</b>	The grid frequency is no longer within the permissible range ("Bfr" or "Srr" is an internal message of no relevance for the user). For safety reasons, the inverter disconnects itself from the grid. <p><b>Corrective measures</b></p> <ul style="list-style-type: none"> <li>Check the grid connection and contact the utility operator if necessary</li> <li>If the grid frequency is within the tolerance range, yet "Fac-Bfr," "Fac-Srr" or "FacFast" faults are still being displayed, contact the SMA service line.</li> </ul>
<b>Imax</b>	Overcurrent on the AC side. This indicator is displayed when the current at the AC grid is greater than specified. <p><b>Corrective measures</b></p> <ul style="list-style-type: none"> <li>Check the system design and grid conditions.</li> </ul>
<b>K1-Close</b> <b>K1-Open</b>	Fault during relay test. <p><b>Corrective measures</b></p> <ul style="list-style-type: none"> <li>Contact the SMA service line if this problem occurs frequently or several times in succession.</li> </ul>
<b>MSD-FAC</b> <b>MSD-UAC</b> <b>MSD-Timeout</b>	Internal measurement comparison disturbance or hardware defect. <p><b>Corrective measures</b></p> <ul style="list-style-type: none"> <li>Contact the SMA service line if this disturbance occurs frequently.</li> </ul>
<b>Offset</b>	The "Derating" operating condition is a normal operating condition that occurs prior to grid monitoring. If "offset" is displayed as an error, then there is a disturbance in the data logging. <p><b>Corrective measures</b></p> <ul style="list-style-type: none"> <li>Contact the SMA service line if this disturbance occurs frequently.</li> </ul>

Message	Description and corrective measure
<b>Riso</b>	<p>The electrical insulation between the small wind turbine system and ground is faulty. The resistance between the DC plus and/or DC minus connection and ground is outside the defined limit range.</p> <p><b>Corrective measures</b></p> <ul style="list-style-type: none"> <li>• Check the insulation of the system.</li> <li>• Check the system for ground faults as described in section 9.3.1 "Checking the Small Wind Turbine System for a Ground Fault" (page 44).</li> </ul>
<b>ROM</b>	<p>The inverter's firmware is faulty.</p> <p><b>Corrective measures</b></p> <ul style="list-style-type: none"> <li>• Contact the SMA service line if this disturbance occurs frequently.</li> </ul>
<b>Shut-Down</b>	<p>Temporary inverter fault.</p> <p><b>Corrective measures</b></p> <ul style="list-style-type: none"> <li>• Contact the SMA service line.</li> </ul>
<b>Vac-Bfr</b> <b>Vac-Srr</b>	<p>The grid voltage is no longer within the permissible range ("Bfr" or "Srr" is an internal message of no relevance for the user). This disturbance can be caused by any of the following conditions:</p> <ul style="list-style-type: none"> <li>• Grid disconnected (line circuit breaker, fuse),</li> <li>• AC cable is broken or</li> <li>• AC cable is high-resistance.</li> </ul> <p>For safety reasons, the inverter disconnects itself from the grid.</p> <p><b>Corrective measures</b></p> <ul style="list-style-type: none"> <li>• Check the grid current and the grid connection on the inverter.</li> <li>• If the grid voltage lies outside the acceptable range because of local grid conditions, ask the utility provider if the voltage can be adjusted at the feed-in point or if it would agree to changes in the values of the monitored operational limits (operating parameters: Uac-Min and Uac-Max).</li> <li>• If the grid frequency is within the tolerable range, yet "Uac-Bfr," or "Uac-Srr" faults are still being displayed, contact the SMA service line.</li> </ul>

Message	Description and corrective measure
VpvMax	<p>Overvoltage at DC input. The inverter can be destroyed by overvoltage.</p>
	<p><b>Corrective measures</b></p> <p>Disconnect the inverter from the grid immediately.</p> <ol style="list-style-type: none"> <li>1. Turn off the line circuit breaker.</li> <li>2. Stop the small wind turbine system.</li> <li>3. Disconnect all the DC plug connectors.</li> <li>4. Check DC voltage: <ul style="list-style-type: none"> <li>- If the DC voltage is above the maximum input voltage, check the system design.</li> <li>- If the DC voltage is under the maximum input voltage, reconnect the small wind turbine system to the inverter as described in section 5.4.4 "Connecting the Small Wind Turbine System (DC)" (page 29).</li> </ul> </li> </ol> <p>If the message occurs again, disconnect the inverter again and contact the SMA service line.</p>
<p><b>Watchdog</b> <b>Watchdog-Srr</b></p>	<p>Internal program run fault.</p> <p><b>Corrective measures</b></p> <ul style="list-style-type: none"> <li>• Contact the SMA service line if this disturbance occurs frequently.</li> </ul>

### 9.3 Red LED is glowing continuously

Should the red LED on the inverter glow continuously during operation, either there has been a ground fault in the system or at least one of the varistors inside the inverter is defective.

In intentionally grounded systems, the red LED has been lit up since the commissioning of the inverter. However, this has no impact on the functioning of the inverter. Before you check the small wind turbine system for a ground fault, make sure an intentional connection to the ground has been carried out.

With intentionally grounded small wind turbine systems, check occasionally that the varistors inside the inverter function correctly, since a fault with the varistors can no longer be displayed.

#### 9.3.1 Checking the Small Wind Turbine System for a Ground Fault

	<p><b>DANGER!</b>                  Electric shock resulting from contact with current-carrying parts. Death or serious burns.</p>
<ul style="list-style-type: none"> <li>Do not touch the small wind turbine system</li> <li>Only touch the cables of the small wind turbine system on their insulation.</li> <li>Do not touch PE.</li> </ul>	

1. Disconnect the inverter from both the DC and AC connections as described in section 7.2 "Opening the Inverter" (page 36).
2. Measure the voltages between the positive pole of the DC cables and the ground potential.
3. Measure the voltages between the negative pole of the DC cables and the ground potential.

Result	Action
<p><b>A voltage</b> is measurable for one of the two measurements.</p>	<p>There is a ground fault in the system.</p> <ul style="list-style-type: none"> <li>Correct the ground fault and reconnect the small wind turbine system to the inverter as described in section 5.4.4 "Connecting the Small Wind Turbine System (DC)" (page 29).</li> </ul>
<p><b>No voltage</b> can be measured.</p>	<p>It is likely that one of the thermally monitored varistors is defective.</p> <ul style="list-style-type: none"> <li>Check the function of the varistors as described in section 9.3.2 "Checking the Function of the Varistors" (page 45).</li> </ul>

- The check for ground faults in the system is completed.

### 9.3.2 Checking the Function of the Varistors

Varistors are wear parts. Their functional efficiency diminishes with age or following repeated responses as a result of overvoltages. It is therefore possible that one of the thermally monitored varistors has lost its protective function.



#### Position of Varistors

The position of the varistors is to be determined with the help of the diagram below. Observe the following allocation of the terminals:

- Terminal A: outer terminal (varistor connection **with loop** [crimp])
- Terminal B: middle terminal
- Terminal C: outer terminal (varistor connection **without loop** [crimp])

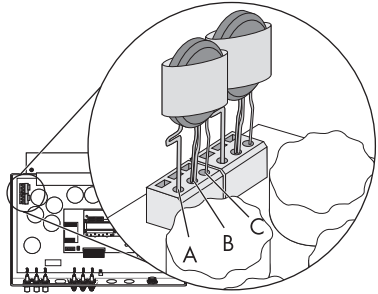

You can check the functionality of the varistors in the following manner:

1. Open the inverter as described in section 7.2 "Opening the Inverter" (page 36).
2. Use a Multimeter to ensure that both varistors in the installed state have a conducting connection between connectors B and C.

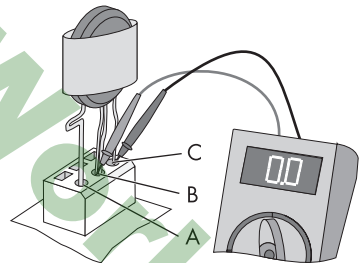

Result	Action
<input checked="" type="checkbox"/> There is a <b>conducting</b> connection.	There is probably a different fault in the inverter. <ol style="list-style-type: none"> <li>1. Close the inverter as described in section 7.3 "Closing the Inverter" (page 37).</li> <li>2. Contact the SMA service line.</li> </ol>

Result	Action
<p><input checked="" type="checkbox"/> There is <b>no conducting</b> connection.</p>	<p>The respective varistor is defective and must be replaced.</p> <p>Varistor failure is generally due to influences that affect all varistors similarly (temperature, age, induced overvoltage). SMA Solar Technology AG recommends that you replace both varistors.</p> <p>The varistors are specially manufactured for use in the inverter and are not commercially available. You must order replacement varistors directly from SMA Solar Technology AG (see section 12 "Accessories" (page 57)).</p> <ul style="list-style-type: none"> <li>To replace the varistors, proceed to step 3.</li> </ul>



**NOTICE!**

**Destruction of the inverter by overvoltage.**

- Procure replacement varistors as soon as possible and replace the defective ones immediately.
- For systems with a high risk of overvoltage, do **not** operate inverters using faulty varistors or no varistors at all.

3. Insert an insertion tool into the openings of the terminal contacts (1).

This releases the terminals.

If you do not receive an insertion tool for operating the clamps with your replacement varistors, please contact SMA Solar Technology AG. As an alternative, the terminal contacts can be operated using a 3.5 mm wide screwdriver.

4. Remove the varistor (2).

5. Insert new varistor (3).

The pole with the small loop (crimp) must be fitted to terminal A (3) when remounting.

6. Close the inverter as described in section 7.3 "Closing the Inverter" (page 37).

The check and replacement of the varistors is completed.

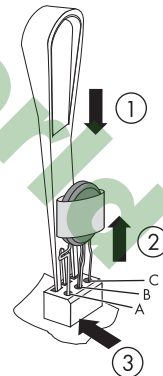

## 10 Decommissioning

### 10.1 Dismantling the Inverter

1. Open the inverter as described in section 7.2 "Opening the Inverter" (page 36).
2. Remove all cables from the inverter.
3. Close the inverter with the 4 screws.
4. Loosen the lower screw between the inverter and wall mounting bracket.

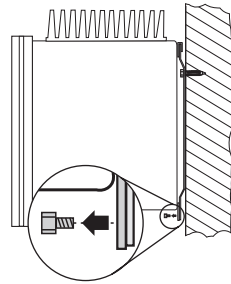

5. Remove the inverter upwards from the wall mounting bracket.

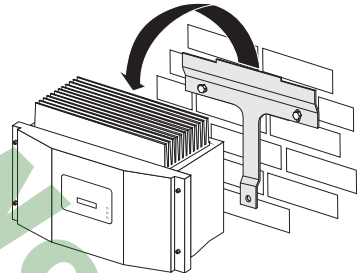

- The inverter is dismantled.

## 10.2 Packing the Inverter

If possible, always pack the inverter in its original packaging. If it is no longer available, you can also use an equivalent box. The box must be capable of being closed completely and made to support both the weight and the size of the inverter.

## 10.3 Storing the Inverter

Store the inverter in a dry place where ambient temperatures are always between  $-25\text{ °C}$  and  $+60\text{ °C}$ .

## 10.4 Disposing of the Inverter

Dispose of the inverter at the end of its service life in accordance with the disposal regulations for electronic waste which apply at the installation site at that time. Alternatively, send it back to SMA Solar Technology AG with shipping paid by sender, and labeled "ZUR ENTSORGUNG" ("FOR DISPOSAL") (see section 13 "Contact" (page 58))

WPS World

# 11 Technical Data

## 11.1 Windy Boy 2500 (WB 2500)

### DC Input

Turbine control		Polynomial characteristic curve
Nominal power	$P_{DC, nom}$	2,480 W
Maximum power	$P_{DC, max}$	2,700 W
Recommended generator power at 2,500 full-load hours per year	$P_{DC, 2500}$	2,000 W
Recommended generator power at 5,000 full-load hours per year	$P_{DC, 5000}$	1,800 W
Minimum power for feeding operation	$P_{DC, min}$	20 W
Nominal operating voltage	$U_{DC, nom}$	300 V
Maximum voltage at $U_{AC} = 230$ V	$U_{DC, max}$	600 V
Voltage range at $U_{AC} = 230$ V		224 V ... 600 V
Minimum adjustable open circuit voltage for grid synchronization	Vpv-Start	250 V
Voltage ripple	UPP	< 10 %
Nominal input current	$I_{DC, nom}$	8.3 A
Overall maximum input current	$I_{DC, max}$	12 A
Number of inputs		3
Maximum current per input		12 A

## AC Output

Nominal power	$P_{AC, nom}$	2,300 W
Maximum power	$P_{AC, max}$	2,500 W
Nominal current	$I_{AC, nom}$	10 A
Maximum output current	$I_{AC max}$	12.5 A
Maximum permissible rating		16 A
Grid current THD at $K_{Ugrid} < 2\%$ and $P_{AC} > 0.5 P_{nom}$	$K_{IAC}$	$< 4\%$
Nominal voltage	$U_{AC, nom}$	230 V
Grid voltage range		220 V ... 240 V
Minimum grid voltage	$U_{AC, min}$	180 V
Maximum grid voltage	$U_{AC, max}$	260 V
Nominal frequency (self-adjusting)	$f_{AC}$	50 Hz / 60 Hz
Operating range, grid frequency		$\pm 4.5$ Hz
Power factor at $P_{ACnom}$	$\cos \varphi$	1
Overvoltage category		III
AC Connection		AC connection socket
Maximum cable diameter		17 mm
Cross section of insulated conductor		2.5 mm <sup>2</sup>

## Protective Device

AC short-circuit protection	Current control
Islanding detection	Yes
Galvanically isolated	Yes, LF transformer
All-pole disconnection unit on the AC side	Independent disconnection device: SMA Grid Guard 2
All-pole disconnection unit on the DC side	DC plug system SUNCLIX
DC reverse polarity protection	Short circuit diode
DC overvoltage protection (Windy Boy Protection Box)	optional

## Mechanical Data

Width x height x depth	440 mm x 299 mm x 214 mm
Weight	28.1 kg

## Climatic Conditions

Operating temperature range	- 25 °C ... +60 °C
Relative air humidity (admissible)	0 % ... 100 %
Maximum operating altitude above mean sea level	2,000 m

## General Data

Protection rating *	IP65
Protection class	I
Noise emission (typical)	≤ 33 dB(A)

\* according to DIN EN 60529

## Features

Topology	Low frequency transformer
Cooling concept	Convection

## Internal Consumption

Internal consumption in operation	< 7 W
Internal consumption in standby	0.25 W

**Efficiency**

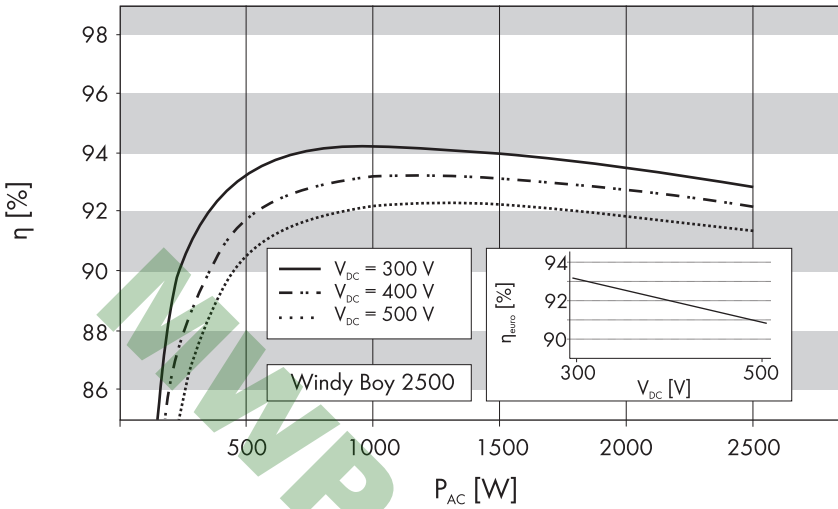

Peak efficiency	$\eta_{max.}$	94.1 %
Euro ETA	$\eta_{euro}$	93.2 %

## 11.2 Windy Boy 3000 (WB 3000)

### DC input

Turbine control		Polynomial characteristic curve
Nominal power	$P_{DC, nom}$	2,925 W
Maximum power	$P_{DC, max}$	3,200 W
Recommended generator power at 2,500 full-load hours per year	$P_{DC, 2500}$	2,400 W
Recommended generator power at 5,000 full-load hours per year	$P_{DC, 5000}$	2,100 W
Minimum power for feeding operation	$P_{DC, min}$	20 W
Nominal operating voltage	$U_{DC, nom}$	350 V
Maximum voltage at $U_{AC} = 230$ V	$U_{DC, max}$	600 V
Voltage range at $U_{AC} = 230$ V		268 V ... 600 V
Minimum adjustable open circuit voltage for grid synchronization	$V_{pv-Start}$	290 V
Voltage ripple	UPP	< 10 %
Nominal input current	$I_{DC, nom}$	8.4 A
Overall maximum input current	$I_{DC, max}$	12 A
Number of inputs		3
Maximum current per input		12 A

## AC Output

Nominal power	$P_{AC, nom}$	2,750 W
Maximum power	$P_{AC, max}$	3,000 W
Nominal current	$I_{AC, nom}$	12 A
Maximum output current	$I_{AC max}$	15 A
Maximum permissible rating		16 A
Grid current THD at $K_{Ugrid} < 2\%$ and $P_{AC} > 0.5 P_{nom}$	$K_{IAC}$	< 4 %
Nominal voltage	$U_{AC, nom}$	230 V
Grid voltage range		220 V ... 240 V
Minimum grid voltage	$U_{AC, min}$	180 V
Maximum grid voltage	$U_{AC, max}$	260 V
Nominal frequency (self-adjusting)	$f_{AC}$	50 Hz / 60 Hz
Operating range, grid frequency		$\pm 4.5$ Hz
Power factor at $P_{ACnom}$	$\cos \varphi$	1
Overvoltage category		III
AC Connection		AC connection socket
Maximum cable diameter		17 mm
Cross section of insulated conductor		2.5 mm <sup>2</sup>

## Protective Device

AC short-circuit protection	Current control
Islanding detection	Yes
Galvanically isolated	Yes, LF transformer
All-pole disconnection unit on the AC side	Independent disconnection device: SMA Grid Guard 2
All-pole disconnection unit on the DC side	DC plug system SUNCLIX
DC reverse polarity protection	Short circuit diode
DC overvoltage protection (Windy Boy Protection Box)	optional

## Mechanical Data

Width x height x depth	440 mm x 299 mm x 214 mm
Weight	31.3 kg

## Climatic Conditions

Operating temperature range	- 25 °C ... +60 °C
Relative air humidity (admissible)	0 % ... 100 %
Maximum operating altitude above mean sea level	2,000 m

## General Data

Protection rating *	IP65
Protection class	I
Noise emission (typical)	≤ 30 dB(A)

\* according to DIN EN 60529

## Features

Topology	Low frequency transformer
Cooling concept	Convection

## Internal Consumption

Internal consumption in operation	< 7 W
Internal consumption in standby	0.25 W

**Efficiency**

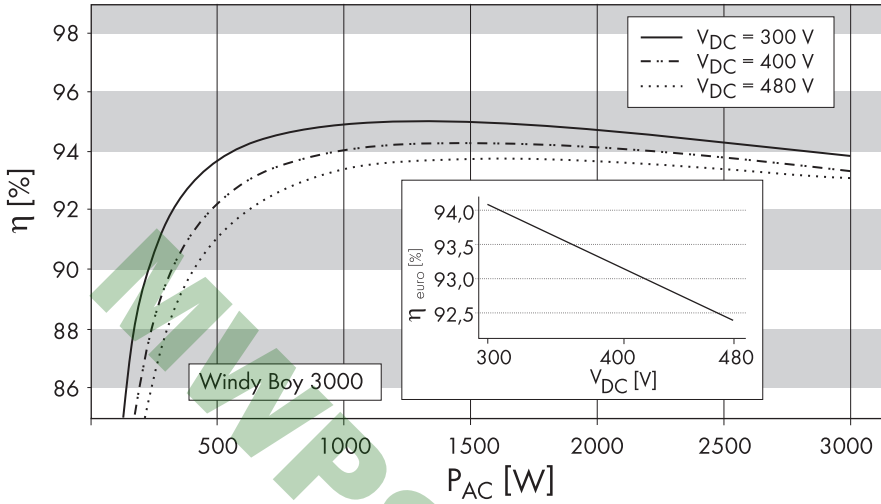

Peak efficiency	$\eta_{max.}$	95 %
Euro ETA	$\eta_{euro}$	93.6 %

## 12 Accessories

You will find the corresponding accessories and replacement parts for your inverter in the following overview. If required, you can order these from SMA Solar Technology AG or your dealer.

<b>Description</b>	<b>Brief description</b>	<b>SMA order number</b>
Windy Boy Protection Box	Rectifiers and overvoltage protection for small wind turbine systems with Windy Boy	WBP-Box 600
Replacement varistors	Set of thermally monitored varistors (2) including insertion tool	SB-TV 4
Installation tool for varistors	Tool for installing the varistors	SB-TVWZ
RS485 upgrade set	RS485 interface	485PB-NR
Bluetooth® Wireless Technology upgrade kit	Bluetooth interface	BTPBINV-NR
SUNCLIX DC plug connectors	Field plug for conductor cross sections of 2.5 mm <sup>2</sup> ... 6 mm <sup>2</sup>	SUNCLIX-FC6-SET

## 13 Contact

If you have technical problems concerning our inverters, contact the SMA Serviceline. We require the following information in order to provide you with the necessary assistance:

- Inverter type
- Inverter serial number
- Type of connected small wind turbine system
- Optional equipment, e.g. communication devices
- Blink code or display of inverter

MWPS World

### **SMA Solar Technology AG**

Sonnenallee 1  
34266 Niestetal, Germany  
[www.SMA.de](http://www.SMA.de)

### **SMA Serviceline**

Inverters: +49 561 9522 1499  
Communication: +49 561 9522 2499  
Fax: +49 561 9522 4699  
E-Mail: [Serviceline@SMA.de](mailto:Serviceline@SMA.de)

The information contained in this document is the property of SMA Solar Technology AG. Publishing its content, either partially or in full, requires the written permission of SMA Solar Technology AG. Any internal company copying of the document for the purposes of evaluating the product or its correct implementation is allowed and does not require permission.

## Exclusion of liability

The general terms and conditions of delivery of SMA Solar Technology AG shall apply.

The content of these documents is continually checked and amended, where necessary. However, discrepancies cannot be excluded. No guarantee is made for the completeness of these documents. The latest version is available online at [www.SMA.de](http://www.SMA.de) or from the usual sales channels.

Guarantee or liability claims for damages of any kind are excluded if they are caused by one or more of the following:

- Damages during transportation
- Improper or inappropriate use of the product
- Operating the product in an unintended environment
- Operating the product whilst ignoring relevant, statutory safety regulations in the deployment location
- Ignoring safety warnings and instructions contained in all documents relevant to the product
- Operating the product under incorrect safety or protection conditions
- Altering the product or supplied software without authority
- The product malfunctions due to operating attached or neighboring devices beyond statutory limit values
- In case of unforeseen calamity or force majeure

The use of supplied software produced by SMA Solar Technology AG is subject to the following conditions:

- SMA Solar Technology AG rejects any liability for direct or indirect damages arising from the use of software developed by SMA Solar Technology AG. This also applies to the provision or non-provision of support activities.
- Supplied software not developed by SMA Solar Technology AG is subject to the respective licensing and liability agreements of the manufacturer.

## SMA Factory Warranty

The current guarantee conditions come enclosed with your device. These are also available online at [www.SMA.de](http://www.SMA.de) and can be downloaded or are available on paper from the usual sales channels if required.

## Trademarks

All trademarks are recognized even if these are not marked separately. Missing designations do not mean that a product or brand is not a registered trademark.

The *Bluetooth*<sup>®</sup> word mark and logos are registered trademarks owned by Bluetooth SIG, Inc. and any use of such marks by SMA Solar Technology is under license.

### SMA Solar Technology AG

Sonnenallee 1

34266 Niestetal

Germany

Tel. +49 561 9522-0

Fax +49 561 9522-100

[www.SMA.de](http://www.SMA.de)

E-Mail: [info@SMA.de](mailto:info@SMA.de)

© 2004 to 2010 SMA Solar Technology AG. All rights reserved

SMA Solar Technology AG

[www.SMA.de](http://www.SMA.de)

