

The logo features a stylized blue leaf or flame shape above the word "PROVEN" in a blue serif font. Below "PROVEN", the word "ENERGY" is written in a green sans-serif font, with each letter spaced out.

PROVEN
ENERGY

WT6000
TM1500/TM900
MANUAL
BATTERY CHARGING SYSTEM

Proven Energy Ltd
Wardhead Park, Stewarton, Ayrshire, KA3 5LH, Scotland
Tel: +44 (0) 1560 485 570 Fax: +44 (0) 1560 485 580
E-mail: info@provenenergy.com Web: www.provenenergy.com



Congratulations on purchasing a Proven Energy System - the power of the wind is yours! Please fill in the following short questionnaire - this will help us to improve both our products and the information that we supply to our customers on operation, maintenance and installation.

NEW OWNER QUESTIONNAIRE FOR PROVEN ENERGY PRODUCTS	
Delivery	
Did your order arrive promptly? If not, give details.	
Was the order in good condition when it arrived? If not give details	
Installation	
What experience did the installer have of a) wind energy b) PV solar c) electrical wiring d) inverters e) batteries	a) b) c) d) e)
Were the Proven Installation Manuals helpful? If not, what would you like to see added.	
How long did the installation take (man-days)? How many people?	
What was the most difficult bit of the installation process?	
Performance	
How has the wind turbine performed since installation	
What % availability is estimated for a) the wind turbine b) the complete system?	a) b)
Maintenance	
Has the first (3 month) service been performed on the turbine? Give details of any work carried out.	
After Sales Care	
You have been put on the mailing list to receive details of new Proven Products and Proven Newsletters. What further support would you like?	

Thank you for your time in completing this form.

If you have further comments please send them on an attached sheet.

Please return to Fax No. + 44 (0) 1560 485 580 or mail it to -

Proven Energy Ltd, Wardhead Park, Stewarton, Ayrshire, KA3 5LH Scotland, UK

Email: info@provenenergy.com Web: www.provenenergy.com



WT6000 MANUAL

SYSTEM SPECIFICATION

Proven WT6000 6kW Wind Turbine

Proven TM900/TM1500, 9m/15m Un-Guyed Mast

Rotor Speed Control

Above 12m/s (25mph) the blade twist to limit the power in response to high rpm.

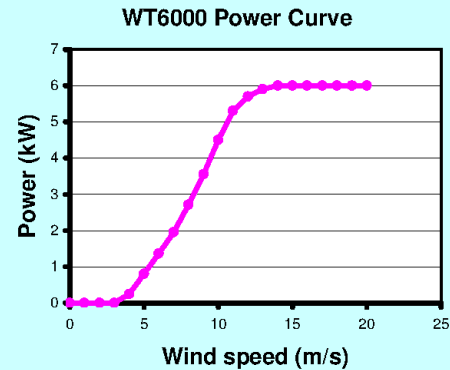

High Build Quality

All Components are hot-dipped galvanised steel, stainless steel or plastic. All bearings are triple sealed.

Performance	
Cut - in Wind Speed	2.5 metres/second (5.6 mph)
Cut - out Wind Speed	>70 metres/second (>155 mph)
Rated Wind Speed	12 metres/second (26 mph)
Rotor	
Type	Downwind, Self - Regulating
Number of Blades	3, Flexible
Blade Material	Glassthermoplastic Composite
Rotor Diameter	5.5 metres
Rated RPM	200
Rotor Thrust (kN)	10
Generator	
Type	Brushless, Direct Drive permanent Magnet (No gear-box, zero maintenance)
Output	Grid connect (230Vac 50Hz or 240Vac 60Hz), Battery Charging (48V DC), Direct Heating (240Vac)
Rated Power	6000 watts
Annual Output	6,000 - 12,000 kWh depending on site

Low Speed Equals Durability

Low rotor speed (half of the speed of comparable machines) ensures extended durability of blades and bearings. It also means that Proven WTs are the quietest in the world!

Mast	
Type	Tapered, Hinged, Self Supporting
Hub Height	9m or 15m
Foundation	2.5x2.5x1m ³ or 3x3x1.2m ³ Concrete
Noise	
45dB	At 5m/s
65dB	At 20m/s
70-80dB	Car 15m away speeding at approx 40mph (18m/s)
Weight	
WT6000	600 kg
TM900	360 kg
TM1500	656 kg

Sample of Commercial Customers
 British Telecom/Scottish Youth Hostel Association/Saudi Aramco/Irish Lighthouse Authority/Welsh Water/British Rail/Shell Exploration/T-mobile/Orange

Proven ECM6001/ECM6002

48V Wind Turbine Controller



Functions

Voltmeter, Ammeter, Rectification of 3-Phase input from WT6000, Isolator, Low Battery Voltage Warning, Multi-Mode Charging Control plus Solar PV connections

Mode 1 Full Charging

To 120A at nominal 48V

Mode 2 Excess Energy Divert (Battery Full)

2 DC (ECM6001 only) & 3 AC Divert Load Relays are switched in sequentially to prevent battery overvoltage (up to 5 AC Divert switches on request).

Each switch has a pre-set 'ON at' and 'OFF at' Voltages

Mode 3 Reduced 'Trickle' Charging (Dump load Fail)

Charging reduced to 20A max by series resistor on input

Mode 4 Auto-disconnect (Second Fail safe)

Wind turbine runs off load

Enclosure

IP66 Box, height:600mm, width:400mm, depth:250mm. Heatsink for rectifier on RHS adds 50mm to overall width. All connections via glands in base.

LED Indicator Display

- | | |
|-----------|---------------------------------------|
| 1. Green | Volts High, Wind turbine disconnected |
| 2. Green | Volts High, Trickle charging |
| 3. Red | Volts High, DC Dump 1 ON (ECM6001) |
| 4. Yellow | Warning, Volts Low |
| 5. Red | Volts High, DC Dump 2 ON (ECM6001) |
| 6. Red | Volts High, AC Dump 1 ON |
| 7. Red | Volts High, AC Dump 2 ON |
| 8. Red | Volts High, AC Dump 3 ON |

Layout

1. Miniature Circuit Breaker (MCB) WT Isolator
2. Terminal Strip
3. Full & trickle charge DC Contactor
4. DC Dump Contactors (ECM2501 only)
5. AC Dump Relays
6. Control Circuit (includes LED Indicator Display)

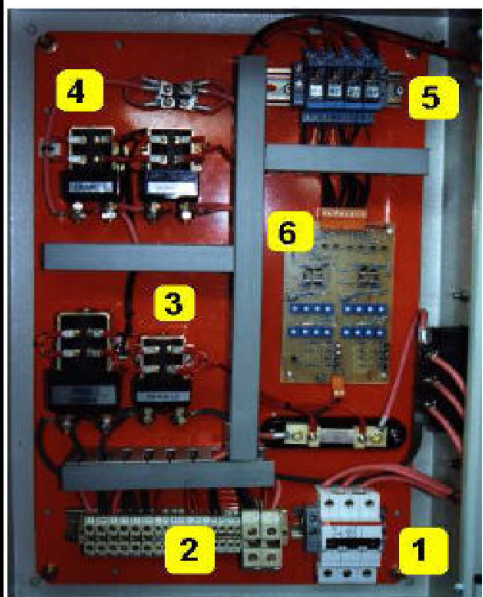

SYSTEM 1 48 V Battery Charge with 48 V Heat Dump

Suitable for DC supply systems or small inverter systems

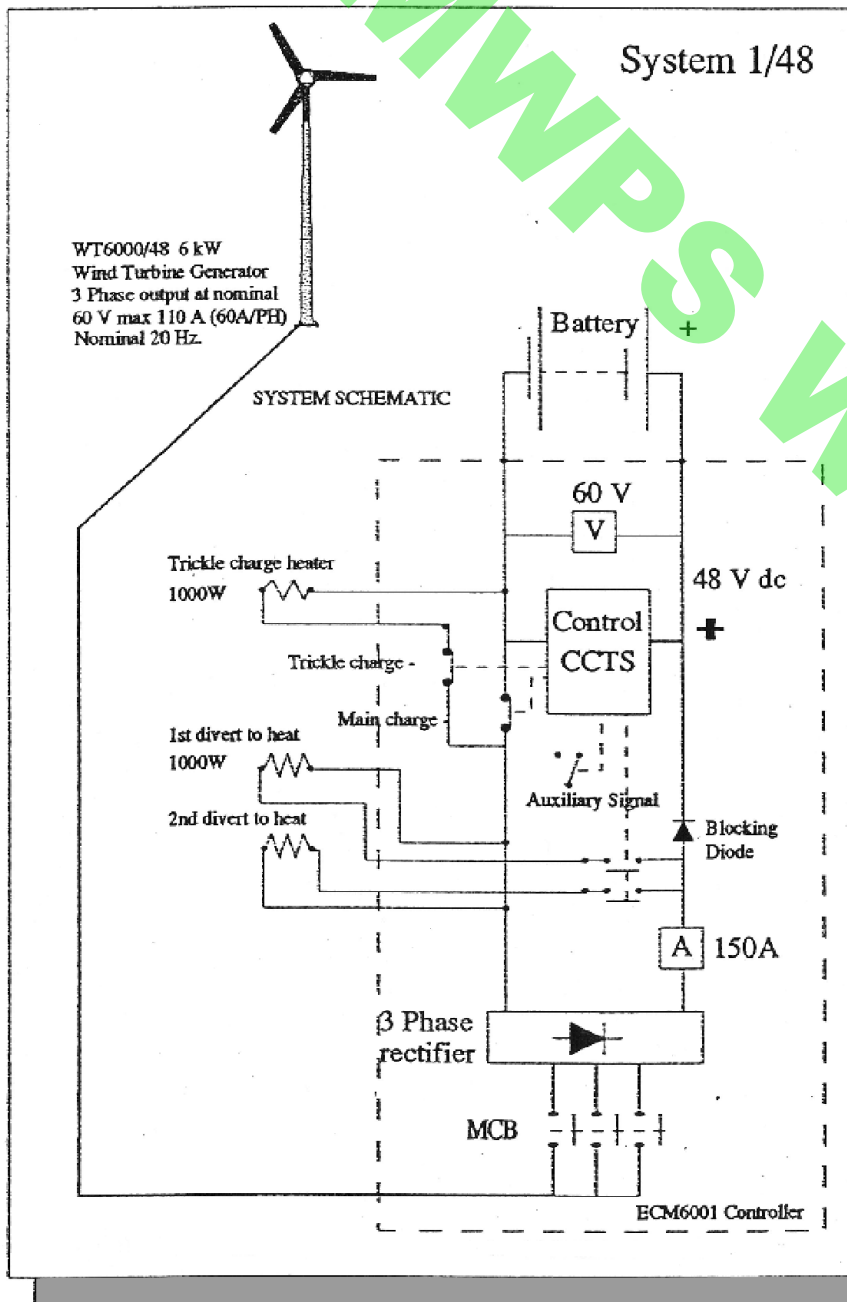

System 1 gives full power output to battery charging (at up to 110 Amperes on a 48 Volt system) until the battery is full and the voltage rises to just about gassing level.

If the battery voltage tries to rise further then a 1 kWatt 48 V heating load is switched in to use the excess power.

If the voltage still rises then a second DC load is switched in. Further divert load connections (up to 5 in total) are available - two are supplied on the standard controller. This should control the battery top voltage in most conditions; but if there is sustained high wind or a heating load is lost then if the battery Voltage rises a little further the main charge contactor opens and the wind turbine output is fed through a trickle charge heater/resistor.

If the battery Voltage still rises after all the divert loads then the trickle charge contactor opens and no power input from the Wind Turbine is allowed. The Wind Turbine then runs free and will run up to its maximum speed when the blades will turn and stall to control the speed.

Each stage is controlled by a bistable switch which has a gap between the on and off levels to provide stability. This gap is adjustable and is preset for average battery conditions.

The blocking diode is optional. When it is used the heating loads will not cycle the battery, but are directly on the Wind Turbine. This protects the battery but gives less heat output.

SYSTEM 2 48 V Battery Charge with 230 V Power Divert

Suitable for domestic supply with a large inverter

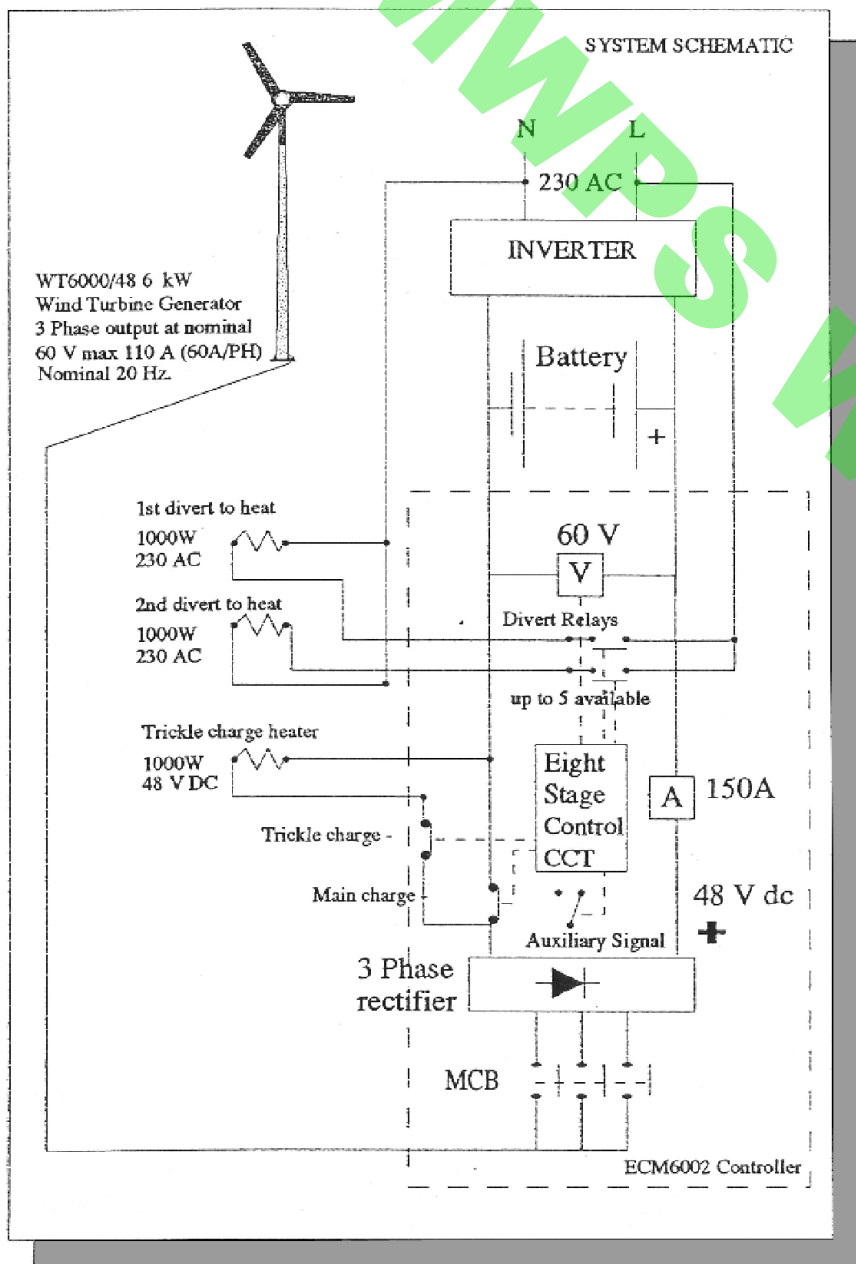

System 2 gives full power output to battery charging (at up to 110 Amperes on a 48 Volt system) until the battery is full and the voltage rises to just about gassing level.

If the battery voltage tries to rise further then a 1 kWatt 230 V AC heating load is switched in via the inverter to use the excess power.

If the voltage still rises then a second 1kWatt load is switched in. There are Eight stages of control available; One is usually used for low battery signal; Two are used for top end WT control, leaving up to Five for load divert operations; A comprehensive automatic load management system is therefore available.

If there is sustained high wind or divert loads are lost then the battery Voltage rises a little further and the main charge contactor opens and the wind turbine output is fed through a 48 V DC trickle charge heater/resistor.

If the battery Voltage STILL rises then the trickle charge contactor opens and no power input from the Wind Turbine is allowed to the battery. The Wind Turbine then runs free and will run up to its maximum speed when the blades will turn and stall to control the speed.

Each stage is controlled by a bistable switch which has a gap between the on and off levels to provide stability. This gap is adjustable and is preset for average battery conditions.

SYSTEM 1&2 CIRCUIT DIAGRAMS

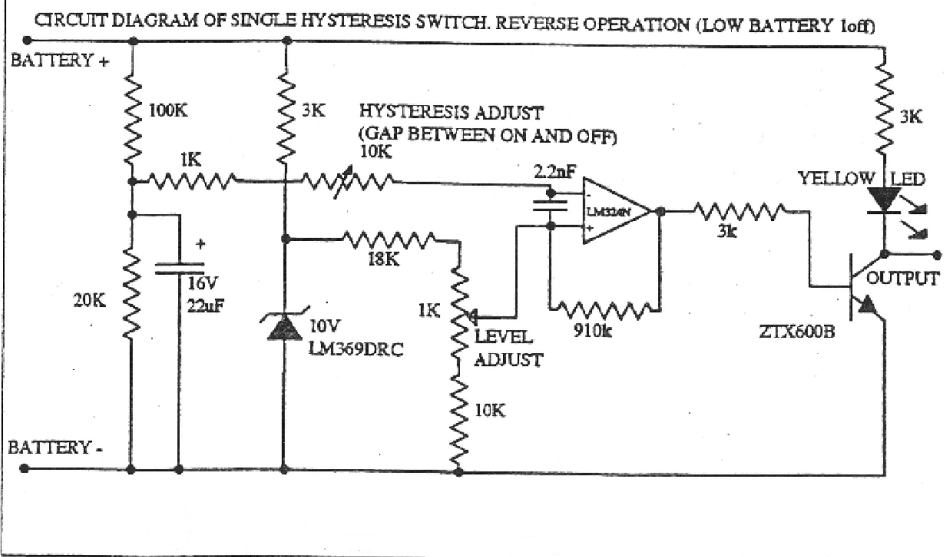
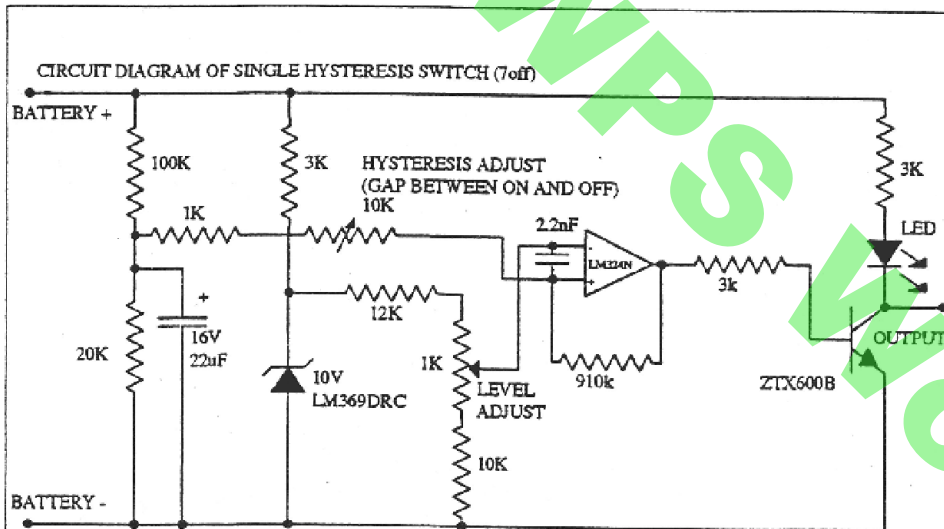

Each switch circuit uses an operational amplifier with positive feedback to give hysteresis (once switched on the input must drop by a set gap before it will switch off again). The switching level and the gap width are individually adjustable for each channel (8off).

Light Emitting Diodes indicate the state of each output.

The low battery circuit is different - its output is in the opposite sense, i.e. the output and LED come on as the battery voltage drops.

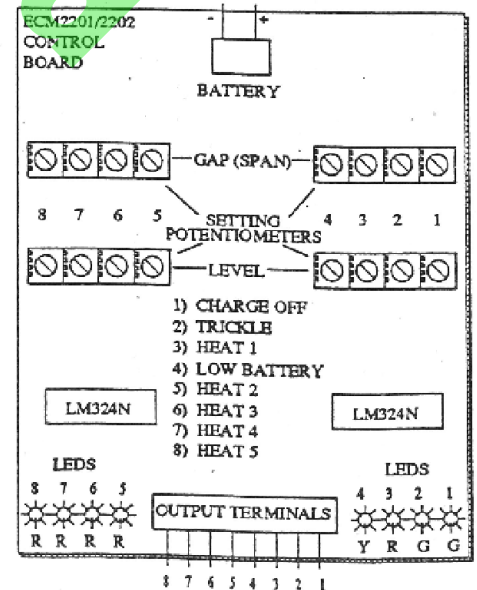

PROVEN BATTERY CHARGING SYSTEM CHECK / TEST SHEET

SYSTEM DETAILS:

JOB No: _____

Customer Details: _____

Ref: _____

COMPONENT CHECK:

Enclosure: _____

Heatsinks: _____

Rectifier: _____

Meters: _____

V: _____

A: _____

Shunt: _____

Terminals: **See Drawing**

Contactors: _____

FP: _____

TC: _____

DL: _____

Diode: _____

Relays: _____

Inhibit: _____

T.c Resistor (600W only): _____

WIRING CHECK

Connections: _____

Rectifier: _____

Shunt: _____

Contactors: _____

Diode Polarity: _____

Relays: _____

Meters: _____

CIRCUIT BOARD SETTINGS

	on	off
FP	60.50 V	56.00 V
TC	60.00 V	55.00 V
D1	56.50 V	51.50 V
LV	44.00 V	51.50 V
D2	57.50 V	52.50 V
D3	58.00 V	53.50 V
D4	58.50 V	54.00 V
D5	59.50 V	54.50 V

SIMULATION TEST

Apply variable power supply to battery terminals

V. Meter	
Operation	
Switching	
Sequence	

NOTES:

ECM No. _____

WT No. _____

Manufactured by: _____

Tested by: _____

Date: _____



The logo for Proven Energy features the word "PROVEN" in a large, blue, serif font. A blue, leaf-like graphic element curves upwards from the top of the letter "V". Below "PROVEN", the word "ENERGY" is written in a smaller, green, sans-serif font, with each letter spaced out.

PROVEN
ENERGY

WT6000 MANUAL

MECHANICAL INSTALLATION

Proven Energy Ltd,
 Wardhead Park, Stewarton,
 Ayrshire, KA3 5LH, Scotland UK
 Tel +44 (0)1560 485 570 Fax +44 (0)1560 485 580
 Email info@provenenergy.com Web www.provenenergy.com



TOOLS LIST FOR WT6000 INSTALLATION

The following is a list of parts required for the mechanical installation of a Proven WT6000 Wind Turbine.

Number	Description	Used For
2	10mm Spanners (1 open ended)	Slip Rings
2	13mm Spanners (1 open ended)	Blade back spring fixings (normally factory tightened)
2	17mm Spanners (1 open ended)	Blade fixing bolts Spring U-bracket Fixings
2	19mm Spanners (1 open ended)	Lower Yaw Bearing
2	24mm Spanners (1 open ended)	Upper Yaw Bearing Main Shaft Bearings (normally factory tightened)
1	3 mm Allen Key	Slip Rings
1	5 mm Allen Key	Yaw Bearing
1	Pair of Wire Snips	Trimming cover cable ties
1	36mm Spanner (e.g. 36mm socket on ¾" drive ratchet with 1m scaffold tube or similar for extension. 4" to 6" socket extension sometimes useful)	M24 TM900 Tower Bolts (connecting tower onto base plate)
1	Tube of glazing silicon + gun	Cover Sealant
1	Loctite Studlock (A118 or similar)	All Fixings
1 Set	Pliers, Wirestrippers, Crimping Tool etc	Wiring
1	Hacksaw	Occasionally stainless steel nuts lock during tightening. Hacksaw is sometimes the last resort! May also be used to trim foundation j-bolts if required
1	TWT532 Tirfor winch (3 tonne static) with 20m wire rope and strop for attachment at anchor pin end. Rope should be with hook at one end or loop and large D-shackle.	Raising & Lowering on standard 9m mast
1	46mm Spanner (e.g. 46mm socket on ¾" drive ratchet with 1m scaffold tube or similar for extension. 4" to 6" socket extension sometimes useful)	M30 J-bolt nuts (connecting base plate to concrete foundation)
1	Flat file	Removing any galvanising drips to allow tower fitting with yaw bearing

Please let us know if you think any tool should be added to this list

PROVEN WT6000 6KW WIND TURBINE

Cut-away view showing main shaft, bearings, generator, and slip rings.

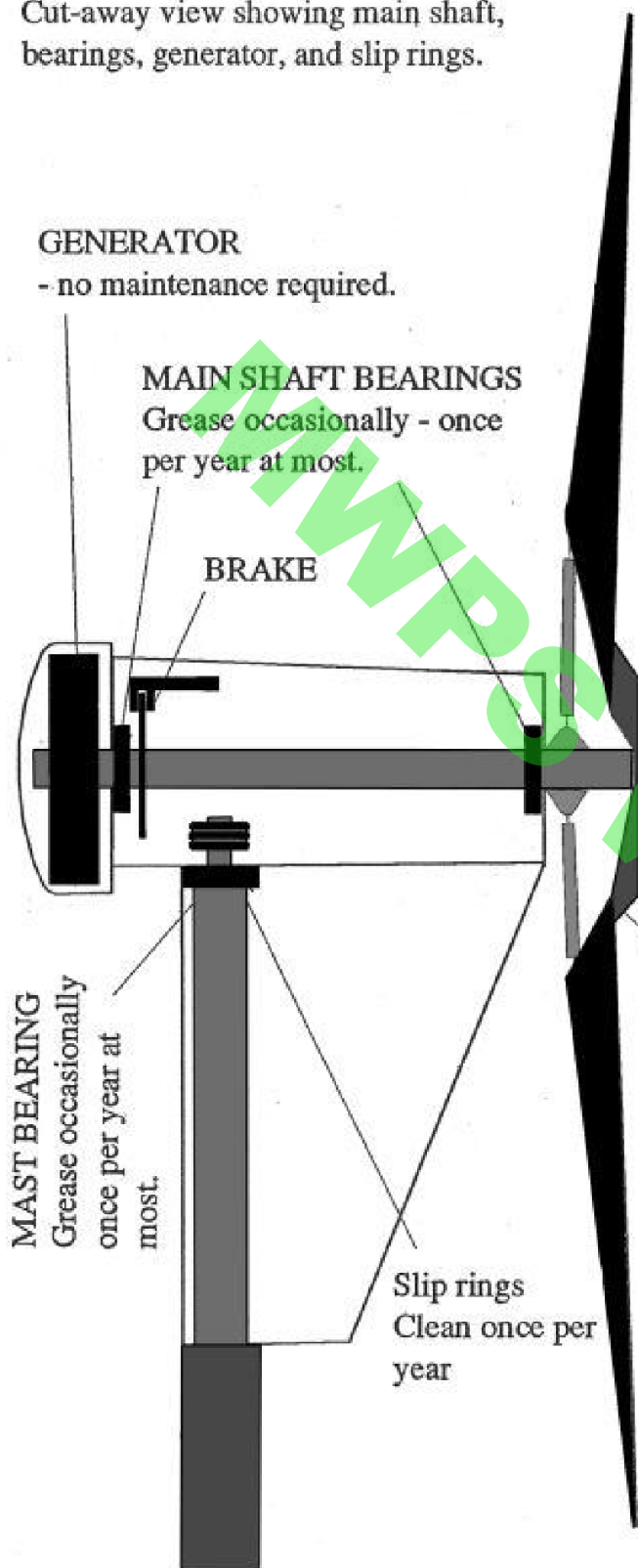

Maintenance Schedule

Once per year:
Grease the three bearings,
Clean slip rings
Check Brake pads
Check nuts and bolts.
Check springs

Operation

No action is required during normal running the system is self regulating and automatic with passive fail-safe speed and power control.

Proven Patent Passive Blade control system

PROVEN ENERGY LTD

Wardhead Park, Stewarton, Ayrshire,
KA3 5LH, SCOTLAND
TEL: ++44 (0) 1560 485 570
E-MAIL: info@provenenergy.com

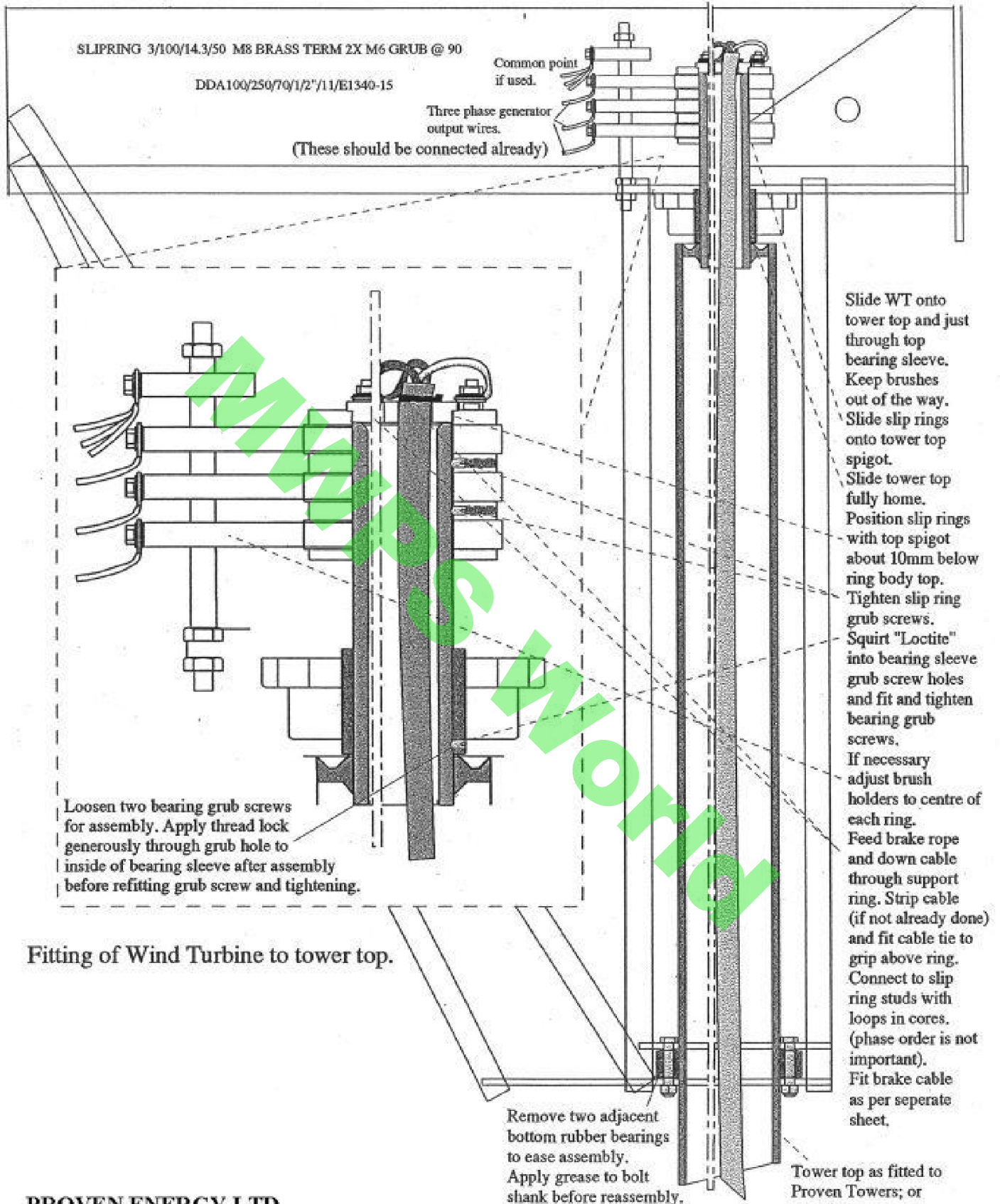

Fitting of Wind Turbine to tower top.

PROVEN ENERGY LTD
Wardhead Park, Stewarton, Ayrshire,
KA3 5LH, SCOTLAND
TEL: ++44 (0) 1560 485 570
E-MAIL: info@provenenergy.com

FITTING THE WT6000 6kW

WIND TURBINE TO THE TOWER TOP



See also WT6000 Fitting Diagrams

- If fitted, remove covers by cutting the securing cable ties.
- Remove at least two of the rubber rollers to make it easier to fit the frame onto the tower top.
- Carefully slide the frame onto the tower until the tower top spigot is just through the bearing sleeve.
- As the turbine is pushed fully home fit the slip rings whilst keeping the brushes out of the way,
- The yaw bearing fixing bolts can now be tightened. They are left loose to assist the fitting. Ensure turbine is pushed fully home and tighten bearing grub screw. (Use a thread locking compound to prevent vibrating loose)
- The rubber rollers can now be refitted. Grease the bolt shank before assembly. Do not overtighten the rubbers so that they will not rotate.
- Position slip rings so that they overhang the tower spigot by about 10mm. This allows room for the “top hat”.
- Using thread lock compound tighten the slip rings retaining grub screws.
- Check brushes are in line and making good contact with slip rings. Adjust as necessary.
- Remove slip ring stud nuts and washers. Feed cable down into tower top. Strip outer insulation and push cable through “top hat”. Fit a cable tie to take the weight of the cable as shown in the diagram.
- Push “top hat” onto slip rings and using ring crimps fit cables to the relevant studs and check they are clear of the shaft. For a three-phase output machine the three cables can be connected in any order.

N.B. For a turbine with DC output (i.e. rectifier mounted within turbine) check the polarity of the connections).

- Check everything is tight and that the turbine will freely rotate within its yaw axis.
- Refit covers as per instructions.
- Fit blades as per instructions.
- Finally spin the rotor by hand to check that nothing rubs. If the turbine has been roughly handled then the domed generator cover can get pushed against the magnet plates. If this is the case gently tap the cover back into position and reseal if necessary with silicone.

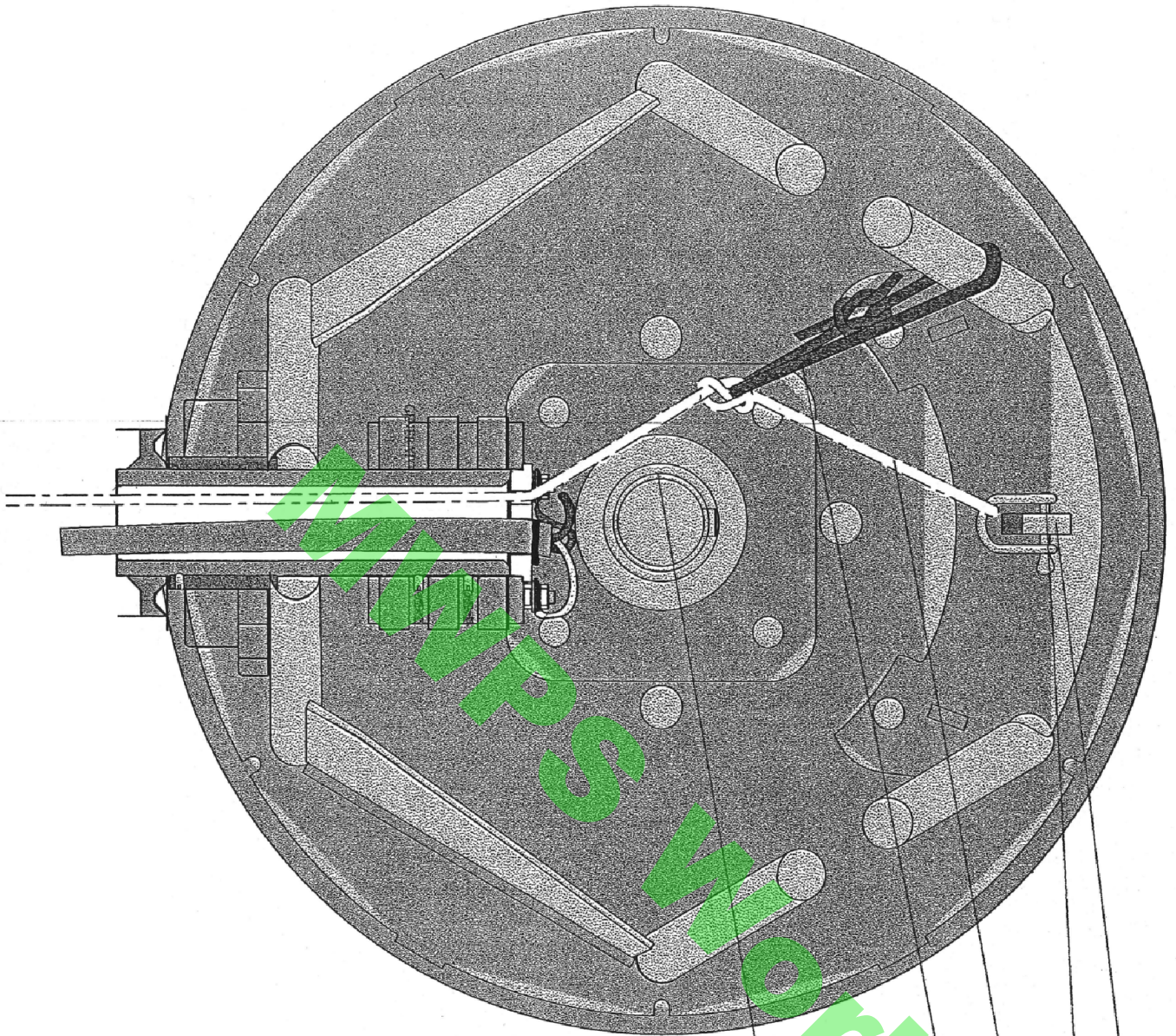

Brake Lever

Brake shackle; apply threadlock to threads.

Brake rope

Brake Elastic

This serves to take the weight of the brake rope and holds the rope away from the shaft while running.

When the brake is applied the rope leans against the stopped shaft.

View looking from rotor to generator.

WT2500

Brake rope arrangement

brakerop2 MI 002

PROVEN ENERGY LTD

Wardhead Park, Stewarton, Ayrshire,
 KA3 5LH, SCOTLAND
 TEL: ++44 (0) 1560 485 570
 E-MAIL: info@provenenergy.com

Proven WT6000 Blade fitting instructions

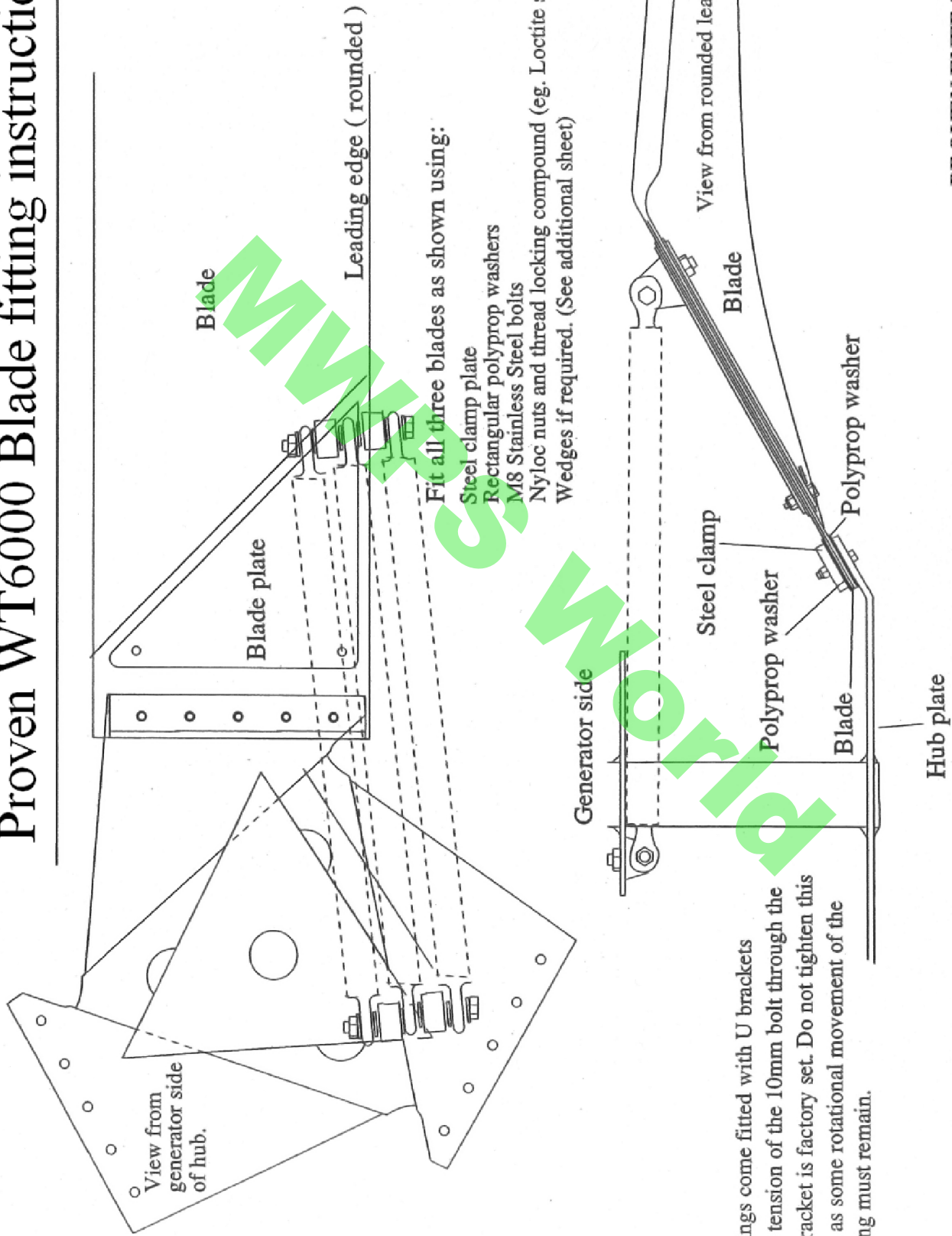

PROVEN ENERGY LTD
 Wardhead Park, Stewarton, Ayrshire,
 KA3 5LH, SCOTLAND
 TEL: ++44 (0) 1560 485 570
 E-MAIL: info@provenenergy.com

bladefird3

© PROVEN ENERGY LTD

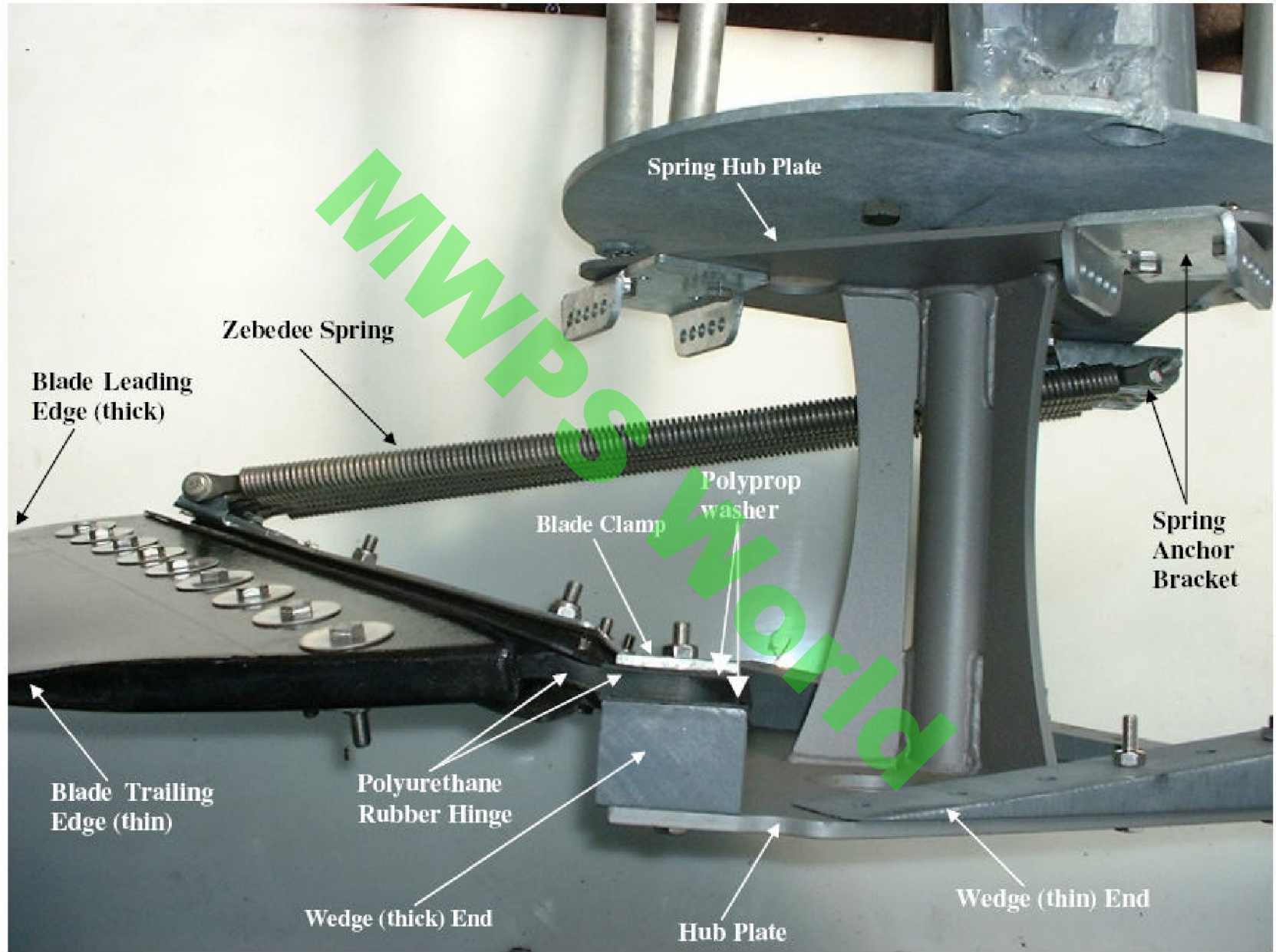

Blade Leading Edge (thick)

Zebedee Spring

Blade Trailing Edge (thin)

Polyurethane Rubber Hinge

Wedge (thick) End

Blade Clamp

Hub Plate

Spring Hub Plate

Polyprop washer

Spring Anchor Bracket

Wedge (thin) End

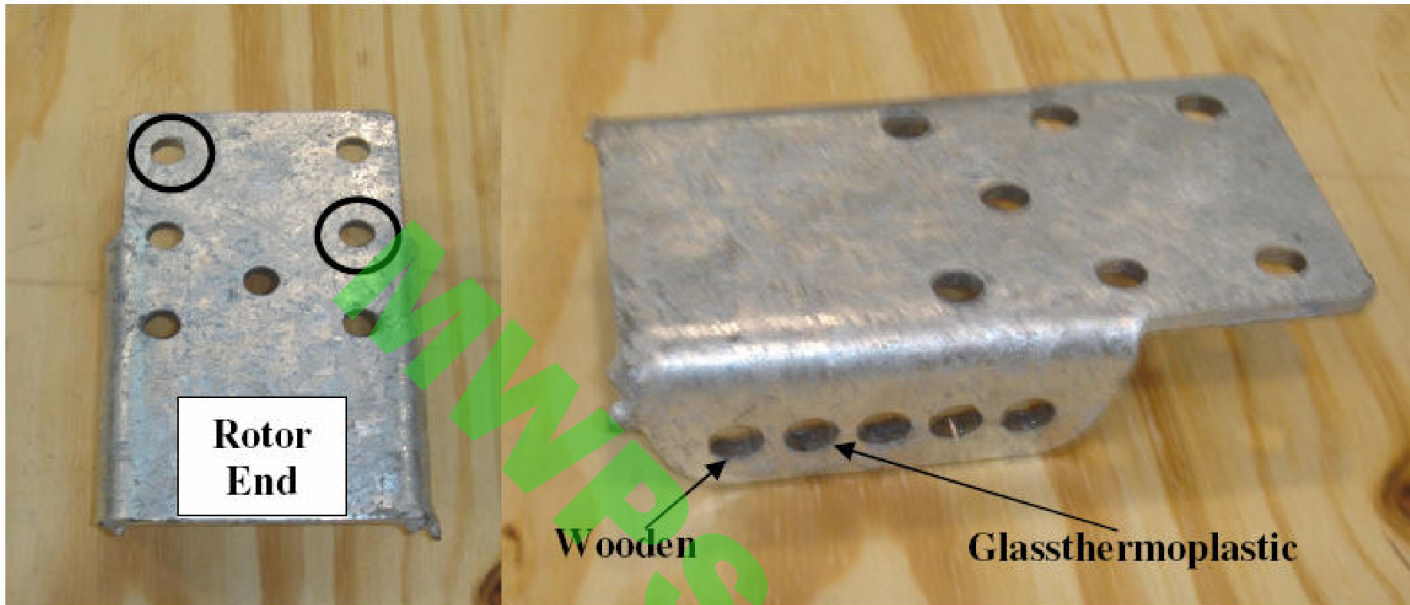

Spring blade bracket

Spring anchor bracket

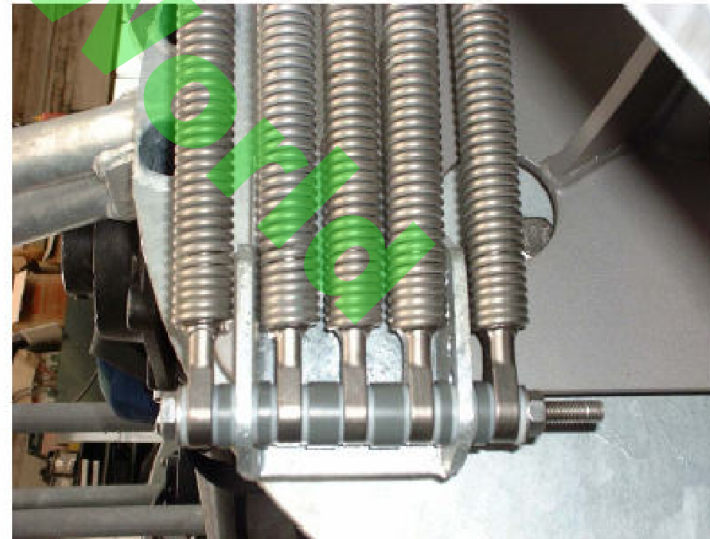
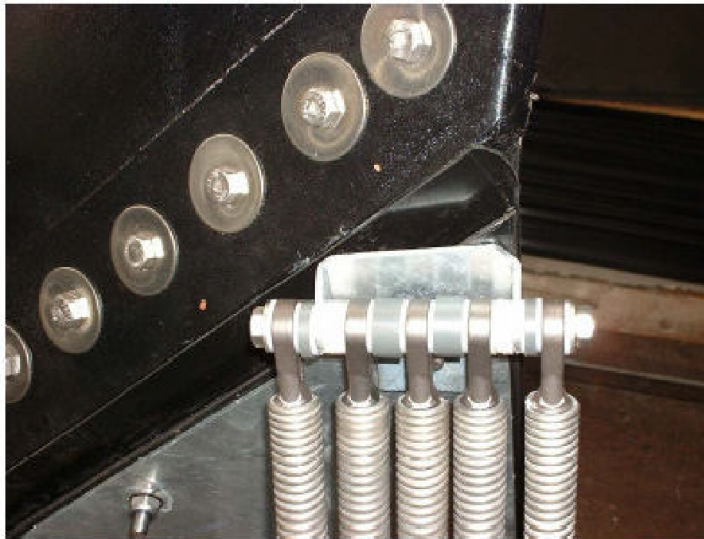

COVER FITTING



See also WT6000 Cover Fitting Diagram

The two 3mm polyprop covers are secured to the turbine with at least 4.2mm cable ties. When fitting covers leave the ties loose until all ties are fitted and the covers pushed firmly into position.

Fit the lower cover first. Fix the cable ties in the order shown (A, B, etc.). When fitting the top cover note the corners which are cut. One corner has a longer cut edge which gives clearance for the cable conduit.

- A. Tie goes through hole and around frame spar. Repeat both sides. Push cover under the frame spar.
- B. Through hole, around spar and out of second hole. Repeat both sides.
- C. Through hole, through hole on other side of cover, round and back out.
- D. Use one long tie or join two short ties together. Tie goes through cover, into one frame hole, out of the second, through cover and then fastened. This should pull the cover flat to the frame.
- E. Tie through cover and around spar.

Push the lower cover firmly up so the top edges but inside the horizontal spars of the space frame. The ties on the lower cover can now be tightened and trimmed off. Now tighten the top cover while pushing it firmly against the generator housing. Check that it does not rub against the spring anchor plate on the shaft.

Using a silicon sealant fill the gap between the cover and generator housing to keep water out of the turbine. If not already done also seal the domed generator cover.

FITTING THE BLADES

Throughout the blade fitting process be careful of them - they are fragile. Protect the blade tips, leading and trailing edges with padding if necessary (stones on ground etc).

Fit one blade to the hub as shown in diagram 6000 blade fit diagram 2 (ref: 6000 MI 012/2) as follows.

1. Place wedge onto hub
2. Put polyprop (plastic) washer on top of wedge
3. Place PU (rubber) hinge of blade on top of washer
4. Place further washer on top with metal clamp plate as final layer
5. Secure blade using M10 bolts and lock nuts provided. It is good practice to use Loctite Threadlock (A118 or similar) to lubricate **and** secure fixings against vibration. Use only a **small** amount on each bolt.
6. Referring to diagram 6000 MI013 attach zebedee springs to the blade bracket and spring anchor bracket.
7. It is **very** important that the M10 fixing bolt running through the spring ends is not fully tightened. The spring ends should be allowed to freely rotate during normal operation. However, there should be no lateral play of the spring ends within the spring bracket.
8. Check all fasteners are tight and repeat for the other two blades.

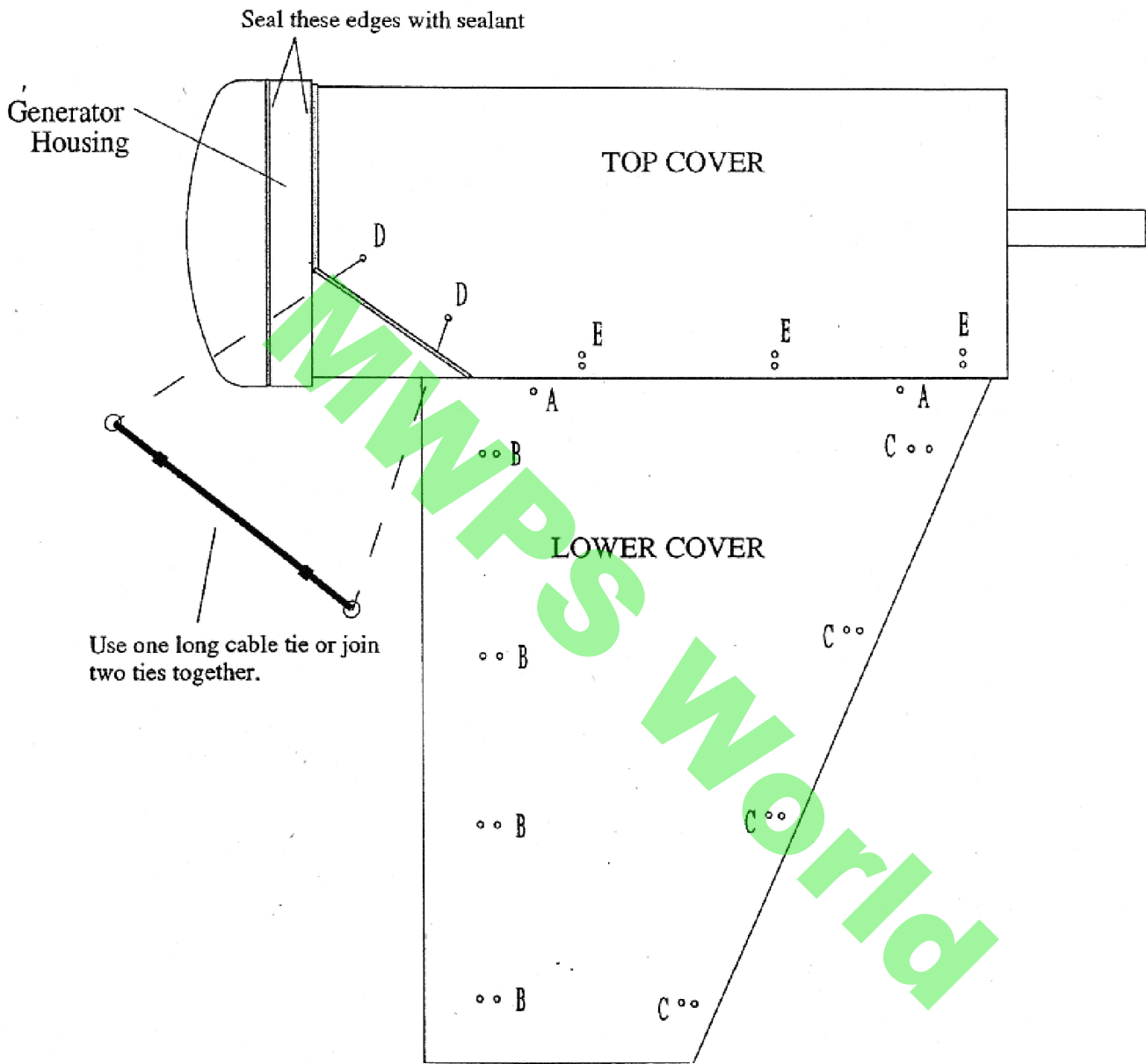

WT6000 Cover Fitting Diagram

**IMPORTANT
SAFETY
INFORMATION**

Instructions for Safe Use of: Shackles

The information in this leaflet should be passed to the user of the equipment

This document is issued in accordance with the requirements of Section 6 of the Health and Safety at Work etc Act 1974, amended March 1988. It outlines the care and safe use of SHACKLES and is based on Section 4 of the LEEA Code of Practice for the Safe Use of Lifting Equipment.* It should be read in conjunction with the requirements for general purpose slinging practice given overleaf, the principles of which may be applied to the use of shackles with or without slings.

This information is of a general nature only covering the main points for the safe use of shackles. It may be necessary to supplement this information for specific applications.

ALWAYS:

- Store and handle shackles correctly.
- Inspect shackles before use and before placing into storage.
- Select the correct pattern of shackle and pin for the application.
- Allow for the full resultant imposed load.
- Fully tighten the pin.
- Ensure the load acts through the centre line of the shackle using spacers if necessary to meet this requirement.

NEVER:

- Use shackles with bent pins or deformed bodies.
- Force, hammer or wedge shackles into position.
- Eccentrically load shackles.
- Replace the pin with a bolt.
- Fit pins in contact with moving parts which may loosen or unscrew them.
- Shock load shackles.

Selecting the Correct Shackle

Shackles are available in a range of material grades, sizes and designs. Select the shackle to be used and plan the lift taking the following into account:

Type of shackle to be used - dee or bow, British Standard or other design.

Type of pin - screwed with collar and eye are suitable for general purposes; with countersunk head for where clearance is limited; bolt and nut for where the pin may be out of sight or subject to movement.

Full resultant imposed load - when using shackles with multi-leg slings remember that as the included angle increases and so does the load in the leg and any attachment to the leg. When used to suspend pulley blocks account must be taken of the imposed load due to operating effort.

CAUTION: BS and ISO Standard shackles are designed and rated for the pin to accept a central point load. Other commonly available types are designed and rated for the load to be evenly distributed over the full width of the pin. Unless the basis for rating is clearly stated it should be assumed that the jaw must be fully filled and the load evenly spread across the shackle pin width.

Storing and Handling Shackles

Never return damaged shackles to storage. They should be dry, clean and protected from corrosion.

Do not alter, modify or repair shackles and never replace missing pins with unidentified pins, bolts etc, but refer such

matters to a Competent Person.

Never galvanise or subject a shackle to other plating processes without the approval of the supplier.

Using Shackles Safely

Do not attempt lifting operations unless you understand the use of the equipment, the slinging procedures and the mode factors to be applied.

Do not use defective shackles or unidentified pins.

Shackles should be fitted so that the body takes the load along its centre line and is not subjected to side bending loads. When connecting a number of sling legs, and similar applications, position them so that they do not impose a side load on the shackle jaws. Use spacers to position them if necessary.

Ensure the pin is correctly screwed into the shackle eye. Tighten by hand, use a small bar to lock the collar to the shackle eye. Check that the thread is fully engaged with the body but is not too long so that tightening causes the body to deform.

With bolt and nut pins ensure the nut jams on the inner end of the thread and not on the eye of the shackle. The bolt should be free to rotate with minimal side float. The split cotter pin must be fitted before making a lift.

When using shackles with slings in choke hitch, or in other applications where there may be movement, place the pin through the eye or link of the sling, and never in contact with the bight of the choke or moving parts which may cause the pin to unscrew.

In-service Inspection and Maintenance

Maintenance requirements are minimal. Keep shackles clean, the threads free of debris and protect from corrosion.

Regularly inspect shackles and, in the event of the following defects, refer the shackle to a Competent Person for thorough examination: illegible markings; distorted, worn, stretched or bent body; bent pin; damaged or incomplete thread forms; nicks, gouges, cracks or corrosion; incorrect pin; any other defect.

© Lifting Equipment Engineers Association 1994 SI No 6.0

Further information is given in:

* The Code of Practice for the Safe Use of Lifting Equipment, published by:

LIFTING EQUIPMENT ENGINEERS ASSOCIATION,



Waggoners Court, The Street,
Manuden, Bishop's Stortford,
Herts, CM23 1DW.

Tel: 01279 816504 Fax: 01279 816524

CERTEX

Lifting Products and Services

Instructions for Safe Use of: Winches Used For Lifting

The information in this leaflet should be passed to the user of the equipment

This document is issued in accordance with the requirements of Section 6 of the Health and Safety at Work etc Act 1974, amended March 1988. It outlines the care and safe use of WINCHES USED FOR LIFTING and is based on Section 19 of the LEEA Code of Practice for the Safe Use of Lifting Equipment.* It should be read in conjunction with the requirements for lifting appliances for general purposes, given overleaf, which form an integral part of these instructions.

This information is of a general nature only covering the main points for the safe use of winches used for lifting. It may be necessary to supplement this information for specific applications.

ALWAYS:

- Store and handle winches correctly.
- Inspect the winch, rope and accessories before use and before placing into storage.
- Ensure mounting and suspension points are secure and suitable for the full loads that will be imposed.
- Lift the load just clear, halt for a short period to ensure the integrity of the brake or sustaining mechanism before completing the lift.
- Use a speed appropriate to the specific application.
- Keep hands and feet clear of ropes, drums etc.

NEVER:

- Raise loads by revolving the drum in the opposite direction to that indicated.
- Use winches with loose or insecure handles.
- Use the pawl to arrest descending loads.
- Use winches if the rope is twisted or trapped.
- Over wind the rope on or off the drum.
- Use winches for man-riding applications unless they are specifically designed for that purpose.

Selecting the Correct Winch

Winches are available for manual or power operation in a range of capacities, designs and mounting arrangements. Select the winch to be used and plan the lift taking any statutory requirements and the following into account:

Type of winch - manual, electric, pneumatic or other operation - mounting, eg wall, floor, lorry etc - capacity and rope drum storage etc.

Speeds and control - single speed, dual speed - push button, pull cord, lever, remote etc.

Rigging arrangement - diverters, pulley blocks - anchorage and suspension points - imposed loads.

Consult the supplier if the winch is to be used in areas of high risk, exposed to the elements, water, steam etc, with hazardous substances, eg acids or chemicals, or subjected to extremes of temperature.

Storing and Handling Winches

Never return damaged winches, ropes etc to storage. They should be dry, clean and protected from corrosion.

With winches used for temporary applications, remove the rope for separate storage or wind it fully onto the drum and lash in position to prevent damage.

With winches left in situ, remove pulleys etc and wind the rope fully onto the drum. Where this is not possible, pulleys etc should be positioned to protect them from damage and so as not present a danger to persons or other equipment. Isolate any power supply.

Installing and Commissioning

Follow the specific instructions for installation and commissioning issued by the supplier. Handle the rope carefully. If the winch fails to operate correctly contact the supplier.

Using Winches Safely

Do not use defective winches, ropes, pulleys etc.

Check the rigging arrangement, that mounting and suspension points are secure and adequate for the imposed loads. Do not use timber bearers. Ensure sheaves are correct for size and type of rope, that fleet angles are not too great, the rope is not twisted and the load is free to move. Check operating handles are secure.

Raise the load just clear, halt the lift to ensure the integrity of the brake, slinging arrangement etc.

With manual winches, only the slow speed should be used to raise/lower loads. With power operated winches, select a speed appropriate to the specific lifting operation.

Ensure oil, water or other foreign matter does not come into contact with lined brakes.

If the direction of rotation is indicated the winch must raise the load when turning in that direction.

Check the rope and load travel paths are clear and you have a clear view so as to avoid accidents or collisions. Do not over wind the rope on or off the drum. Two turns must always remain on the drum. (This is a requirement of the Construction (Lifting Operations) Regulations however some manufacturers design for more and their recommendations must be followed.)

Keep clear of ropes, pulleys, drums and other moving parts.

In-service Inspection and Maintenance

Follow the specific instructions for maintenance issued by the supplier. These should be incorporated into the site maintenance programme observing any particular needs due to the site or working conditions.

Regularly inspect the winch and, in the event of the following defects, refer to a Competent Person for thorough examination: mounting insecure; loose or missing bolts; winch frame distorted; rope drum flanges chipped or cracked; rope anchorage loose or pulled; ratchet or pawl worn; brake worn or slipping; rope worn, or winding incorrectly; broken wires; gears worn, or not positively locating; any other visible damage, corrosion, defects or operational faults.

© Lifting Equipment Engineers Association 1994 SI No 15.0
Further information is given in:

- * The Code of Practice for the Safe Use of Lifting Equipment, published by:

LIFTING EQUIPMENT ENGINEERS ASSOCIATION,



Waggoners Court, The Street,
Manuden, Bishop's Stortford,
Herts, CM23 1DW.

Tel: 01279 816504 Fax: 01279 816524

PROVEN

WORLD FRIENDLY ENERGY



INSTRUCTIONS FOR SAFE USE OF WIRE ROPE GRIPS

The information in this leaflet should be passed to the user of the equipment

As a result of the shortcomings in B.S. wire rope grips as evidenced by research carried out by the Health and Safety Executive, the relevant standard i.e. B.S.463:1983 has been withdrawn.

CERTEX (UK) market wire rope grips in accordance with D.I.N. 1142. These grips have also been extensively tested by H.S.E and have been found to be efficient when installed correctly.

Having a flat faced bridge the D.I.N. 1142 grip is compatible with six, eight and multistrand ropes in either right or left hand lay.

Required number and torque.

Nominal size	Required number of wire rope grips to attain 85% of rope min. Breaking load	Required tightening torque to attain required efficiency (N.m)
5	3	2.0
6.5	3	3.5
8	4	6.0
10	4	9.0
13	4	33.0
16	4	49.0
19	4	68.0
22	5	107.0
26	5	147.0
30	6	212.0
34	6	296.0
40	6	363.0

For intermediate sizes of rope the next largest grip size should be used in conjunction with the corresponding torque.

The nominal size 5 grip should not however be used on ropes having nominal diameters of less than 4.0 mm.

Fitting

The first grip must be placed immediately against the thimble. The grips must be placed so that they are separated by a distance of approximately

six rope diameters

The "U" bolt must always be placed on the tail end of the rope (non load bearing end)

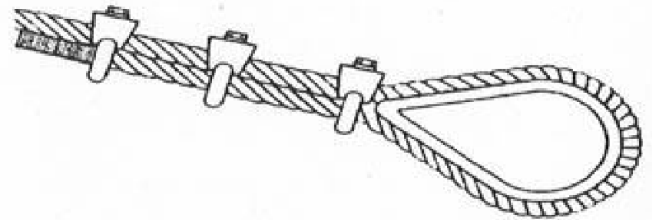

During assembly and before the rope is taken into service, the nuts must be tightened to the prescribed torque. After application of the load, the torque must be checked and if necessary, be corrected.

This action should be repeated within 24 hours of installation.

Further periodic checking and re-torquing of the nuts is essential during service, particularly during the early stages of operation to ensure that the

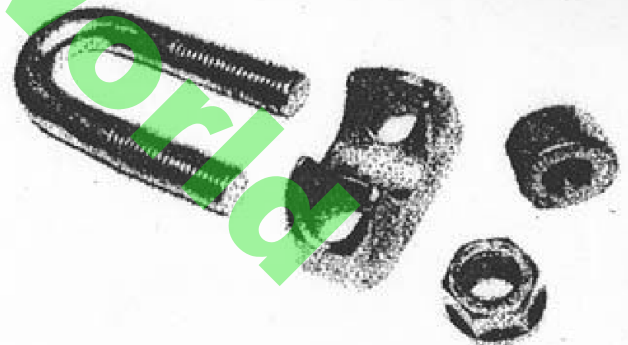

terminal efficiency is maintained

Further details on D.I.N. 1142 grips can be obtained from your local CERTEX (UK) sales office.

CERTEX
Lifting Products and Services

LEFT SIDE

RIGHT SIDE



TU-8

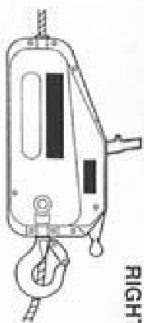

TU-16

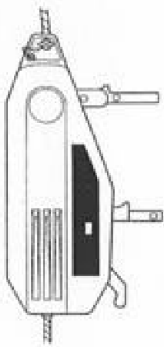

TU-32

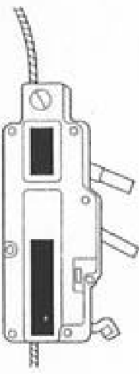
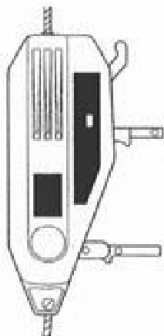

T-508D
T-516D

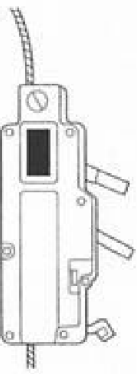
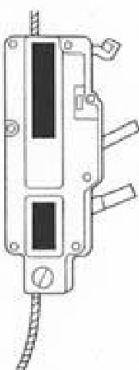

T-532D

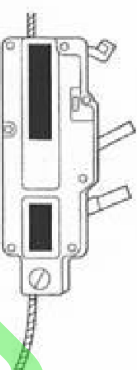

Ensure that the labels indicated above in black are in place.
Replacement labels can be supplied on request.

Accessories for TIRFOR machines



Hook
for TIRFOR
T-500D
and TU-32

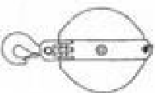

Pulley blocks
and side operating blocks



Slings



Ground anchors

008608626 - Ind 01 - 09/2001

TRACTEL S.A.S.

RN 19 Saint Hilaire sous Romilly
F 10102 Romilly-s-Seine
Tel. (+33) 3 25 21 07 00
Fax (+33) 3 25 21 07 11
ISO 9001

TRACTEL UK Ltd

Old Lane - Halfway
SHEFFIELD S 20 3GA
Tel. 44 (0114) 248 2266
Fax 44 (0114) 247 3350
ISO 9001

SECALT S.A.

3, rue du Fort Dumoulin
B.P. 1113 • L-1011 Luxembourg
Tel. (352) 43 42 42-1
Fax (352) 43 42 42-200
ISO 9001

© ALL RIGHTS RESERVED
Manufactured in France

tirfor®

lifting and pulling machines

operating and maintenance instructions

models

TU : TU-8

TU-16

TU-32

T-500D : T-508D

T-516D

T-532D

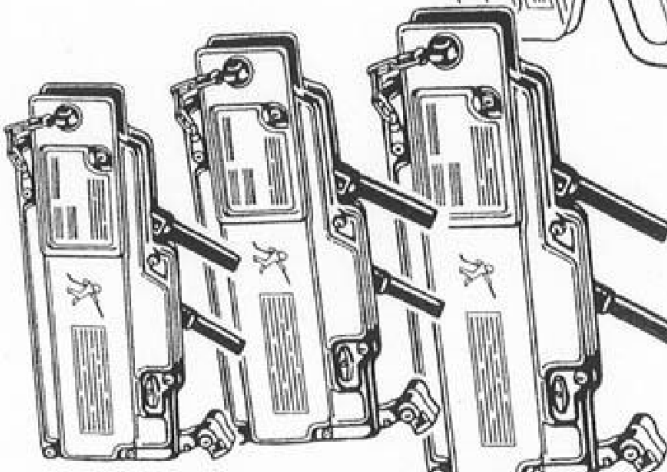
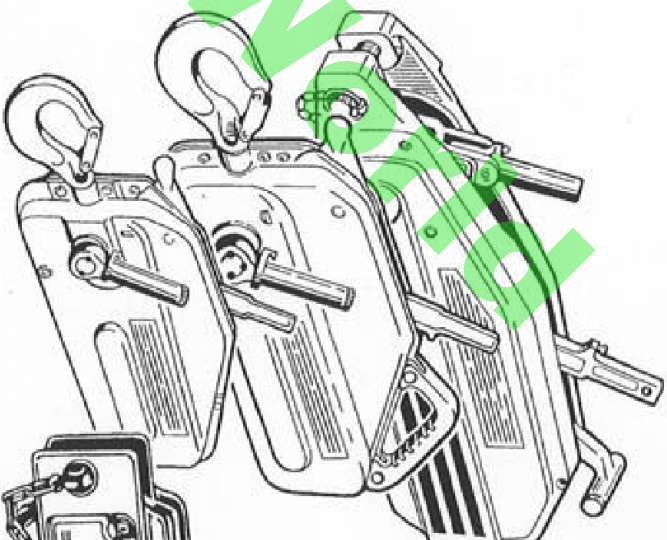

equipment in
accordance with
CE directives



ORIGINAL MANUAL

CONTENTS	Page
General warning	3
Technical data	3
1. Description of equipment	4
2. Rigging arrangements	4
3. Installing the wire rope	5
4. Releasing and closing the jaws	5
5. Anchoring	7
6. Operation	8
7. Releasing the wire rope and storage	8
8. Safety devices	9
9. Replacing the shear pins	9
10. Maxiflex wire rope	10
11. Maintenance instructions	10
12. Warnings against hazardous operations	11
13. Troubleshooting	11
14. Health and safety at work	11

Always concerned to improve the quality of its products, the TRACTEL Group reserves the right to modify the specifications of the equipment described in this manual. The companies of the TRACTEL Group and their agents or distributors will supply on request descriptive documentation on the full range of TRACTEL products: jiffing and pulling machines, permanent and temporary access-equipment, safety devices, electronic load indicators, accessories such as pulley blocks, hooks, slings, ground anchors, etc...

The TRACTEL network is able to supply an after-sales and regular maintenance service. Should you have any queries or require technical assistance, please do not hesitate to contact TRACTEL UK.

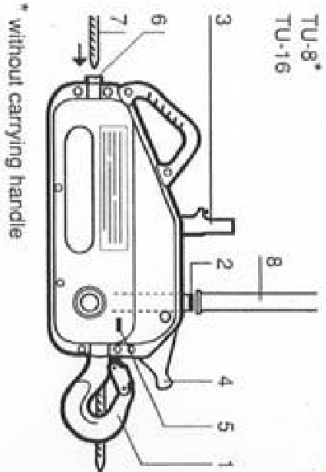
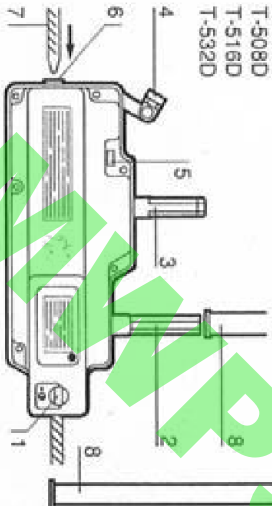
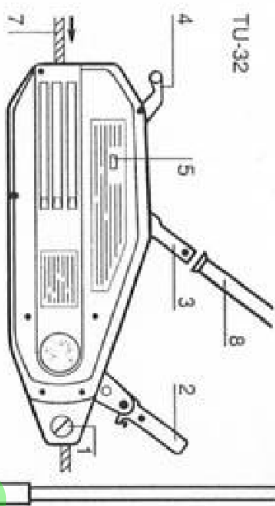

Fig. 1

* without carrying handle



1. Hook / anchor pin
2. Forward operating lever
3. Reverse operating lever
4. Rope release lever
5. Rope release safety catch
6. Rope guide
7. Maxiflex wire rope
8. Telescopic operating handle



Wire rope on reeler

operating levers to allow the lubricant to penetrate all parts of the mechanism.
N.B. Excess lubrication cannot cause the machine or wire rope to slip.

Any machine where the side cases show signs of dents or damage, or a which the hook is damaged (models TU-8 and TU-16), should be returned to an approved repairer of TRACTEL UK.

12. ⚠ WARNINGS AGAINST HAZARDOUS OPERATIONS ⚠

The operation of TIRFOR machines, in accordance with the instructions of this manual, is a guarantee of safety. Nevertheless, it is useful to draw the attention of users to the following warnings:

- TIRFOR machines as described in this manual must not be used for lifting people.
- Never attempt to motorise the models of TIRFOR machines described in this manual.
- TIRFOR machines must not be used beyond their maximum working load.
- TIRFOR machines must not be used for applications other than those for which they are intended.

- Never attempt to operate the rope release mechanism whilst the machine is under load.
- Never obstruct the operating levers or the rope release lever.
- Never operate the forward and reverse operating levers at the same time.
- Never use a handle, other than the telescopic operating handle supplied, to operate the TIRFOR machine.
- It is forbidden to replace sheared pins by anything other than genuine TIRFOR shear pins of the same model.
- Never anchor the machine other than by its appropriate anchor point.
- Never obstruct the machine, which could prevent the machine, the wire rope and the anchor points from operating in a straight line.
- Never use the TIRFOR MAXIFLEX wire rope as a sling.

14. HEALTH AND SAFETY AT WORK

All lifting equipment must be supplied, operated, maintained and tested according to the applicable statutory requirements, and specially to the provisions of the Health and Safety at Work Act. It is also the responsibility of every company to ensure that their employees have been fully and properly trained in the safe operation of their equipment.

- Never apply a load to the loose wire rope exiting from the anchor point of the TIRFOR machine.
- Never subject the controls to sharp knocks.
- Never attempt to reverse the rope completely through the machine whilst under load.
- Do not operate the TIRFOR machine when the rope ferrule gets to within 10 cm of the machine. Otherwise the ferrule is likely to foul the casing and push the rope guide inside the machine.

13. TROUBLESHOOTING

1) The forward operating lever moves freely and does not operate the mechanism :
the machine has been overloaded and the shear pins have sheared. See section 9 for replacing the shear pins.

2) Pumping :

A lack of lubricant in a TIRFOR machine sometimes brings about a condition known as "pumping" which is not at all dangerous, but which is inconvenient. This situation occurs when the jaw which is gripping the rope becomes locked onto it preventing the other jaw from taking over the load. As the operating lever is moved in one direction the machine travels a few centimeters, but when the operating lever travels in the other direction the machine moves back the same distance in sympathy with the jaw which is locked onto the rope. The TIRFOR machine should be thoroughly lubricated and it will recommence working normally.

3. Jerkiness :

This is also a symptom of lack of lubrication. The TIRFOR machine should be thoroughly lubricated.

4. Blockage :

If the wire rope becomes blocked in the machine, generally because a damaged section of wire rope is stuck within the jaws, it is imperative to stop operating the machine. The load should be taken by another machine on a separate wire rope, or by another means, whilst ensuring that all safety precautions are taken. When the blocked machine is no longer under load, the damaged rope may be released and removed. Should this not be possible, return the machine and wire rope to TRACTEL UK or an approved repairer.

10. MAXIFLEX WIRE ROPE

⚠ To guarantee the safe operation of TIRFOR machines, it is essential to use them exclusively with TIRFOR MAXIFLEX wire rope which has been specially designed to meet the requirements of the TIRFOR machine.

TIRFOR MAXIFLEX wire ropes have a red strand which is visible on new rope. One end of the wire rope has an end fitting, such as a safety hook, fitted to a thimble fixed by a metal ferrule (See Fig. 21). The other end of the wire rope is fused and tapered (See Fig. 22).

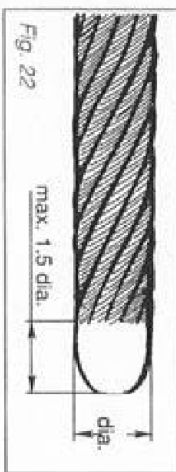
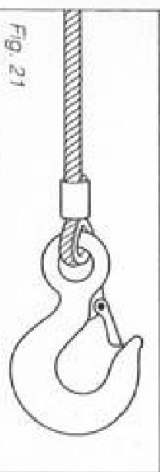

⚠ A wire rope in good condition is a guarantee of safety, to the same extent as a machine in good condition. It is necessary to continuously monitor the state of the wire rope, to clean and oil it with a rag soaked with motor oil or grease. Grease or oil containing graphite additives or molybdenum disulphide must not be used.

Visual examination of the wire rope

The wire rope should be examined daily to detect any signs of wear (damage or broken wires). See examples in Fig. 23). In case of any apparent wear, have the wire rope checked by a competent person. Any wire rope with a reduction from the nominal diameter by more than 10% should be replaced. (See Fig. 24 for the correct method of measuring the diameter of a wire rope).

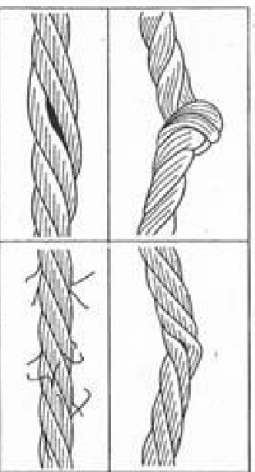
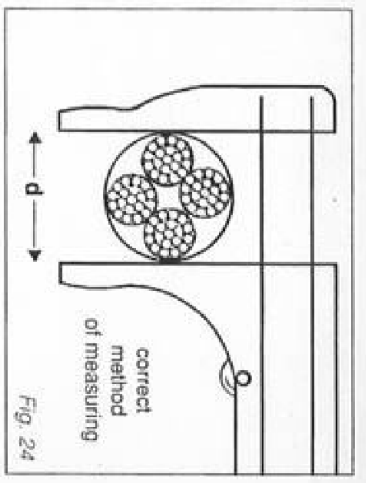

Fig. 23 - Examples of damaged wire rope



IMPORTANT : It is recommended, specially for lifting applications, to ensure that the length of wire rope is greater than actually required. Allow an extra meter approximately.

When lifting or lowering loads over long lengths of wire rope, steps should be taken to stop the load from rotating to prevent the wire rope from unlaying. Never allow a tensioned wire rope to rub over sharp edges. The wire rope must only be used with pulleys of an appropriate diameter. Never expose the wire rope to temperatures beyond 100 degrees C.

Never use wire rope that has been subject to damage such as fire, corrosive chemicals or atmosphere, or exposed to electric current. Storage : See section 7.

11. MAINTENANCE INSTRUCTIONS

The machine should be inspected, cleaned and lubricated at regular intervals, at least annually, by an approved TRACTEL UK repairer. Never use grease or oil containing graphite additives or molybdenum disulphide. To clean the machine, allow the machine to soak in a bath of some proprietary cleaning fluid, but not acetone and derivatives or ethylene trichloride and derivatives. Then shake the machine vigorously to loosen foreign matter and turn it upside down to allow the dirt to come out through the openings for the operating levers. Allow the mechanism to drain and become dry. After this treatment, ensure that the machine is well lubricated by applying a quantity of oil (type SAE 90-120) onto the internal mechanism through the openings for the operating levers, and for the models TU-8 and TU-16, through the special lubrication holes. To carry out this procedure, it is best for the machine to be not under load and in the released position. Alternatively operate the forward and reverse

Alternatively operate the forward and reverse

⚠ GENERAL WARNING ⚠

- 1- Before using the TIRFOR machine it is essential for the safe and correct operation of the equipment that this manual be read and fully understood and that all the instructions be followed. This manual should be made available to every operator. Extra copies of this manual will be supplied on request.
- 2- The TIRFOR machine allows the operator to carry out work with complete safety. Ensure that this machine is only handed over for use or rigging to an operator who is trained to operate it in a responsible manner.
- 3- Never use a machine which is not in good working condition. Replace any worn or damaged wire rope (See Section 10). Continuous monitoring of the condition of the machine, its wire rope and anchor sling is an important safety consideration.
- 4- The manufacturer declines any responsibility for the consequences of dismantling or altering the machine by any unauthorised person. Specially excluded is the replacement of original parts by parts of another manufacturer.
- 5- The models as described in this manual must not be used for lifting people.
- 6- Moreover, these models are designed for manual operation and must not be motorised. The TRACTEL Group has designed special motorised models (TU-16H and TU-32H).
- 7- Never attempt to overload the machine.
- 8- Standard TIRFOR machines are not designed for use in explosive atmospheres.
- 9- **IMPORTANT :** If the equipment described in this manual is supplied to an employed person, check that you meet your obligations with respect to safety at work regulations (see page 11 - Chapter 14).

LIFTING PEOPLE AND SPECIAL APPLICATIONS

TRACTEL UK markets a range of TIRFOR TUA machines (TU8A, TU16A, TU32A) specially designed for lifting people on suspended platforms. For further information on equipment for lifting people, and on any special application, please refer to TRACTEL UK.

TECHNICAL DATA

MODEL	TU-8	T-508D	TU-16	T-516D	TU-32	T-532D
Maximum working load	1	0.8	1.6			3.2
Weight : machine	8.4	6.6	18.0	13.5	27.0	24.0
telescopic operating handle standard 20 m of wire rope, complete kg	1.0	1.0	2.4	2.3	2.4	2.3
	6.1	6.1	13.1	13.1	26.6	26.6
Total weight of standard equipment kg	15.5	13.7	33.5	28.9	56.0	52.9
Machine dimensions :						
length	527	420	660	530	676	620
length with optional hook	-	550	-	650	860	840
height	265	250	330	315	330	355
width	108	99	140	127	156	130
telescopic handle : closed/extended cm	51/77	40/69	68/119	65/115	68/119	65/115
TIRFOR MAXIFLEX wire rope diameter	8.3	8.3	11.5	11.5	16.3	16.3
guaranteed breaking strain* kg	4000	4000	8000	8000	16000	16000
weight per meter	0.250	0.250	0.500	0.500	1.00	1.00
Rope travel (forward/reverse)** mm	70/76	46/63	56/70	42/57	30/48	18/36

* Including end fittings of the wire rope
 ** One complete cycle of the operating lever at maximum working load.

1. DESCRIPTION OF EQUIPMENT

The TIRFOR machine is a hand-operated lifting and pulling machine. It is versatile, portable and multi-purpose, not only for pulling and lifting but also for lowering, tensioning and guying.

The originality of the TIRFOR machine is the principle of operation directly on the wire rope which passes through the mechanism rather than being reeled onto a drum of a hoist or conventional winch. The pull is applied by means of two pairs of self-energised jaws which exert a grip on the wire rope in proportion to the load being lifted or pulled. A telescopic operating lever fitted to either the forward or the reverse lever transmits the effort to the jaw mechanism to give forward or reverse movement of the wire rope.

The machine is fitted with a hook or anchor pin, depending on the model, so that it can be secured quickly to any suitable anchor point.

TIRFOR machines, intended for lifting and pulling materials, are available in two ranges each with three models of different capacities:

- T-500D range for light duty applications (with safety release catch)

- TU range for heavy duty applications (with safety release catch).

Each machine is supplied with a telescopic operating handle, and usually with a 20m standard length of special TIRFOR MAXIFLEX wire rope fitted with a safety hook and wound onto a metal reeler. Longer or shorter lengths of wire rope are available on request.

This manual together with a guarantee card are supplied with each machine, as well as the CE declaration of conformity.

IMPORTANT : TIRFOR MAXIFLEX wire rope has been specially designed to meet the particular requirements of the TIRFOR machine. The manufacturer does not guarantee the safe operation of machines used with wire rope other than TIRFOR MAXIFLEX wire rope.

2. RIGGING ARRANGEMENTS

Various ways of rigging are shown in Figs. 2.1, 2.2, 2.3 and 2.4. Figs. 4 and 5 show particular arrangements (one forbidden and the other recommended).

The machine may be anchored to a fixed point with the wire rope travelling towards the machine (Figs. 2.1, 2.2, 2.3), or travel along the wire rope, with the load, the wire rope itself anchored to a fixed point (Fig. 2.4).

In example 2.2, the maximum working load of the pulley and the anchor point should be equal to or greater than twice the load.

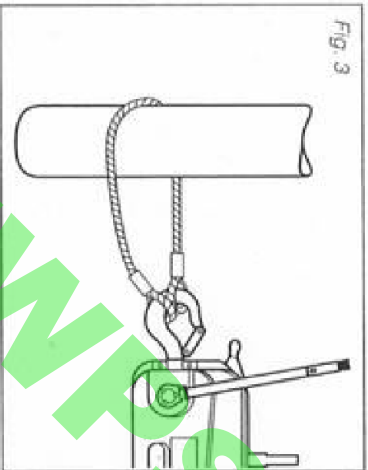
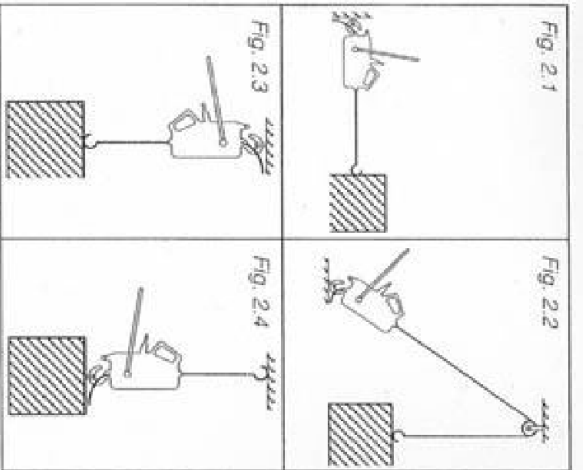

N.B. Whatever the rigging arrangement, and if the machine is anchored directly to a fixed point, ensure that there are no obstructions around the machine which could prevent the wire rope, the machine and anchor from operating in a straight line. It is therefore recommended to use a sling of an appropriate capacity between the anchor point and the machine (Fig. 3).

WARNING : Any rigging arrangement which requires the calculation of the forces applied should be checked by a competent engineer, with special attention to the appropriate strength of fixed point used.

For work such as guiding the trunk in tree felling, the operator should ensure that he is outside the danger area by passing the wire rope around one or more return pulleys.

8. SAFETY DEVICES

8.1 Overload limiting safety devices

All TIRFOR machines incorporate a shear pin system. In case of overload, one or more pins (depending on the model), fitted to the forward operating lever, shear and prevent further forward or lifting operations. Reverse operation is still possible to enable the load to be lowered or the wire rope to be slackened.

8.2 Rope release safety device

Models TU and T-500D are fitted with a two-handed - rope release system which requires deliberate operation by the user to release the machine. See section 4 - Releasing and engaging the jaws.

9. REPLACING THE SHEAR PINS

Figures 17, 18, 19 and 20 show the position of the shear pins for the various models. Spare shear pins are in the stub of the operating levers for models TU-8 and TU-16, and in the rope release lever for the other models, behind the plastic cap. Remove the sheared pins with a suitable punch.

For models TU-8 and TU-16, remove the forward operating handle stub by using an extractor. Remove the sheared pins. Refit the forward operating handle stub on the crank and align the grooves for the shear pins (Figs. 17 and 18).

For models T-500D and TU-32, align the holes of the upper and lower sections of the forward operating lever.

Position the spare shear pin(s) and drive it/them in with a hammer.

Warning : It is forbidden to replace sheared pins by anything other than genuine TIRFOR shear pins of the same model.

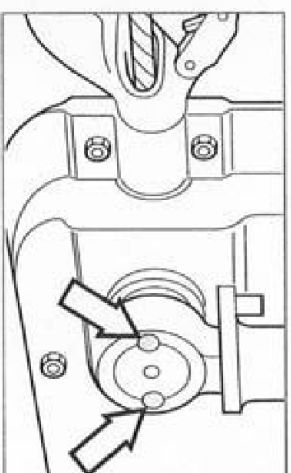
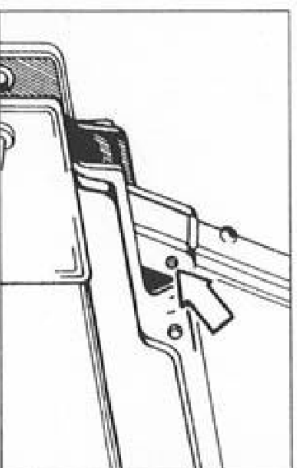
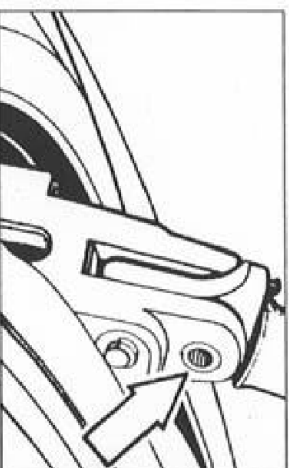
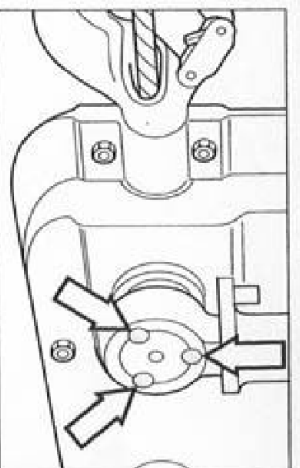

Before putting the machine back into operation, ensure that the cause of the overload is removed, if necessary, use multiple sheave blocks (See Fig 6).

Remember to re-order sheared pins and put them back in the correct place.

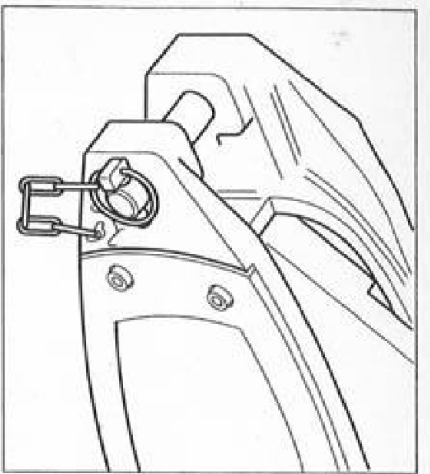

Fig. 13 - Anchor pin in position.

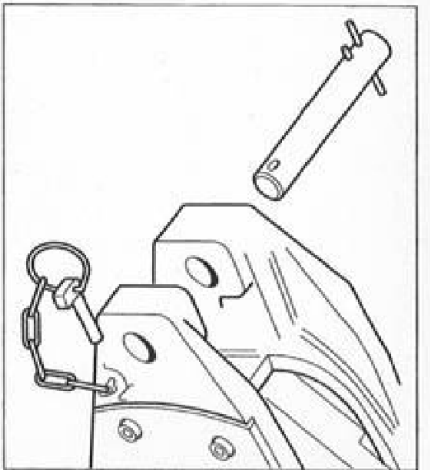

Fig. 14 - Anchor pin removed.

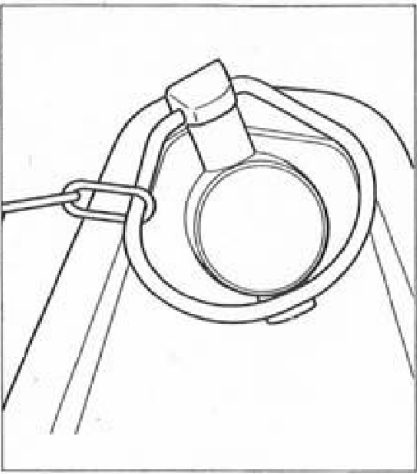

Fig. 15 - Spring clip closed.

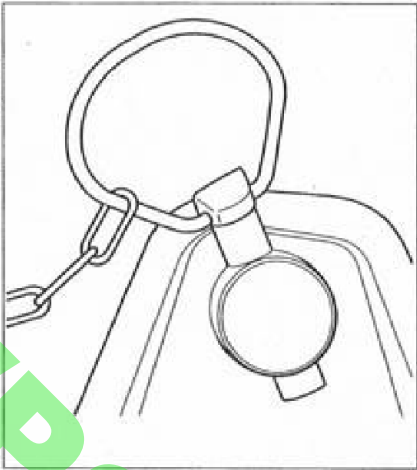

Fig. 16 - Spring clip open.

6. OPERATION

TIRFOR machines are very easy to use. Place the telescopic operating handle on either the forward or reverse operating lever, lock it into position by twisting, and move the operating handle to and fro. The operating arc is variable for ease of operation. When operation stops, both jaws automatically grip the wire rope and hold the load which is spread equally between the jaws.

The to-and-fro operation of the forward or reverse lever gives continuous movement of the load.

7. RELEASING THE WIRE ROPE AND STORAGE

It is essential to take the load off the machine before attempting to release the jaws. To do this, operate the reverse operating lever until there is no tension in the wire rope.

Remove the telescopic operating handle and return it to the closed position.

Release the machine and follow the instructions for installing the wire rope in the reverse order. Re-engage the jaws of the machine before putting it into storage.

Store the machine and wire rope in a dry place, away from the effects of the weather. The wire rope should be completely removed from the machine and rewound onto its reeler.

Before reeling the wire rope, it is recommended to inspect it, clean it with a brush and then grease it. (See section 10).

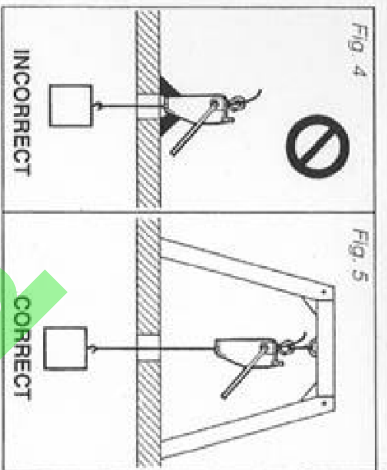

The capacity of the machine may be increased considerably for the same effort by the operator by using multiple sheave blocks. (See the examples set out in Figs. 6.1 and 6.2). The increase in the capacity shown is reduced depending on the efficiency of the pulleys.

The diameter of the pulleys used should be equal to at least 18 times the diameter of the wire rope. (Refer to the applicable regulations).

For any rigging arrangement other than those described in this manual, please consult TRACTEL S.A.S. or a competent specialist engineer before operating the machine.

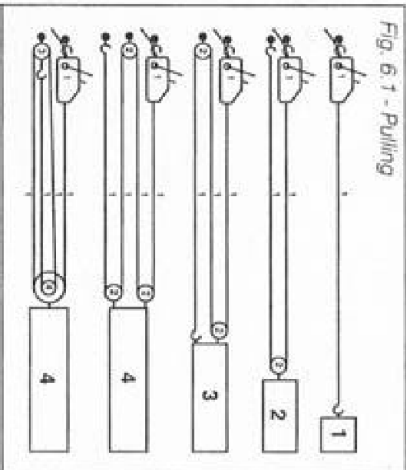
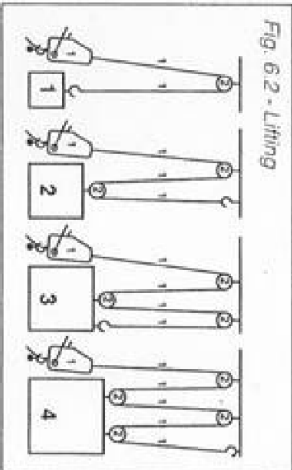

Fig. 6.2 - Lifting



3. INSTALLING THE WIRE ROPE

N.B. When handling the wire rope it is recommended to protect the hands by using work gloves.

If the wire rope is to be anchored to a high anchor point, the wire rope should be anchored before fitting the wire rope in the machine.

1. Uncoil the wire rope in a straight line to prevent loops or kinks.
2. Release the internal mechanism (See section 4: "Releasing and engaging the jaws.")
3. Insert the wire rope through the rope guide at the end opposite to the anchor point (hook or anchor pin).
4. Push the wire rope through the machine, and if necessary, helping it by operating the forward operating lever.

5. When the wire rope appears through the anchor point, pull the slack wire rope through the machine, to the point required.
6. Engage the jaws by operating the rope release mechanism (See section 4: "Releasing and engaging the jaws.")

7. Anchor the TIRFOR machine or the wire rope to the appropriate fixed point (See section 5: "Anchoring") taking care to ensure that the anchor point (hook or pin, depending on the model) is correctly fixed.
8. Extend the telescopic operating handle until the spring locks into position. If necessary, twist the two sections of the handle, one inside other, to align the spring (Fig. 1).

9. Replace the telescopic operating handle on the chosen operating lever (forward or reverse) and twist the handle to ensure that it is locked in position (about a half turn).

After this procedure, the machine is ready for operation, providing the load is correctly anchored to the machine or the wire rope (See section 5: "Anchoring" and section 2: "Rigging arrangements").

4. RELEASING AND CLOSING THE JAWS

Each machine is fitted with a lever (Fig. 1 item 4) for releasing the jaw mechanism which should only be operated when the machine is not under load.

There are two positions for the rope release lever (See Fig. 7, 8 and 9): released or engaged.

N.B. When not in operation, it is recommended that the rope release lever should be in the engaged position. The machine must therefore be released before attempting to feed in the wire rope.

4.1. TU-8 or TU-16 (Fig. 7)

Releasing :

1. Completely press the rope release safety catch (5) and lift the rope release lever (4).
2. Release the safety catch and continue to lift the rope release lever until it locks into position. The internal mechanism is in the released position.

Engaging :

1. Lift the rope release lever slightly.
2. Press and maintain pressure on the rope release safety catch, allowing the release lever to slowly travel back to its original position. Release the safety catch. The release lever locks in position under the effect of its spring.

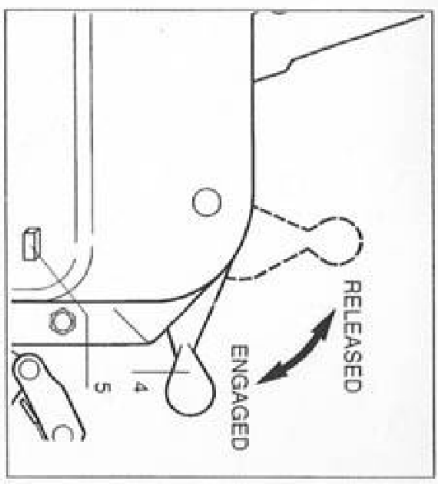

Fig. 7 - TU-8 and TU-16. Rope release lever.

4.2. TU-32 (Fig. 8)

Place the anchor point against a support.

Releasing :

1. Completely press rope release safety catch (5) and push the rope release lever (4) towards the anchor point.
2. Release the safety catch and continue to push the rope release lever until it locks into position. The internal mechanism is in the released position.

Engaging :

1. Push the rope release lever towards the anchor point.
2. Press and maintain pressure on the rope release safety catch, allowing the release lever to slowly travel back to its original position. Release the safety catch. The release lever locks in position under the effect of its spring.

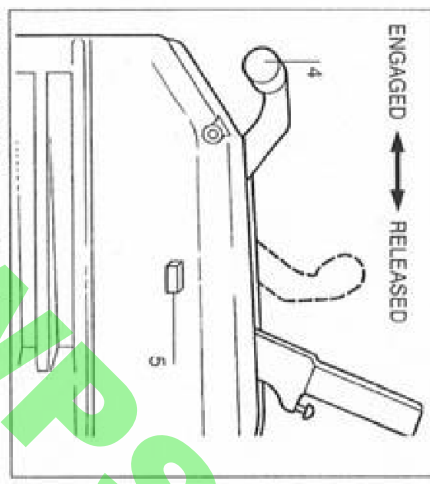

FIG. 8 - TU-32. Rope release lever.

4.3. T-500D range (Fig. 9)

Place the anchor point against a support.

Releasing :

Turn the rope release safety catch (5) and push the rope release lever (4) towards the anchor pin until it locks into position when raised slightly at its limit. Release the safety catch.

Engaging :

1. Turn the rope release safety catch
2. Press the rope release lever vertically downwards, allowing the lever to travel back to its original position under the effects of its spring. Release the safety catch.

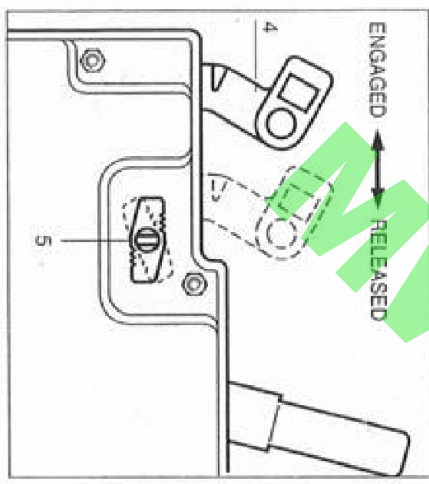

Fig. 9 - T500D range. Rope release lever

5. ANCHORING

Failure to anchor the TIRFOR machine correctly runs the risk of a serious accident. The user must always ensure before operation that the anchor point(s) for the machine and wire-rope are of sufficient strength to hold the load.

It is recommended that TIRFOR machines should be anchored to a fixed point or to the load using an appropriate capacity sling. It is forbidden to use the machine's wire rope as a sling by passing it around the load and hooking it back onto itself (Fig. 10 : incorrect anchoring arrangement; Fig. 10a : correct anchoring arrangement). The anchoring arrangement of models TU-8 and TU-16 is a hook fitted with a safety catch (Figs. 11 and 12). In all cases when anchoring the machine the safety catch of the anchor hook should be correctly closed. In its position at the tip of the hook (Fig. 12). This advice for the machine anchor hook also applies to the hook fitted to the wire rope.

TIRFOR machines TU-32 and T-500D are anchored by means of a removable anchor pin, fitted across the two ends of the side cases (Fig. 13 and 14) and locked in position by a spring clip (See Figs. 15 and 16).

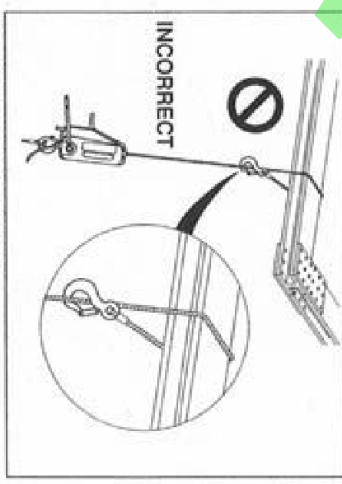

Fig. 10 - Incorrect slinging.



Fig. 11 - Machine anchor hook with catch in open position

Optional hooks are available to fit the anchor point of models T-500D and TU-32

To anchor using the anchor pin, follow the procedure below:

1. Open the spring clip of the anchor pin.
2. Remove the spring clip from the anchor pin.
3. Slide the anchor pin out of the side cases (Fig. 14).
4. Fit the anchoring arrangement, such as a sling, between the side cases.
5. Refit the anchor pin through the side cases and anchoring arrangement, such as the eyes of a sling.
6. Refit the spring clip to the anchor pin.
7. Close the spring clip, ensuring that it fits correctly over the end of the anchor pin and cannot fall out.

Warning : It is essential for the safe operation of the machine to ensure that, before loading the machine, the anchor points, hooks or pins, are correctly secured, (with the safety catch correctly located on the hook - Fig. 12).

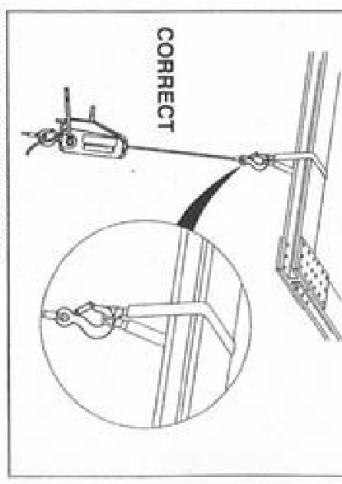
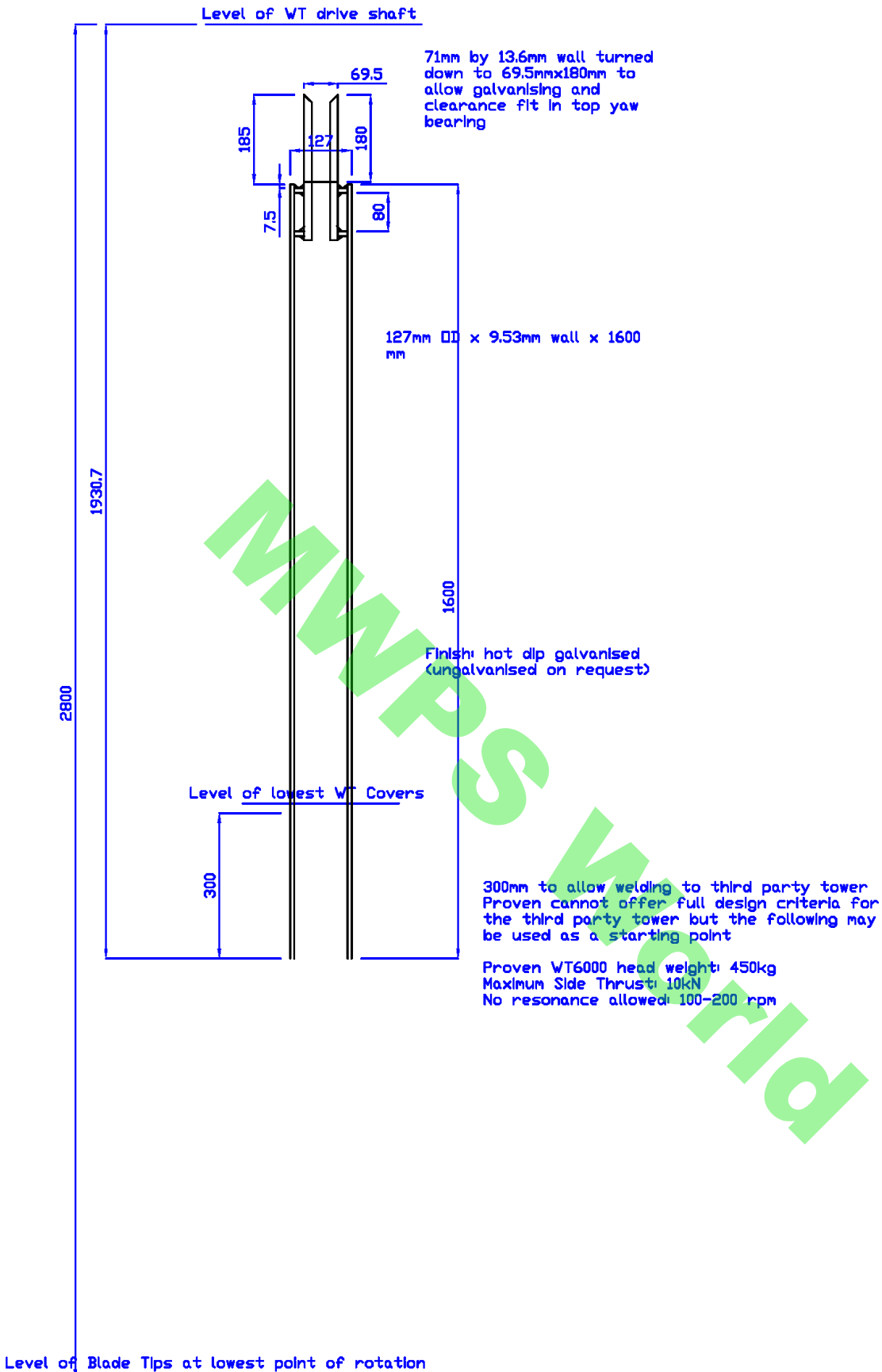



Fig. 10a - Correct slinging.



Fig. 12 - Machine anchor hook with catch in closed position



ZONE	REV	DESCRIPTION	REVISIONS	DATE	APPROVED					
	-	-		-	-	 <p>© Proven Energy Ltd, Wardhead Park, Stewarton, Ayrshire, KA3 5LH, UK, Tel +44 (0) 1560 485 570 Info@provenenergy.com All rights reserved</p> <p>Proven TM160 Tower Mount for the WT6000 turbine for use with masts by others</p>				
	-	-		-	-					
	-	-		-	-					
						PREPARED BY BR	FSCM NO.	DWG NO. 6000 MI 006 rev4.dwg	REV 4	
						CHECKED BY	SCALE	Date 25/10/03	SHEET	



WT6000 MANUAL

OPERATION & MAINTENANCE

PROVEN WT6000 WIND TURBINE WITH TM1500/TM900 SELF-SUPPORTING TOWER



OPERATION

BRAKE

The wind turbine has a brake for safety during raising and lowering, maintenance and in case of emergency.

To apply the brake – open tower access door; turn brake lever fully up; pull brake rope down and place loop over pin lever; pull lever down and “under centre” until it meets back plate and stops the rotor.

RUNNING

The wind turbine can be left to run in any wind. It is not necessary to keep a load on the wind turbine since the self regulating blades will control speed without load.

N.B. Extended unnecessary periods of running off-load should be avoided where possible.

When working on the output cables or systems ALWAYS stop the wind turbine AND switch off MCB in controller before proceeding.

NOTE

When running unloaded the generator will give up to double the full load output voltage – so always treat the output with caution, even on low voltage models.

MAINTENANCE

After 3 months;

1. Lower wind turbine and check all fittings for tightness.
2. Grease main rotor bearings and yaw bearing housing.
3. Check base plate fittings are tight.

Yearly – as above plus the following;

1. Check brake pad thickness is more than 2mm.
2. Check brake operation before raising wind turbine.
3. Check for general wear and tear and replace any worn parts.
4. Pay particular attention to the blades, especially the blade root. A damaged or cracked blade should be repaired or replaced immediately.
5. If the wind turbine is operating in particularly arduous conditions (e.g. severe turbulence etc.) then check fittings and wear more often.

PROVEN WT6000 WIND TURBINE WITH TM1500/TM900 SELF-SUPPORTING TOWER



RAISE/LOWER USING TIRFOR WINCH

RAISING

- Check hinge pin is in position and split ends at both ends.
- Assemble two piece gin pole and attach one end to attachment points at base of mast and other end to mid pole bracket located 2.5m up from base of mast.
- Check gin pole nuts/bolts are tight.
- Hook Tirfor wire rope to mid pole bracket. Hook Tirfor to winch anchor and feed wire rope through Tirfor as per Tirfor instructions.
- Check that power cables will not be trapped under wind turbine base when lifted.
- Apply wind turbine brake.

CLEAR LIFTING AREA OF ALL NON-ESSENTIAL PERSONNEL. DO NOT ALLOW ANYONE TO BE IN THE VICINITY OF THE WIND TURBINE WHILST RAISING.

- Pull wind turbine up slowly and smoothly with the Tirfor winch, following Tirfor instructions at all times.
- When upright, keep tension on rope, until all base bolts are in and tight. When base bolts are tight, release rope. Dismantle gin pole and winch and remove from lifting area.
- Release wind turbine brake and remove brake cord from brake lever.
- If breezy, check rotation of wind turbine.

LOWERING

- Apply wind turbine brake and place trestle to support lowered wind turbine.
- Fit gin pole and winch as for raising.
- Check all shackles, bolts and fittings are secure before lowering.
- Take up slack in Tirfor winch/rope and put handle in lowering position.
- Make sure hinge pin and split pins are in position.

CLEAR LIFTING AREA OF ALL NON-ESSENTIAL PERSONNEL. DO NOT ALLOW ANYONE TO BE IN THE VICINITY OF THE WIND TURBINE WHILST LOWERING.

- Remove tower bolts.
- Pay out a little rope and lift end of gin pole to tilt wind turbine over balance point until strain comes on Tirfor.
- Lower turbine by operating Tirfor slowly and smoothly.

PROVEN ENERGY LTD

Wardhead Park

Stewarton

Ayrshire

KA3 5LH

SCOTLAND

Tel: +44 (0)1560 485 570

Fax: +44 (0)1560 485 580

Email: info@provenenergy.com

Web: www.provenenergy.com



Proven Wind Turbine Maintenance Schedule

Frequency of recommended checks

TASK	TYPE OF SERVICE CHECK			
	INITIAL 3 MONTH	QUARTERLY	ANNUAL	10 YEAR
check for smooth running	✓	✓	✓	✓
check tower bolts	✓	✓	✓	✓
check base plate j-bolt nuts	✓	✓	✓	✓
check brake operation*	✓	-	✓	✓
check blades	✓	-	✓	✓
check zebedee springs	✓	-	✓	✓
polish slip rings	-	-	✓	✓
check slip ring brushes	-	-	✓	✓
grease shaft bearings	-	-	✓	✓
grease upper yaw bearing	-	-	✓	✓
check lower yaw bearing	-	-	✓	✓
check covers	-	-	✓	✓
check welds	-	-	✓	✓
blade change	-	-	-	✓
zebedee spring change	-	-	-	✓

* brake assembly is optional on WT600 model

Battery Inverter System Care



Maintenance Task	Importance & Frequency	Remarks
Check and top up battery electrolyte level	HIGH Typically between 2 (light use) and 12 (heavy use) times per year	Essential for normal battery operation that the electrolyte level does not fall below the top of the plates (visible via watering hole on top of the battery cells). In soft water areas use ordinary tap water (avoid peaty water). In hard water areas use de-ionised water available from battery suppliers. Do not use mineral water as this often comes from hard water areas.
Perform equalize charge	HIGH Once per month	An equalize charge is a charge to a higher voltage than normal with two main benefits. The main purpose is to <i>equalize</i> voltage in all the battery cells so that they do not fight against each other. In addition any small areas of sulphation on the battery plates are removed restoring the full capacity of the battery. For instructions on how to set an equalize charge on the TRACE SW inverters see accompanying sheet. Don't equalize the battery if electrolyte levels are already low since an equalize charge uses a bit of battery electrolyte – top up first.
Check battery intercell connections and inverter connections	HIGH Typically 2 times per year	When dealing with high currents like those in a battery inverter system a bad connection can cause sparking or arcing or even a battery fire. CARE SHOULD BE TAKEN WHEN WORKING WITH METAL TOOLS on battery connections. Proven recommend the use of <i>safety glasses, gloves and a terminal shroud</i> so that only one terminal can be accessed by metal tools at a time. Overtightening battery terminals does not help – terminals are made of soft metal (usually lead) which will <i>creep</i> with time. Clean dirty connections with wire brush to ensure good electrical contact.
Keep clean & dry	MEDIUM	Muck or dampness on the surface of the battery cells can eventually create a discharge path between the +/- terminals – clean with a dry rag.
Insulate battery if required	MEDIUM	A battery operating at a temperature of 5°C has only about half its rated Amphours (usually measured at 25°C). A battery working (charging or discharging) creates a small amount of internal heat so insulation is not always required. If the battery is to be kept in a cold location then consider insulating it with wood/foam box BUT CONSULT PROVEN FOR DETAILS OF THE REQUIRED VENTING

IMPORTANT – Avoid leaving your battery in a low state of charge for long periods as this can damage it.

SETTING EQ CHARGE on the TRACE SW Series



It is easy to set an equalize charge with the SW TRACE inverter.

PRESS THE GREEN BUTTON ONCE

this gives you access to the SET GENERATOR menu which should look like this

Set Generator OFF <u>AUTO</u> ON EQ
--

The underline shows that the inverter will automatically bring in the diesel generator when a low battery voltage condition is detected.

PRESS THE SET POINT (RIGHT) BUTTON TWICE

The LCD display should now look like this

Set Generator OFF AUTO ON <u>EQ</u>
--

The diesel will not start immediately – but the next time the diesel is started it will perform a higher voltage charge to equalize all the individual cell voltages. After the EQ charge has been completed use the same method to return to AUTO.

TIP

If the Set Generator Menu is initially OFF OR it was on AUTO and you want to start the equalize charge immediately then you can fool the TRACE by

- 1) changing the Set Generator Menu to EQ as above
- 2) changing the LBCO setting (menu 9, screen 2) to a voltage higher than present battery voltage. Note that menus 9 and above are normally hidden. Press the RED and GREEN buttons simultaneously to get access to the “advanced” menus.
- 3) If it was on AUTO the diesel should start after 30 seconds or it was OFF then manually start the diesel (remember to turn it off again after a few hours!)
- 4) Remember to return LBCO to its original setting – you can do this as soon as the diesel has started.

TIP

Note that the time (default 2 hours) for an equalize charge can be varied – for batteries in bad condition an extended equalize charge may be a good idea. Consult the TRACE manual.



PROVEN WIND TURBINES
WIND TURBINE SPARES PRICE LIST JANUARY 05

<i>Product Code</i>	<i>Description</i>	<i>List Price</i>
WT600 Zebedee Springs		
ZB601	1 set WT600 Zebedee Springs (3 off)	£ 110
ZB602	1 WT600 Zebedee Spring	£ 40
WT600 Blades		
BL601	1 set WT600 blades (3 off) including blade clamps, hub blade clamp, back spring and all fixings for each blade	£ 260
BL602	1 WT600 blade including blade clamps, hub blade clamp, back spring and all fixings for each blade	£ 97
BL603	1 set WT600 blades (3 off) (to be used with previous fixings)	£ 150
BL604	1 WT600 blade (to be used with previous fixings)	£ 56
Generator WT600		
GW601	Windings of generator for WT600	£ 415
GP601	1 set generator magnet plates (2 off) for WT600	£ 430
GP602	1 generator magnet plate for WT600	£ 235
WT2500 Zebedee Springs		
ZBD2501	1 set WT2500 Zebedee Springs (6 off) (includes fixings)	£ 175
ZB2502	1 WT2500 Zebedee Spring (includes fixings)	£ 45
WT2500 Blades		
PU2501	1 set of WT2500 blades (3 off) with long life PU hinge including 2 blade clamps, hub blade clamp and fixings	£ 415
PU2503	1 set of 3 long life PU hinges for use with previous WT2500 blades. Includes instructions	£ 195
BL2501	1 set WT2500 blades (3 off) including 2 blade clamps, hub blade clamp, back spring and all fixings for each blade.	£ 290
BL2502	1 WT2500 blade including 2 blade clamps, hub blade clamp, back spring and all fixings.	£ 107
BL2503	1 set WT2500 blades (3 off) (to be used with previous fixings)	£ 180
BL2504	1 WT2500 blade (to be used with previous fixings)	£ 66
BSP2501	1 set of WT2500 back springs (3 off)	£ 36
Upgrade Kits		
WUK2201	Spring Upgrade Kit for the WT2200. After fitting, the new longer springs as used with the WT2500, may be used (ZB2501)	£ 50
Generator WT2500		
GW2501	Windings of generator for WT2500	£ 759
GP2501	1 set generator magnet plates (2 off) for WT2500	£ 785
GP2502	1 generator magnet plate for WT2500	£ 432
WT2500 Yaw Rubbers		
LYR2501	1 Set (of 4) of lower yaw rubbers for the WT2500. Supplied without fixing bolts unless requested. NOTE: Grease should be applied on internal surface of the yaw rubber where it contacts the bolt but not on the outer surface where it contacts the mast	£ 5
WT6000 Zebedee Springs		
ZB6001	1 set WT6000 Zebedee Springs (9 off)	£ 395
ZB6002	1 WT6000 Zebedee Spring	£ 55
ZBL6001	1 set WT6000 Zebedee Springs (15 off) with tapered spring ends	£ 725
ZBL6002	1 WT6000 Zebedee Spring with tapered spring ends	£ 55
WT6000 Blades		
BL6001	1 set WT6000 blades (3 off) including blade clamps, hub blade clamp, back spring and all fixings for each blade.	£ 1,655
Generator WT6000		
GW6001	Windings of generator for WT6000	£ 1,620
GP6001	1 set generator magnet plates (2 off) for WT6000	£ 1,670
GP6002	1 generator magnet plate for WT6000	£ 920

NOTE: All prices exclude VAT and Carriage

UK Warranty



Products by Proven Energy Ltd are carefully designed, manufactured, tested and inspected. In consequence we undertake to replace any part found to be defective in material or workmanship free of charge for a period of two years from delivery to the end user. ***This warranty covers only those products manufactured by Proven Energy Limited.***

General Conditions:

This warranty does not cover damage to Proven Energy Products resulting from unauthorised alteration or modification, accident, misuse, improper installation, operation or maintenance or failure to conduct periodic inspections and maintenance. Proven Energy Limited reserves the right to repair or replace the defective component(s) at their sole option. Proven Energy Limited does not accept any additional liability for defects from reasonable wear and tear.

Use of Proven Wind Turbines with Mast or Towers manufactured by others:

Poor mast design may cause vibration both in the mast and the nacelle of the wind turbine. Faults arising from poor mast design shall be classed as improper installation. Mast should be designed to avoid resonance within the operating frequency range of the wind turbine. The onus shall lie with the owner to show their mast has not caused the fault.

Shipping and Transport Costs:

Warranty repairs will be made at the premises of Proven Authorised Representatives or our factory. The end user must return the defective component(s) properly packed, and with all freight and insurance charges prepaid. All freight, shipping and insurance costs including duties, taxes and import charges incurred in returning Proven Energy Products are to be met by end user.

Disclaimer:

Proven Energy Limited shall not be liable for any incidental or consequential damages resulting from the proper or improper use, for any purpose whatsoever, of Proven Energy Products.

Statutory rights:

This warranty in no way diminishes the end user's statutory or legal rights.

Actions in the Event of a Defect Occurring During Warranty Period

In the unlikely event of a defect arising, **first ensure the safety of people and equipment by electrical disconnection and application of the wind turbine brake, as appropriate.** Please notify the Proven Service Department, or the Proven Authorised Representative immediately who will advise on the correct procedure.

Minor Faults:

If the fault is a minor one and can be rectified by replacing components which could be simply fitted by the end user or a local fitter, then a replacement part will be sent as soon as possible by post or courier.

Serious Faults:

In the unlikely event of a serious fault, Proven Energy Limited or a Proven Authorised Representative will arrange for an engineer to attend the, if required, and rectify the fault. The work will be charged at standard rates if the conditions of the Proven Warranty as set out above do not apply.

Warranty on other Products Supplied by Proven Energy Limited:

Proven Energy Limited will arrange for the goods to be promptly returned to the manufacturer for repair or replacement as applicable.

Export (Outside UK) Warranty



Proven Energy Products are carefully designed, manufactured, tested and inspected. In consequence we undertake to replace any part found to be defective in material or workmanship free of charge for a period of two years from delivery to the end user. **This warranty covers only those products manufactured by Proven Energy Limited.**

General Conditions:

This warranty does not cover damage to Proven Energy Products resulting from unauthorised alteration or modification, accident, misuse, improper installation, operation or maintenance or failure to conduct periodic inspections and maintenance. Proven Energy Limited reserves the right to repair or replace the defective component(s) at their sole option. Proven Energy Limited does not accept any additional liability for defects from reasonable wear and tear.

Use of Proven Wind Turbines with Mast or Towers manufactured by others:

Poor mast design may cause vibration both in the mast and the nacelle of the wind turbine. Faults arising from poor mast design shall be classed as improper installation (see General Conditions). Mast should be designed to avoid resonance within the operating frequency range of the wind turbine. The onus shall lie with the owner to show their mast has not caused the fault.

Shipping and Transport Costs:

Warranty repairs will be made at the premises of Proven Authorised Representatives or our factory. The end user must return the defective component(s) properly packed, and with all freight and insurance charges prepaid. All freight, shipping and insurance costs including duties, frees, taxes and import charges incurred in returning Proven Energy Products are to be met by end user.

Disclaimer:

Proven Energy Limited shall not be liable for any incidental or consequential damages resulting from the proper or improper use, for any purpose whatsoever, of Proven Energy Products.

Statutory rights:

This warranty in no way diminishes the end user's statutory or legal rights.

Actions in the Event of a Defect Occurring During Warranty Period

In the unlikely event of a defect arising, **first ensure the safety of people and equipment by electrical disconnection and application of the wind turbine brake, as appropriate.** Please notify the Proven Service Department, or the Proven Authorised Representative immediately who will advise on the correct procedure.

Minor Faults:

If the fault is a minor one and can be rectified by replacing components which could be simply fitted by the end user or a local fitter, then a replacement part will be sent as soon as possible by post or courier. For some locations, it will be the customer's responsibility to arrange transport of these parts from our Stewarton factory site.

Serious Faults:

In the unlikely event of a serious fault, the turbine should be packed in sturdy export crate and shipped to our Stewarton factory. All shipping charges shall be responsibility of the customer. An appraisal will then be carried out to determine whether works required are covered under warranty and customer advised. Any works required which are not covered under Proven Warranty will be charged at standard rate.

Warranty on other products supplied by (but not manufactured by) Proven Energy Limited will be followed in accordance with the manufacture recommendation.



WT6000 MANUAL

FOUNDATION INSTRUCTIONS



Foundation Pack for WT6000/TM900

PACKING LIST

- 1 - GALVANISED BASE PLATE
- 6 – M30 FOUNDATION RODS, WITH 12 M30 NUTS AND 6 M30 WASHERS
- 9 - M24 HIGH TENSILE BOLTS AND 9 WASHERS
- 1 - ANCHOR PIN
- 1 set Foundation Pack
 - 1 Pack Description (this page)
 - 1 Standard foundation diagram
 - 1 Anchor foundation diagram
 - 1 Alignment/Access diagram
 - 1 Foundation description (incl. concrete mixing details)

N.B. REINFORCING STEEL MESH SHEET IS ALSO REQUIRED FOR THE FOUNDATION WORK BUT IS NOT INCLUDED IN THE KIT SUPPLIED BY PROVEN

FOUNDATION PREPARATIONS

The main foundation consists of a large block of high-strength concrete. Six lengths of M30 screwed rod are set into the concrete and are attached to the Foundation Base Plate. The Base Plate includes the hinge-pin attachment, which is used to raise and lower the turbine (see diagrams). Preferably, the concrete should be prepared and the foundation prepared with one load of concrete. Where this is not possible, the top layer should be added before the bottom one has had time to set.

Don't 'Shutter & Backfill'

When preparing house foundations a mould is prepared into which the concrete is poured. Earth/rocks are then filled around the foundation after the concrete has set.

For WT foundations it is better to have an irregular shaped foundation than to have a perfect cube and then surround it with loose earth - just dig a hole and then fill it! This will produce a foundation with good stability.

Preparing the Base Foundation

The base foundation consists of 6m³ of strong-mix concrete. Normally this is prepared as a rough 2.5 x 2.5 x 1m cube, but where ground conditions dictate, a shallower wider foundation of the same volume may be used. As and when required soil analysis can be conducted to identify exactly what type and dimension of foundations are to be used in certain ground-types. Proven Energy Ltd. can provide basic information to give an idea as to what is required, however professional advice should be sought when an exact soil analysis is required.

Screw the 9 large (M24) bolts supplied with the base-plate it to their full extent (not transported this way to protect the end thread). The ends of the bolts are factory greased. These bolts will later be withdrawn and used to bolt the WT tower to the base plate. Inserting them at this stage makes sure there is the necessary clearance in the concrete.

Attach the M30 screwed rod with nuts provided to the base plate before pouring concrete. Insert reinforcing mesh into hole and jack up base plate assembly to approximately the right height. **It is very important that one of the M30 screwed rods at the hinge side of the base plate is set low into the concrete so that there will be access for the hinge pin to slide in later. If this is not done when the concrete is laid then the screwed rod should be hacksawed off just above the nut afterwards.** Insert conduit or soil pipe used for wind turbine power cable from edge of hole up through centre of base plate. Add concrete (Readimix supplier is usually easiest for this type of volume) and use vibrating concrete poker as necessary to remove air bubbles.

Important

Before setting the Base Plate and foundations into the concrete foundation consider which way your WT will be lowered/raised and position the hinge-pin accordingly

Use a spirit level and the nuts on the screwed rod to get the base plate flat. **It is vital that underneath the base plate is completely filled with concrete. The base plate must be fully supported by concrete when installation of turbine and tower takes place.** Leave the final tightening of the M30 nuts until the hardening period is over.

Clean the base plate of any excess concrete.

Winch Anchor Foundation

Refer to foundation diagrams for positioning. The anchor consists of a 1m cube or equivalent. It should be located on the opposite side of the base plate to the hinge pin attachment. **N.B. It is important that the anchor is placed exactly in line with the centre of the base plate and perpendicular to the line of the hinge brackets.** The pull on the anchor point for the WT6000/TM900 during raising and lowering is approximately 2500kg.

Concrete Specification

If using a Readimix supplier, ask for 35 Newton concrete. If mixing the concrete yourself, you should use the following proportions by volume

1:2:4
cement:sand:gravel

Approximate volumes and weights for a 1m³ foundation are

Cement:	310kg or 6.2 bags	(1 bag = 50kg)
Sand:	0.43m ³	(967 kg or approx 1.0 tonnes)
Gravel:	0.86m ³	(2150kg or approx 2.2 tonnes)

Hardening Time

You should allow plenty of time for the foundation to set and **harden** fully before erecting the turbine. We recommend a hardening period of approximately 2 weeks. For this reason, foundations are normally prepared in advance of the main installation. Note that the hardening time may be lengthened by poor weather conditions and shortened by the use of a quick-setting concrete additive.

Poor Foundation Preparations

Proven reserve the right to cancel an installation of a turbine if it is thought the foundations are of a poor quality. Subsequent costs in repairing the foundation and any further site visits will be met by the customer.

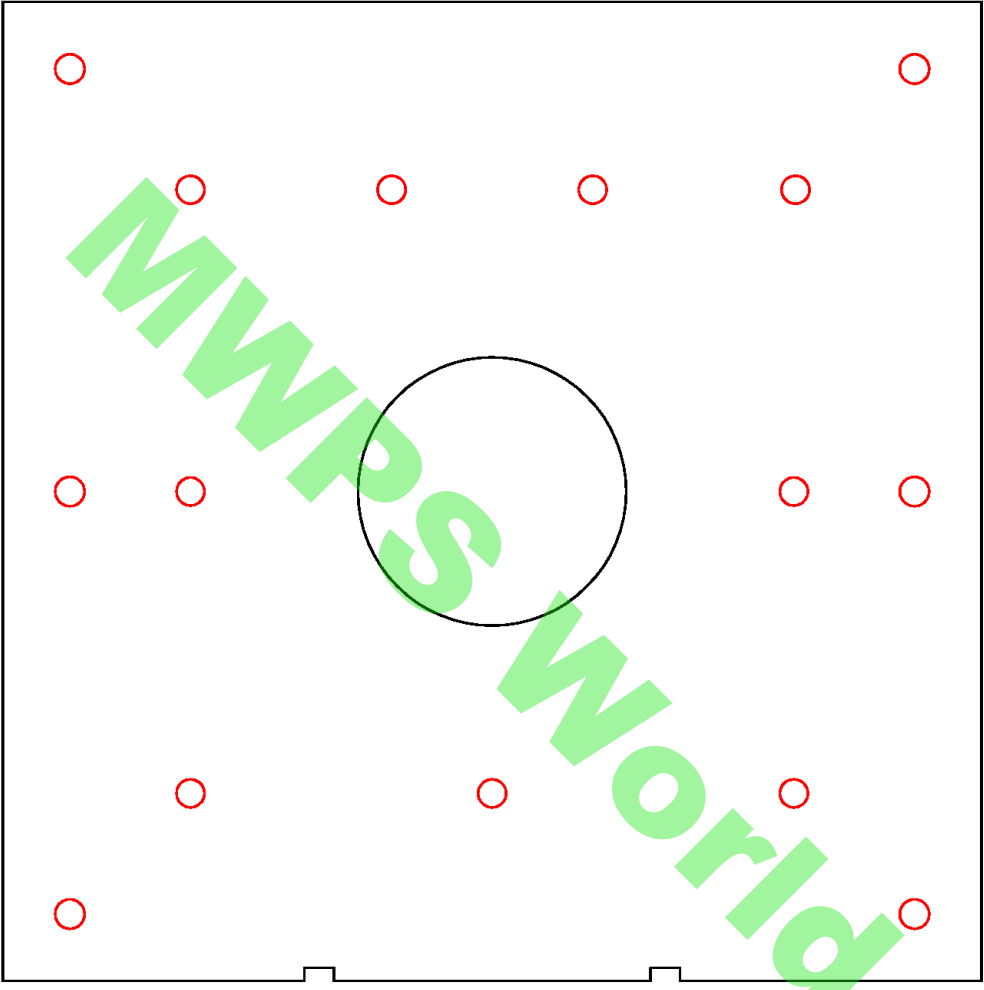

ZONE	REV	DESCRIPTION	REVISIONS	DATE	APPROVED
-	-	-	-	-	-
-	-	-	-	-	-
-	-	-	-	-	-

PREPARED BY RC		CHECKED BY	
FSCM NO.	DWG NO.	SCALE	DATE
	8000 FO 027.dwg		09/08/03
SHEET sheet		REV	1

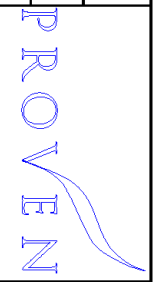

© Proven Energy Ltd, Wathead Park
 Sowerton, KX3 5LH, UK, Tel: +44 1560 485 570
 info@provenenergy.com All rights reserved

Drawing Title WT8000/TM800 Baseplate Drawing



Foundation Pack for WT6000/TM1500

PACKING LIST

- 1 - GALVANISED STEEL BASE PLATE
- 15 - M30 FOUNDATION RODS WITH EXTENSION BOSSES FITTED
- 10 – M30x100 HIGH TENSILE BOLTS AND 10 WASHERS
- 10 – SPACER TUBE PIECES FOR INITIAL USE WITH M30X100 HT BOLTS
(25mm IN LENGTH)
- 5 – M30x60 HIGH TENSILE BOLTS AND 5 WASHERS
- 1 – 30 mm DIAMETER ANCHOR ROD / PIN & PLATE
- 1 set Foundation Pack
 - 1 Pack Description (this page)
 - 1 Standard foundation diagram
 - 1 Anchor foundation diagram
 - 1 Alignment/Access diagram
 - 1 Foundation description (incl. concrete mixing details)

N.B. REINFORCING STEEL MESH SHEET IS ALSO REQUIRED FOR THE FOUNDATION WORK BUT IS NOT INCLUDED IN THE KIT SUPPLIED BY PROVEN

FOUNDATION PREPARATIONS

The main foundation consists of a large block of high-strength concrete. Fifteen M30 foundation rods are set into the concrete and are attached to the Foundation Base Plate. The Base Plate includes the hinge-pin attachment, which is used to raise and lower the turbine (see diagrams). Preferably, the concrete should be prepared and the foundation prepared with one load of concrete. Where this is not possible, the top layer should be added before the bottom one has had time to set.

Important

Before setting the Base Plate and foundations into the concrete foundation consider which way your WT will be lowered/raised and position the hinge-pin accordingly

Don't 'Shutter & Backfill'

When preparing house foundations a mould is prepared into which the concrete is poured. Earth/rocks are then filled around the foundation after the concrete has set.

For WT foundations it is better to have an irregular shaped foundation than to have a perfect cube and then surround it with loose earth - just dig a hole and then fill it! This will produce a foundation with good stability.

Preparing the Base Foundation

The base foundation consists of 10m³ of strong-mix concrete. Normally this is prepared as a rough 3 x 3 x 1.2m cube, but where ground conditions dictate, a shallower wider foundation of the same volume may be used. As and when required soil analysis can be conducted to identify exactly what type and dimension of foundations are to be used in certain ground-types. Proven Energy Ltd. can provide basic information to give an idea as to what is required, however professional advice should be sought when an exact soil analysis is required.

Screw the 10 M30x100mm bolts into the foundation rod extension bosses through the 10 holes in a circular pattern in the middle of the base plate. These bolts will later be withdrawn and used to bolt the WT tower to the base plate, once concrete has cured. It is therefore necessary to place a 25mm spacer tube under the head of each bolt. (Please refer to diagram). Tighten bolts till the bosses are tight against the underside of the base plate.

Through the remaining 5 holes on the outer edge of the plate screw the 5 M30x60mm bolts into the foundation rod extension bosses, again till the bosses are tight against the underside of the base plate. No spacers are required for the outer 5 bolts.

Insert reinforcing mesh into hole and suspend foundation rod/base plate assembly into the hole **making sure that base plate is completely level**. Insert conduit or soil pipe used for wind turbine power cable from edge of hole up through centre of base plate. Add concrete (Readimix supplier is usually easiest for this type of volume) and use vibrating concrete poker as necessary to remove air bubbles. **Make sure that base plate is fully supported underneath by concrete**.

Clean the base plate of any excess concrete.

Winch Anchor Foundation

Refer to foundation diagrams for positioning. The anchor consists of a 1.5m x 1.5m x 1m cube or equivalent. It should be located on the opposite side of the base plate to the hinge pin attachment. **N.B. It is important that the anchor is placed exactly in line with the centre of the base plate and perpendicular to the line of the hinge brackets.** The pull on the anchor point for the WT6000/TM1500 during raising and lowering is approximately 2500kg.

Concrete Specification

If using a Readimix supplier, ask for 35 Newton concrete. If mixing the concrete yourself, you should use the following proportions by volume

1:2:4
cement:sand:gravel

Approximate volumes and weights for a 1m³ foundation are

Cement:	310kg or 6.2 bags	(1 bag = 50kg)
Sand:	0.43m ³	(967 kg or approx 1.0 tonnes)
Gravel:	0.86m ³	(2150kg or approx 2.2 tonnes)

Hardening Time

You should allow plenty of time for the foundation to set and harden fully before erecting the turbine. We recommend a hardening period of approximately 2 weeks. For this reason, foundations are normally prepared in advance of the main installation. Note that the hardening time may be lengthened by poor weather conditions and shortened by the use of a quick-setting concrete additive.

M30 x 60 High Tensile Base Bolts,
5 Bolts around the outside
of the foundation plate.

M30 x 100 High Tensile Base Bolts,
10 Bolts with a PCD of 584mm
These bolts secure the tower
to the foundation plate.

15mm Thick Foundation BasePlate

Threaded Bosses

Plastic Pipe for cable duct
cast into concrete.

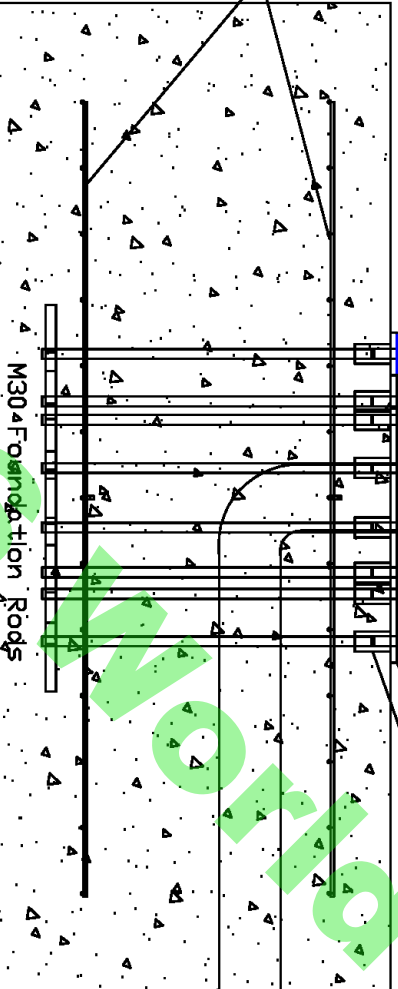

CONCRETE
35 NEWTON OR
BETTER

M30 Foundation Rods

Hole 3 Metres Square
By 1.2 Metres Deep

WT6000 15m Proven Mast
Foundation Baseplate

10 OFF DRILLED HOLES CLEARANCE
CLEARANCE FOR M30 BASE BOLTS
(32mm DIAMETER) PCD 584mm

5 OFF DRILLED HOLES
FOR M30 FOUNDATION
RODS: (32mm DIAMETER)

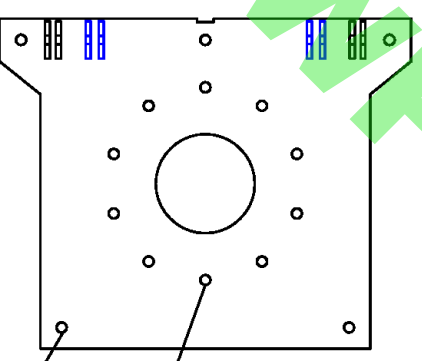

Two layers of reinforcing mesh
6mm or heavier A142 grade with
approx 200mm sq holes,
Mesh should be 28m square.

ZONE	REV	DESCRIPTION	REVISIONS	DATE	APPROVED	PREPARED BY	PH	CHECKED BY	RC	FSM NO.	DWG NO.	REV	SCALE	DATE	SHEET	N/A
	1	MODIFICATION TO SHOW NEW BOSS ARRANGEMENT		15/01/03	-											
	2	MODIFICATION TO SHOW NEW SHAPE AND LUGS		15/01/04	-											
	3	MODIFICATION - REMOVAL OF 3 OUTSIDE HOLES		04/04/05	-											

<p>© Proven Energy Ltd, Worfield Park, Sturwinton Ayrshire, KA3 5LH, UK, Tel +44 1560 485 570 info@provenenergy.com All rights reserved</p>										<p>Drawing Title 6kW 15m TOWER FOUNDATION DIAGRAM</p>	
---	--	--	--	--	--	--	--	--	--	---	--

WWW.PROVENENERGY.COM

Anchor Block Layout For WT6000 with TM1500 Mast

Secure winch attachment plate once concrete has cured.

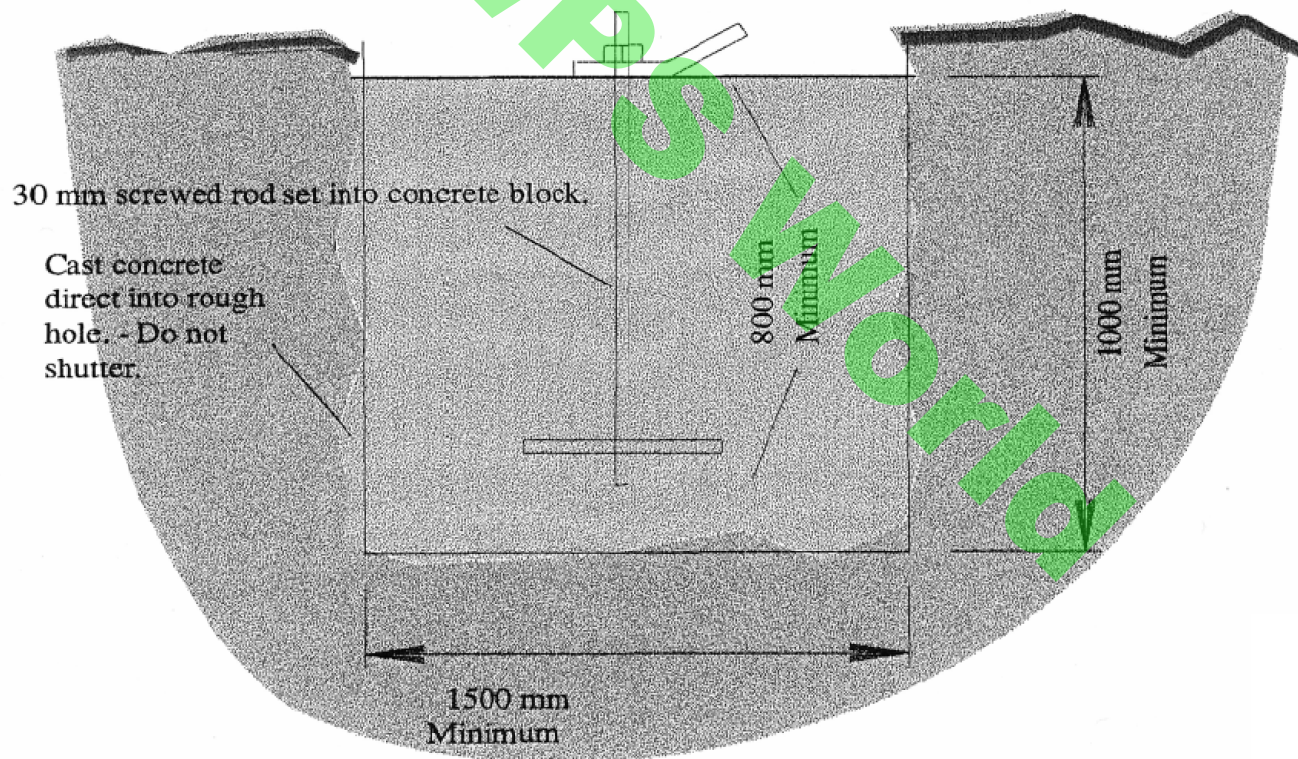

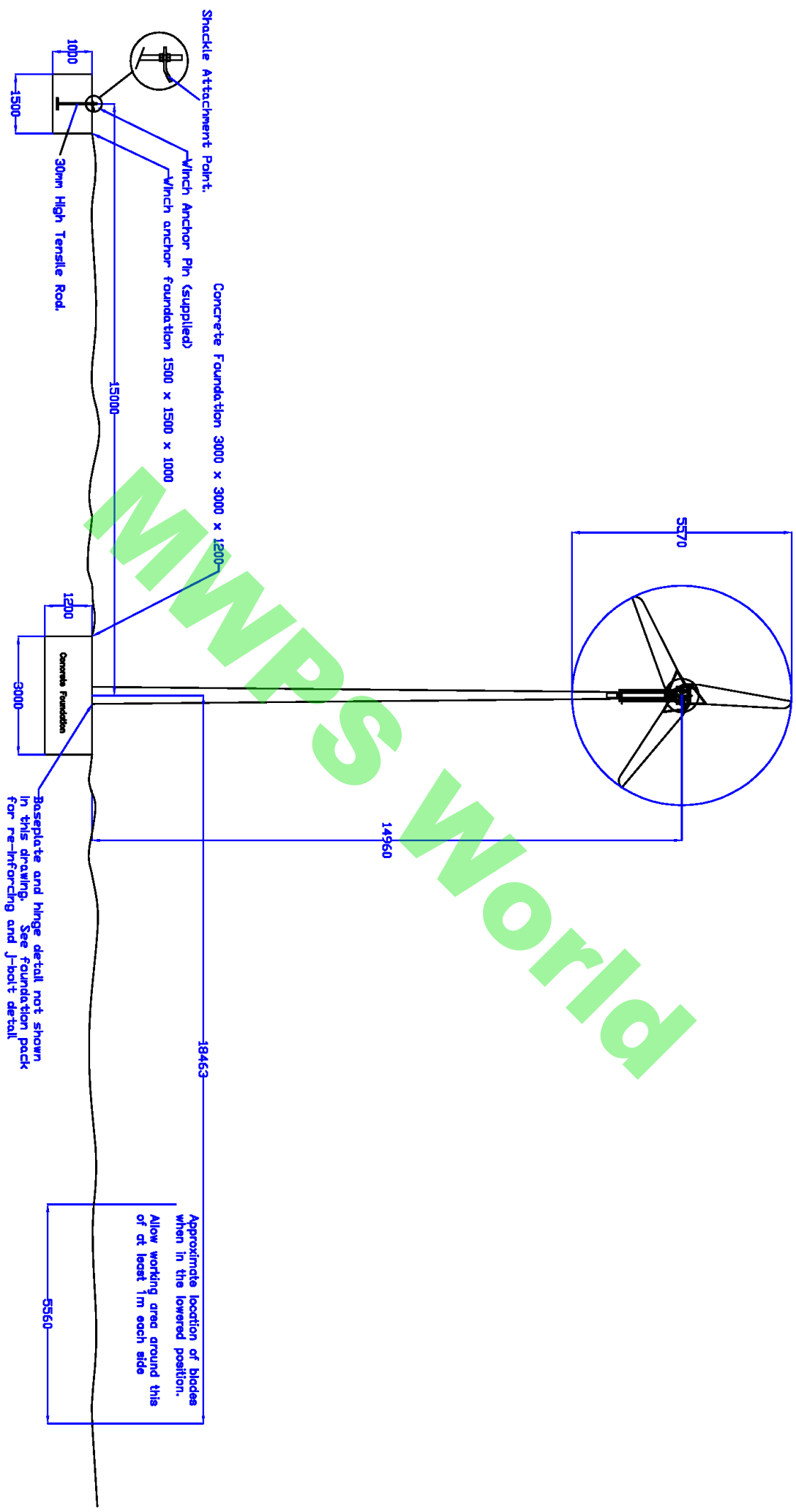

ZONE	REV	DESCRIPTION	REVISIONS	DATE	APPROVED	PREPARED BY BR	CHECKED BY	REV
2	-	Converted to M/dims changed		5/3/02	BR	FSCM NO.	DWG NO.	REV
	-					8000 FO 017 rev 3.dwg		3
	-					DATE REV OCT '03	SHEET 1	



© Proven Energy Ltd, Warden Park, Stewarton, Ayrshire, KA5 5LH, UK, Tel: +44 (0) 1580 485 570
 info@provenenergy.com All rights reserved

WT6000 Wind Turbine with TM15000 Tilt up Tower