

Industrial  
Hydraulics

Electric Drives  
and Controls

Linear Motion and  
Assembly Technologies

Pneumatics

Service  
Automation

Mobile  
Hydraulics

**Rexroth**  
Bosch Group

# Innovative Gearboxes for Wind Turbines



The Drive & Control Company



## Completely new wind turbine gearbox

Brand: Bosch Rexroth

Type: GPV 510D

Output: 2500 kW

Rotor d: 90m

Original factory price is: 430.000 eur.

BOSCH REXROTH  
GPV 510D Gearbox



BOSCH REXROTH  
GPV 510D Gearbox

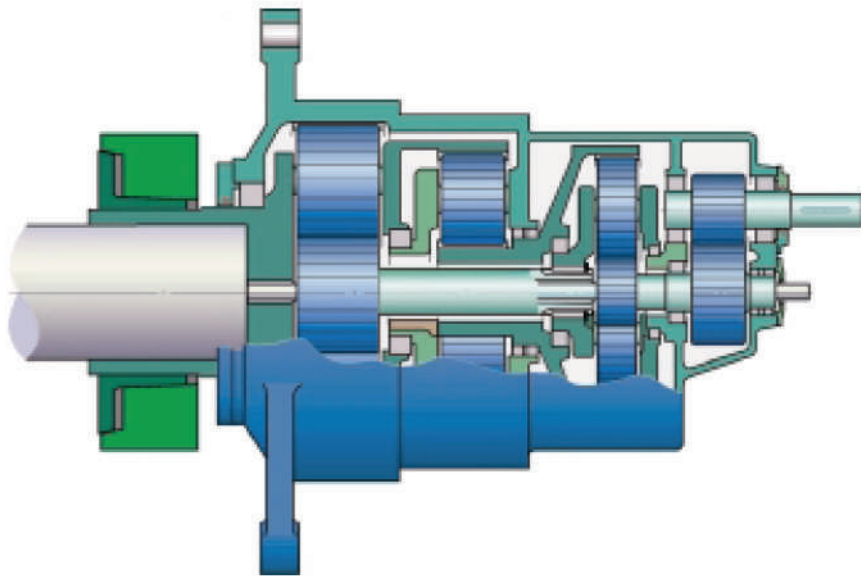

Generator Power	2500 kW
Rotor Diameter	90 m
Input Torque	1700 kNm
Transmission Ratio	72:1
Gearbox Weight	19000 kg

#### Tradition and Competence

Today our company can boast more than 100 years' experience in drive technology. Our know-how, combined with the market position and the technological competence of Rexroth, makes us a desirable partner for wind turbine manufacturers.

Rexroth supplies all gearbox types used in wind turbines: generator, yaw, and pitch gearboxes.

From the very beginning, we have played a major role in the development of wind energy technology.

In the early nineties, for example, we designed the main drives for the 3.2 megawatt AEOLUS power plants. Wind turbines of that series, named after the Greek god of winds, are still in use today, for instance in the "Jadewindpark" at Wilhelmshaven, Germany. Although the smaller plants of today operate more economically, the giant

AEOLUS power plants remain an impressive pioneering example.

So far they have produced more kilowatt-hours than any other type of wind turbine in the world.

#### Long-term Reliability

Erecting a wind turbine means investing in the future. For comparison: While a car is designed for 2,000 operating hours, a wind turbine with a life of 20 years may clock up as many as 175,000 operating hours. That's why it pays to make the best choice for each component.

Our know-how in engineering, production and testing protects you from unfavourable downtimes. Before a component is manufactured, its 3D design has undergone extensive virtual testing. The result is an optimized component.

The standards we set ourselves are imposed also on our subsuppliers.

We use exclusively high-quality materials from reputable manufacturers and we convert and machine them using the most modern equipment. For example, the internal helical gearings of the ring gears nitrogen-hardened in our heat treatment shop are also ground in-house. Perfect control of all production processes makes sure that we achieve the high product quality that our customers expect from us.



AEOLUS-turbine – since 1993 operating reliably with Rexroth gearboxes

## Wind force is our forte

Erect a wind turbine and yield energy – that's the expectation of any wind farm operator. The longer a plant runs trouble-free, the higher the energy yield and the return on investment will be. High-quality components from Rexroth are an essential prerequisite for achieving this goal.



Rexroth gearbox under full-load test in test bench

Continuous improvement in gearbox technology is part of Rexroth's business philosophy. Thus our company pioneered hardened and ground gear teeth as well as the use of planetary gearboxes for general engineering applications. Our constant dialog with leading universities and reputable manufacturers of antifriction bearings contributes to the continuous improvement of our products. The result is reliability achieved through steady further development of proven

technologies in combination with a meticulous quality management. We have five test benches on which we conduct full-load tests for main drives with rated powers of up to 5 megawatts as well as specific tests as requested by customers. We run for instance accelerated lifetime tests to analyze gearbox service lives. We also have vast experience in measuring various conditions of prototype gearboxes installed in actual wind turbine drive trains:

Using our own measuring instruments, we take field readings, such as air-borne and structure-borne sound readings and torque- and load measurements, as part of our design and development validations.

## Our Lead Your Advantage

The wind energy industry is undergoing rapid development towards more powerful ratings. The turbines built today have rated powers of up to 5 megawatts and are equipped with gearboxes from Rexroth – for a reason.

Offshore wind farm Horns Rev –  
80 turbines with Rexroth gearboxes

Higher wind turbine capacity means larger rotor diameters and higher input torques for gearboxes at the rotor shaft. The gearboxes must be more efficient without adding unacceptable weight. What is important here is finding the optimum power-to-weight ratio. Compact planetary gearboxes from Rexroth offer a remarkable power density. With our patented power flow distribution concept we can offer you a future-oriented drive solution.

We develop tailor-made solutions for any turbine: At the engineering stage, we work in partnership with our customers' engineers. In other words: customer-specific engineering is a discipline in which we excel. The reasons for our competence are evident – several decades of experience in planetary gearbox technology and great innovative power.



## We Have your Wish for Tranquility at Heart

The available space for wind turbines is getting scarcer with each new turbine built. Today wind turbines are set up even in the vicinity of residential areas. Low-noise operation is therefore a subject of ever greater importance. For this reason, noise optimization of our gearboxes is one of our constant concerns.



For noise optimization, gearboxes are designed on the basis of the customer's plant-specific performance curves. The demand for low-noise gearboxes is not new to us. Even more than 30 years ago, we manufactured large-size gearboxes for cruise ships. What then helped passengers sleep tight, contributes today to the quiet running of generator gearboxes. The secret of their low noise level lies not

only in our engineering approach, but also in the fact that we preferably machine our gearwheels using profile grinding techniques and – on a general level – in our constant dialog with scientists, conducted with a view to finding technologies that may improve the noise characteristics of our gearboxes.



## We are there for you around the Globe

The Rexroth sales network covers 86 countries. In addition, we have our own sales offices and service points in 36 countries worldwide. Thus qualified partners are available to you and your customers at virtually any place around the globe.



Maintenance and repair work is performed by skilled and experienced service engineers. We have vast experience in failure diagnosis, for which we use for instance structure-borne sound measuring technology, which provides instantly precise analysis results. In the major wind energy markets, such as Germany, the USA, Denmark, Spain and Italy, we maintain local service centers, where you can obtain spares of the same quality and production standard as the original parts.

Our services are not limited to repair and maintenance, but include also upgrading of existing plants. Upon request, we can provide upgrading kits for your particular needs, specified in cooperation with the Rexroth engineering and development departments.





## Overview of our Wind Turbine Gearboxes

We supplied the first generator gearboxes to the wind energy industry in 1985 – for wind turbines with a rated power of only 36 kilowatts. Today we are equipping multi-megawatt plants. With each technology jump, the efficiency of gearboxes becomes ever more important, as gearboxes are a significant factor in the economic viability of wind turbines. Below we provide details of the gearboxes used in wind turbines, all of which are available from Rexroth.

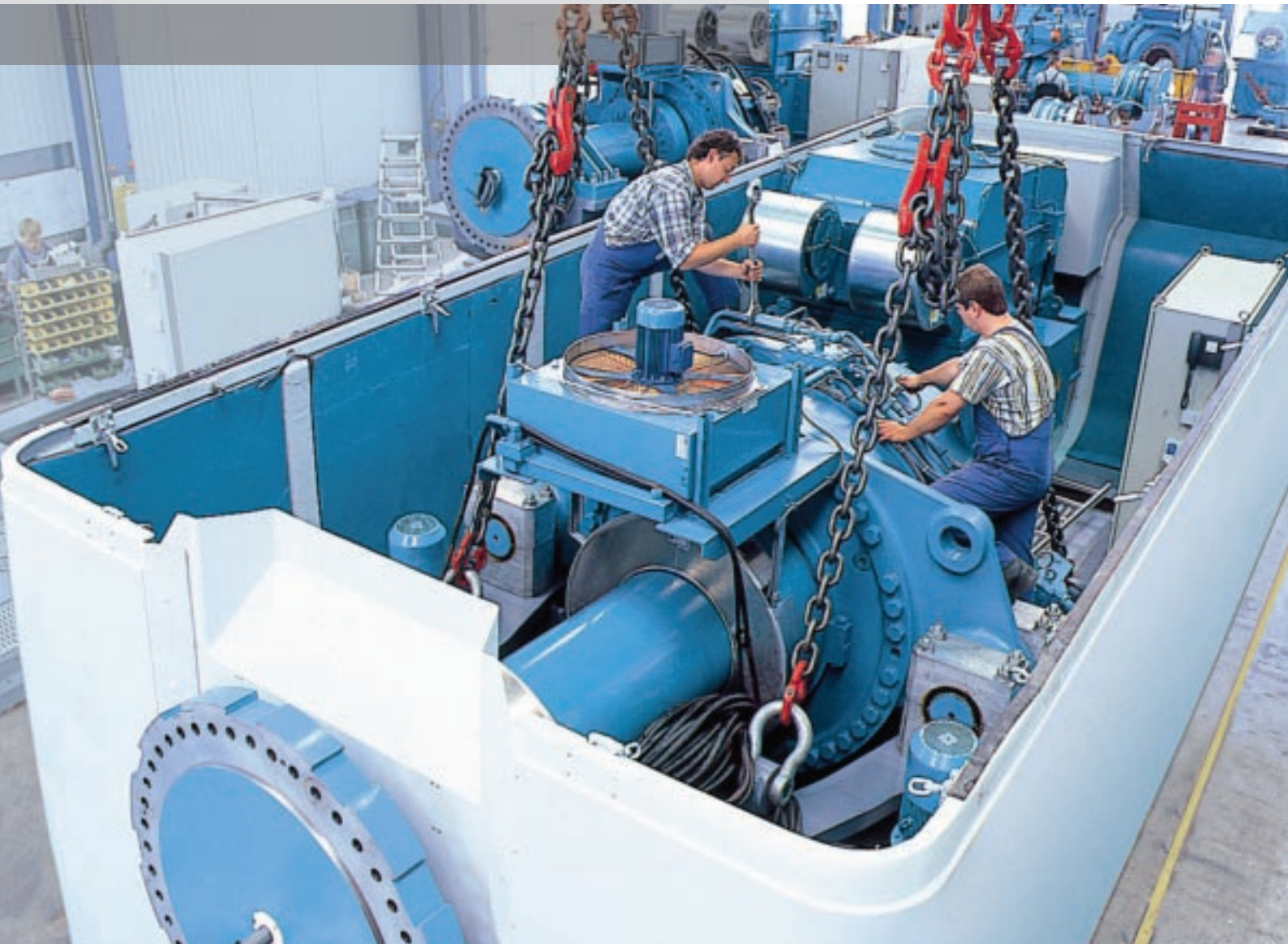



### Generator Gearboxes

Generator gearboxes serve to increase the rotor speed to the rotational speed required by generators to produce electricity. To date we have supplied well over 5,000 generator gearboxes to the five largest turbine manufacturers. Most of these gearboxes consisted of planetary and helical gear stages, designed to provide optimum transmission ratios.

### Gearbox Types Supplied

Gearbox Type/ Size	Generator Power [kW]	Rotor-Diameter [m]	Input Torque [kNm]	Transmission Ratio	Gearbox Weight [kg]
GPC 210	300	32	86	34 : 1	2,080
GPV 300	660	47	215	53 : 1	3,850
GPV 306	850	58	350	62 : 1	4,500
GPV 400	1,650	66	865	79 : 1	11,500
GPV 401	1,750	66	865	79 : 1	11,500
GPV 420	1,500	72	910	70/87 : 1	13,800
GPV 441	2,000	80	1,260	92/100/111/120 : 1	14,500
GPV 451	1,500	77	790	73/89/98 : 1	13,900
GPV 510D	2,500	90	1,700	72 : 1	19,000
GPW 545*	3,100	80	1,550	73 : 1	42,000

\* Supplied in 1993 for AEOLUS Wind turbines

### Technical Characteristics: Generator Gearboxes

Shafts and planetary gears are exclusively carried in high-quality antifriction bearings from reputable manufacturers. The helical gearing of the sun- and planetary wheels is case-hardened and ground, that of the ring gears is ground and nitrogenhardened.

Gear meshes and bearings are supplied with oil by a circular lubrication system. Most of the components of the oil supply system, i.e. tubes and manifolds, are accommodated inside the gearbox. There are connections for measuring instruments and sensors so that all relevant functions and operating conditions can be monitored.



#### Yaw Gearboxes

Planetary gearboxes for mobile and stationary equipment have been part of our range of products since 1968. In the eighties, starting from this technology, we developed the so-called yaw gearboxes which serve to properly turn the nacelles of wind turbines in the prevailing wind direction.

The accuracy of this alignment has a vital impact on the loads to which the components are subjected and on the overall efficiency of the turbine. To ensure that this operation is carried out with the greatest possible precision, the MOBILFLEX GFB yaw gearboxes are equipped with four planetary gear stages, which, together, provide a high gear ratio. This enables the nacelle to be aligned very accurately. However, the high overall weight calls for high torques, which can be effected by arranging several gear units around the yaw bearing. Thus, two to eight gear units may operate simultaneously in one nacelle.

#### Gearboxes Supplied

Gearbox Type/ Size	Static Output Torque [Nm]	Transmission Ratio [-]	Weight [kg]
GFB 024	25,000	1,428 : 1	150
GFB 036	31,000	800 : 1	230
GFB 060	76,000	1,235 : 1	330
GFB 080	89,000	1,151 : 1	590
GFB 110	110,000	915 : 1	670



#### Pitch Gearboxes

The efficiency of a wind turbine is not least dependent on its pitch drives. They act on the root of each of the rotor blades and turn them into the right position, because the blade pitch needs to be varied with the wind force for optimum efficiency. Due to the limited space available, these drives need to be very compact.

Our planetary gearbox design meets this requirement in an ideal manner. Depending on the given space, the drive problem can also be solved through the use of a bevel gear stage. Pitch gearboxes turn constantly with the rotor. Therefore they need to satisfy particular requirements in terms of sealing and lubrication.

#### Gearboxes Supplied

Gearbox Type/ Size	Static Output Torque [Nm]	Transmission Ratio [-]	Weight [kg]
GFB 002	3,000	60 : 1	54
GFB 009	7,500	149 : 1	100
GFB 017	14,000	106 : 1	160
GFB 024	25,000	122 : 1	200

#### Technical Characteristics: Pitch and Yaw Gearboxes

The teeth of the planetary gears are case-hardened and ground, as is standard at Rexroth. The gearboxes are splash-lubricated to ensure that all gear meshes and bearings are sufficiently supplied with oil. High-quality materials for all components in combination with high-precision machining by state-of-the-art machine tools, guarantees optimum quality.

### Generator Gearboxes of the Future

Higher generator outputs call for new gearbox concepts. The weights of the single components on the tower must not increase excessively. This requirement is of particular importance for offshore wind farms.

Rexroth has taken out a patent for an innovative gearbox concept, which makes the gearbox significantly lighter than conventional designs, thus contributing to reducing the weight of the tower head without jeopardizing current component safety standards.

This weight reduction is achieved by means of a judiciously designed power flow distribution system. Moreover, none of the gearbox components exceeds a defined weight limit, thus ensuring that all maintenance and installation work can be performed inside the nacelle. This saves time and money.

This concept is not tied to a particular power class - a novelty for main drives. This example - which is only one among many - demonstrates that innovative Rexroth gearboxes contribute to advancing the use of wind energy. That's the aim to which we devote all our energy.

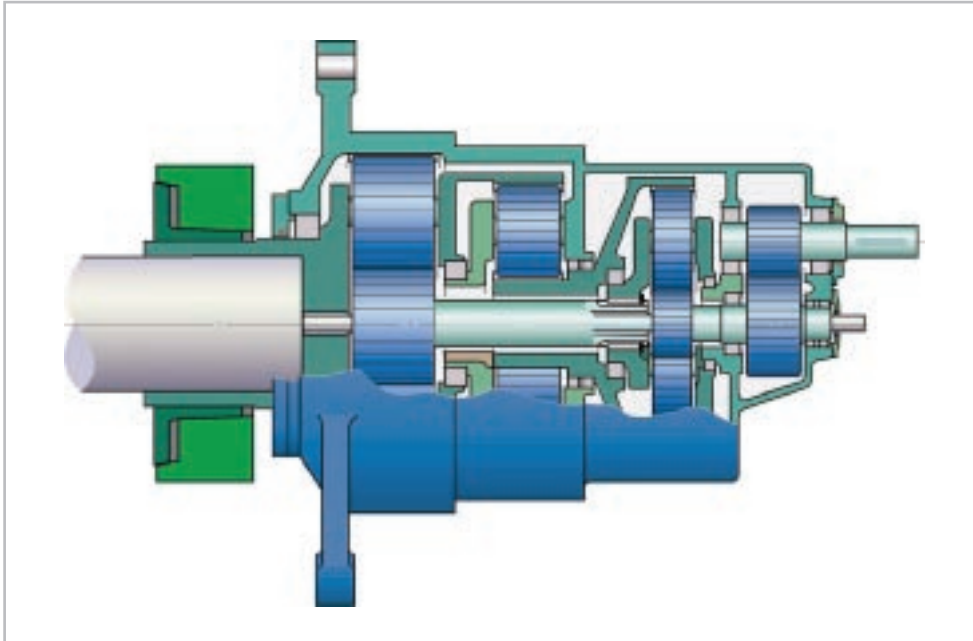

Plan of main gearbox with power flow distribution



# REFERENCES

## Nordex N100/2500

Power	
Rated power	2,500 kW
Rated wind speed	12,5 m/s
Cut-in wind speed	3.0 m/s
Cut-out wind speed	20.0 m/s
Rotor	
Diameter	100.0 m
Swept area	7,853.98 m <sup>2</sup>
Number of blades	3
Rotor speed	9.6 - 14.9 rpm
Type	NR 50, LM 48.8
Material	glas-fibre reinforced plastic
Manufacturer	Nordex, LM
Nacelle	
Design	separated
Gear box	
Type	combined spur / planetary gear, or differential gearbox
Stages	3
Ratio	1:77.4 (50 Hz) / 1:92.9 (60Hz)
Manufacturer	Eickhoff, BOSCH REXROTH
Generator	
Type	asynchronous, double fed induction, liquid-cooled
Number	1
Speed	740 - 1,300 rpm (50 Hz) / 890 - 1,560 rpm (60 Hz)
Voltage	660 V
Grid connection	via converter
Grid frequency	50 / 60 Hz
Manufacturer	Winergy, VEM, Elin
Control and Protection System	
Power limitation	pitch
Speed control	variable via microprocessor, active blade pitch control
Main brake	individual blade pitch control
Second brake system	disk brake
Yaw control system	4 electric gear motor(s)
Manufacturer of control system	
SCADA-System	
Technical details	
Power curve	on request
Sound power level	on request
Electrical characteristics	on request

<b>Tower 1</b>	
<b>Hub height</b>	100.0 m
<b>Type</b>	steel tubular
<b>Shape</b>	cylindrical, top segment conical
<b>Corrosion protection</b>	multi-coated
<b>Manufacturer</b>	divers
<b>Weight</b>	
<b>Single blade</b>	9.8 t
<b>Hub (incl. installed equipment)</b>	25.0 t
<b>Rotor (incl. hub)</b>	55.0 t
<b>Nacelle (without rotor &amp; hub)</b>	91.0 t
<b>Tower</b>	310.0 t
<b>Total weight</b>	456.0 t
<b>Type Approval</b>	
<b>Guideline, Class</b>	IEC IIIa, DIBt 2
<b>Survival wind speed</b>	52.5 m/s
<b>Tested (month/year)</b>	
<b>Reference energy yield</b>	
<b>kWh/a</b>	0.000.00
<b>Price</b>	
<b>Turbine (excl. VAT)</b>	
<b>Scope of Supply</b>	delivery, erection, remote data control
<b>Warranty</b>	9 years
<b>References (05/10/2009)</b>	
<b>Installed turbines worldwide</b>	1,013
<b>First installation in</b>	03/2008
<b>Special features</b>	
lightning protection system, ice sensor, condition monitoring system (CMS), Fire extinguishing system	
<b>Miscellaneous</b>	
Installations include N80 and N90.	

# GE 2.5xl

Power	
Rated power	2,500 kW
Rated wind speed	12.0 m/s
Cut-in wind speed	3.0 m/s
Cut-out wind speed	25.0 m/s
Rotor	
Diameter	100.0 m
Swept area	7,853.98 m <sup>2</sup>
Number of blades	3
Rotor speed	14.1 rpm (rated power)
Type	LM 487
Material	glas-fibre reinforced plastic
Manufacturer	
Nacelle	
Design	separated
Gear box	
Type	combined spur / planetary gear
Stages	3
Ratio	1:117.4
Manufacturer	BOSCH REXROTH
Generator	
Type	synchronous, permanent magnet
Number	1
Speed	1,650 rpm (rated speed)
Voltage	690 V
Grid connection	via converter
Grid frequency	50 / 60 Hz
Manufacturer	VEM
Control and Protection System	
Power limitation	pitch
Speed control	variable via microprocessor
Main brake	individual blade pitch control
Second brake system	disk brake
Yaw control system	4 electric gear motor(s)
Manufacturer of control system	
SCADA-System	
Technical details	
Power curve	yes
Sound power level	no
Electrical characteristics	no

	<b>Tower 1</b>	<b>Tower 2</b>	<b>ower 3</b>
<b>Hub height</b>	75.0 m	85.0 m	100.0 m
<b>Type</b>	steel tubular	steel tubular	steel tubular
<b>Shape</b>	conical	conical	conical
<b>Corrosion protection</b>	multi-coated m	ulti-coated	multi-coated
<b>Manufacturer</b>			
<b>Weight</b>			
<b>Single blade</b>			
<b>Hub (incl. installed equipment)</b>			
<b>Rotor (incl. hub)</b>			
<b>Nacelle (without rotor &amp; hub)</b>			
<b>Tower</b>			
<b>Total weight</b>			
<b>Type Approval</b>			
<b>Guideline, Class</b>	DIBt 2 D	IBt 2	DIBt 2
<b>Survival wind speed</b>			
<b>Tested (month/year)</b>			
<b>Reference energy yield</b>			
<b>kWh/a</b>	0.00 0	.00	0.00
<b>Price</b>			
<b>Turbine (excl. VAT)</b>			
<b>Scope of Supply</b>	delivery, erection, remote data control, maintenance	delivery, erection, remote data control, maintenance	delivery, erection, remote data control, maintenance
<b>Warranty</b>			
<b>References</b>			
<b>Installed turbines worldwide</b>	1		
<b>First installation in</b>	08/2006		
<b>Special features</b>			
WindRIDE-THRU® Anlagenbetriebssystem			
<b>Miscellaneous</b>			
- WindControl® Leistungsregelsystem - WindFREE® Reactive Power Blindleistungssystem - WindSCADA System - WindINERTIA Control - WindLAYOUT Service			



# Gamesa G80 - 2.0 MW

Power	
Rated power	2,000 kW
Rated wind speed	15.0 m/s
Cut-in wind speed	4.0 m/s
Cut-out wind speed	25.0 m/s
Rotor	
Diameter	80.0 m
Swept area	5,026.55 m <sup>2</sup>
Number of blades	3
Rotor speed	9.0 - 19.0 rpm
Type	
Material	glas-fibre reinforced plastic, epoxy resin
Manufacturer	Gamesa
Nacelle	
Design	separated
Gear box	
Type	combined spur / planetary gear
Stages	3
Ratio	1:100.5
Manufacturer	Echesa (Gamesa Group), Hansen, Bosch Rexroth, Winergy
Generator	
Type	asynchronous, double fed induction
Number	1
Speed	900 - 1,900 rpm
Voltage	690 V
Grid connection	via converter
Grid frequency	50 / 60 Hz
Manufacturer	Cantarey (Gamesa Group), ABB, Indar, VEM
Control and Protection System	
Power limitation	pitch
Speed control	variable via microprocessor, active blade pitch control
Main brake	individual blade pitch control
Second brake system	disk brake
Yaw control system	4 electric gear motor(s)
Manufacturer of control system	Gamesa, Ingeteam and ABB
SCADA-System	Gamesa WindNet® via fixed line, GSM or satellite
Technical details	
Power curve	<u>Detailed measurement results can be viewed in the catalog</u>
Sound power level	<u>Detailed measurement results can be viewed in the catalog</u>
Electrical characteristics	<u>Detailed measurement results can be viewed in the catalog</u>

	<b>Tower 1</b>	<b>Tower 2</b>	<b>Tower 3</b>	<b>Tower 4</b>
<b>Hub height</b>	60.0 m	67.0 m	78.0 m	100.0 m
<b>Type</b>	steel tubular	steel tubular	steel tubular	steel tubular
<b>Shape</b>	conical	conical	conical	conical
<b>Corrosion protection</b>	multi-coated m	ulti-coated m	ulti-coated m	ulti-coated
<b>Manufacturer</b>	Gamesa G	amesa	Gamesa G	amesa
<b>Weight</b>				
<b>Single blade</b>	6.5 t	6.5 t	6.5 t	6.5 t
<b>Hub (incl. installed equipment)</b>				
<b>Rotor (incl. hub)</b>	38.0 t	38.0 t	38.0 t	38.0 t
<b>Nacelle (without rotor &amp; hub)</b>	70.0 t	70.0 t	70.0 t	70.0 t
<b>Tower</b>	127.0 t	145.0 t	201.0 t	283.0 t
<b>Total weight</b>	235.0 t	253.0 t	309.0 t	391.0 t
<b>Type Approval</b>				
<b>Guideline, Class</b>	IEC Ia, + IEC IIa	IEC Ia, + IEC IIa	IEC Ia, + IEC IIa	IEC IIa
<b>Survival wind speed</b>	55.8 m/s	56.5 m/s	57.4 m/s	51.0 m/s
<b>Tested (month/year)</b>	05/2004 0	8/2004 0	8/2004 0	9/2003
<b>Reference energy yield</b>				
<b>kWh/a</b>	4,365,473.00 <sup>1)</sup>	4,516,988.00 <sup>1)</sup>	4,742,999.00 <sup>1)</sup>	5,099,713.00 <sup>1)</sup>
<b>Price</b>				
<b>Turbine (excl. VAT)</b>				
<b>Scope of Supply</b>	delivery, erection, remote data control, transformer	delivery, erection, remote data control, transformer	delivery, erection, remote data control, transformer	delivery, erection, remote data control, transformer
<b>Warranty</b>	2 years	2 years	2 years	2 years
<b>References (31/12/2008)</b>				
<b>Installed turbines worldwide</b>	603			
<b>First installation in</b>	2002			
<b>Special features</b>				
lightning protection system, , GL-certified condition monitoring system (CMS)				
<b>Miscellaneous</b>				
Extended warranty for 10 years upon request. Fault ride-through capability and regulation of active and reactive power.				

# REpower 5M

Power	
Rated power	5,075 kW
Rated wind speed	13.0 m/s
Cut-in wind speed	3.5 m/s
Cut-out wind speed	30.0 (onshore: 25.0) m/s
Rotor	
Diameter	126.0 m
Swept area	12,468.98 m <sup>2</sup>
Number of blades	3
Rotor speed	12.1 rpm (rated)
Type	
Material	glas-fibre reinforced plastic, Polyester
Manufacturer	LM Glasfiber AS
Nacelle	
Design	separated
Gear box	
Type	combined spur / planetary gear
Stages	3
Ratio	1:97
Manufacturer	Winergy BOSCH REXROTH
Generator	
Type	asynchronous, double fed induction
Number	1
Speed	750 - 1,170 rpm
Voltage	660 / 950 V
Grid connection	via converter
Grid frequency	50 Hz
Manufacturer	VEM
Control and Protection System	
Power limitation	pitch
Speed control	variable via microprocessor, active blade pitch control
Main brake	blade pitch control, individual blade pitch control
Second brake system	disk brake, blade pitch control, individual blade pitch control
Yaw control system	8 electric gear motor(s)
Manufacturer of control system	Bonfiglioli
SCADA-System	REguard Control B
Technical details	
Power curve	on request
Sound power level	on request

	<b>Tower 1</b>	<b>Tower 2</b>
<b>Hub height</b>	85.0 - 95.0 m	117.0 m
<b>Type</b>	steel tubular, Offshore hub height site specific	steel tubular, Onshore tower
<b>Shape</b>	cylindrical	cylindrical
<b>Corrosion protection</b>	multi-coated m	ulti-coated
<b>Manufacturer</b>	Ambau A	mbau
<b>Weight</b>		
<b>Single blade</b>	19.5 t	
<b>Hub (incl. installed equipment)</b>	71.0 t	
<b>Rotor (incl. hub)</b>	129.5 t	
<b>Nacelle (without rotor &amp; hub)</b>	315.0 t	
<b>Tower</b>	site specific t	
<b>Total weight</b>		
<b>Type Approval</b>		
<b>Guideline, Class</b>	IEC IIb, DIBt 3	DIBt 3
<b>Survival wind speed</b>	60.0 m/s	60.0 m/s
<b>Tested (month/year)</b>		
<b>Reference energy yield</b>		
<b>kWh/a</b>	0.00 0	.00
<b>Price</b>		
<b>Turbine (excl. VAT)</b>		
<b>Scope of Supply</b>	Lightning protection system, condition monitoring system (CMS), fire detection and extinguishing system	
<b>Warranty</b>		
<b>References (2009-11-20)</b>		
<b>Installed turbines worldwide</b>	23	
<b>First installation in</b>	10/2004	
<b>Special features</b>		
lightning protection system, ice sensor, condition monitoring system (CMS), (CMS) Fire detection and extinguishing system, oil particle counter		
<b>Miscellaneous</b>		
Offshore tower height is site-dependent with a hub height of 85.0 to 95.0 m. The 117.0 m onshore tower consists of four cylindrical and one conical segment. Offshore towers consist of one or two segments, which are either both cylindrical or cylindrical and conical (depending on the site and the required hub height and foundation).		

# Fuhrländer FL 2500-100

## Power

<b>Rated power</b>	2,500 kW
<b>Rated wind speed</b>	11.5 m/s
<b>Cut-in wind speed</b>	3.5 m/s
<b>Cut-out wind speed</b>	25.0 m/s

## Rotor

<b>Diameter</b>	100.0 m
<b>Swept area</b>	7,853.98 m <sup>2</sup>
<b>Number of blades</b>	3
<b>Rotor speed</b>	9.4 - 17.1 rpm
<b>Type</b>	LM 48.8
<b>Material</b>	glas-fibre reinforced plastic
<b>Manufacturer</b>	LM Glasfiber or equivalent

## Nacelle

<b>Design</b>	semi-integrated
---------------	-----------------

## Gear box

<b>Type</b>	combined spur / planetary gear
<b>Stages</b>	3
<b>Ratio</b>	1:79.6
<b>Manufacturer</b>	Winenergy, BOSCH REXROTH

## Generator

<b>Type</b>	asynchronous, double fed induction, liquid-cooled
<b>Number</b>	1
<b>Speed</b>	750 - 1,310 rpm
<b>Voltage</b>	690 V
<b>Grid connection</b>	via converter
<b>Grid frequency</b>	50 / 60 Hz
<b>Manufacturer</b>	Winergy AG, VEM

## Control and Protection System

<b>Power limitation</b>	pitch
<b>Speed control</b>	variable via microprocessor
<b>Main brake</b>	blade pitch control
<b>Second brake system</b>	disk brake
<b>Yaw control system</b>	4 electric gear motor(s)
<b>Manufacturer of control system</b>	Mita Technik A/S
<b>SCADA-System</b>	

## Technical details

**Power curve**

**Sound power level**

**Electrical characteristics**

	<b>Tower 1</b>	<b>Tower 2</b>	<b>Tower 3</b>	<b>Tower 4</b>
<b>Hub height</b>	85.0 m	100.0 m	141.0 m	160.0 m
<b>Type</b>	steel tubular	steel tubular	lattice tower	lattice tower
<b>Shape</b>	conical, cylindrical	conical, cylindrical	4-legged 4	-legged
<b>Corrosion protection</b>	multi-coated m	ulti-coated g	alvanised	galvanised
<b>Manufacturer</b>			SeeBA	SeeBA
<b>Weight</b>				
<b>Single blade</b>				
<b>Hub (incl. installed equipment)</b>				
<b>Rotor (incl. hub)</b>	55.0 t	55.0 t		
<b>Nacelle (without rotor &amp; hub)</b>	126.0 t	126.0 t		
<b>Tower</b>	210.0 t	285.0 t		
<b>Total weight</b>	391.0 t	466.0 t		
<b>Type Approval</b>				
<b>Guideline, Class</b>				
<b>Survival wind speed</b>				
<b>Tested (month/year)</b>				
<b>Reference energy yield</b>				
<b>kWh/a</b>	0.00 7	,677,264.00 <sup>2)</sup> 0 .00		0.00
<b>Price</b>				
<b>Turbine (excl. VAT)</b>				
<b>Scope of Supply</b>				
<b>Warranty</b>	2 years 2	years 2	years 2	years
<b>References (14/10/2008)</b>				
<b>Installed turbines worldwide</b>	12			
<b>First installation in</b>				
<b>Special features</b>				
<b>Miscellaneous</b>				
Installed turbines are FL 2500 - 100 with 100.0 m steel tubular tower.				