

Control system on a wind turbine

Steffen Andreas Varpe

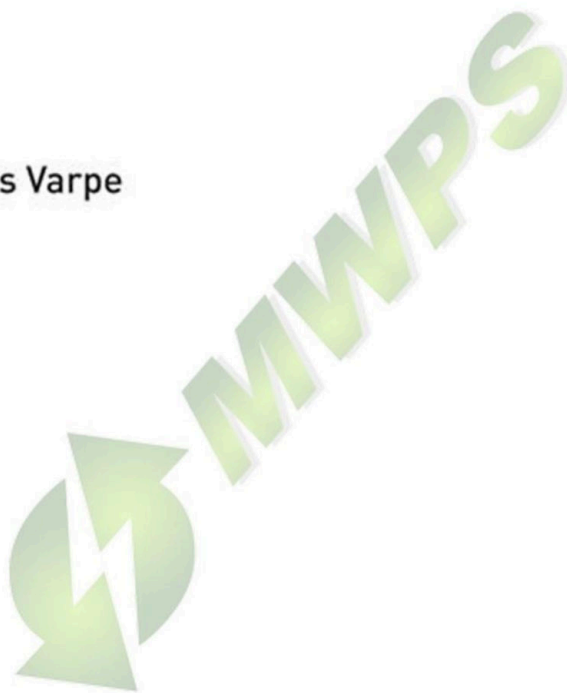

Master of Science in Product Design and Manufacturing
Submission date: May 2008
Supervisor: Ole Gunnar Dahlhaug, EPT

Problem Description

The objective of the project is to develop a control system for a wind turbine modified with a hydraulic transmission

The project is to be performed according to the following agenda.:

1. Literature study
 - a. Get familiar with wind turbine control systems
2. Component and program knowledge
 - a. Get familiar with different components included in a wind turbine control system
 - b. Make a wind turbine model using Matlab and Simulink
3. Develop a control system for a wind turbine with the following strategies
 - a. Constant speed
 - b. Constant tip speed ratio

Assignment given: 25. January 2008
Supervisor: Ole Gunnar Dahlhaug, EPT

Preface

My interests for dynamics, hydrodynamics, mechanics and control engineering made this project a natural choice for me. During the project I have had the possibility to be creative and test out some of my own ideas related to wind turbine controlling. The presses have been both inspiring and instructive in a wide range of technological subjects.

I would like to thank my supervisors, and some of my fellow students for supporting me during my work with my master thesis.

Steffen Andreas Varpe

Trondheim, 17.05.2008

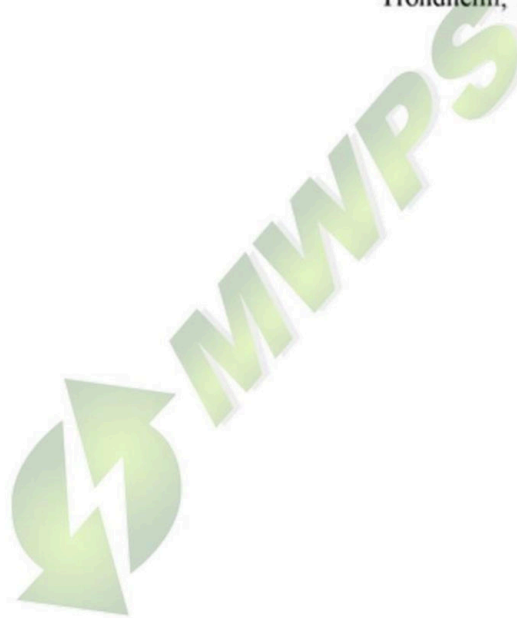

Summary

The aim for this project is to prepare a wind turbine controller and a wind turbine computer model suitable for controller development. The wind turbine is a Vestas V27, and the wind turbine drive train is modified by ChapDrive with a specified hydraulic transmission. Both the pitch and the rotor speed can be regulated for the modified wind turbine. The model is primarily based on a set of given wind turbine rotor characteristics, transmission specifications and transmission test data. The controller does not rely on an accurate wind speed gauge, since it can be difficult to realize.

A control strategy was developed with special emphasis on energy efficiency for the modified wind turbine. Efficiency test data from the transmission prototype were only available for a limited operating range, so a final control strategy could not be confirmed for the whole operating range. Despite of the limited transmission efficiency data the traditional wind turbine control strategy including operation at a constant tip speed ratio is rejected. Calculations clearly show that the transmission efficiency is affecting how the wind turbine should be operated. The strategy includes details on how to ideally control the pitch and the rotor speed for different wind conditions. Following the strategy is realized without using an accurate wind gauge.

The developed wind turbine controller was tested showing good results. It was tested against a turbulent wind model that is developed as a part of the project. The described controller concept could possibly be developed further for implementation in the modified Vestas V27. It should be stressed that alternative controller realization concepts should be considered before a final decision is made.

Further work on this topic should be dedicated to clarify the ideal control strategy for the whole operating range of the wind turbine. This requires more information on the transmission prototype or a more accurate transmission model.

List of contents

1	Introduction	1
2	Background	2
2.1	Project status	2
2.2	Hydraulic transmission basics.....	2
2.3	Vestas V27 basics	4
3	Wind turbine model	5
3.1	Transmission model.....	5
3.1.1	Mathematical model in time domain	5
3.1.2	Mathematical model in Laplace domain.....	9
3.2	Rotor model	11
3.2.1	Rotor model for normal operating conditions.....	11
3.2.2	Rotor model for startup conditions	13
3.3	Effective wind model.....	14
4	Control objectives	15
4.1	Energy capture	16
4.2	Mechanical loads	17
4.2.1	Rotor speed restrictions.....	17
4.2.2	Hydraulic transmission restrictions.....	18
4.2.3	Pitch mechanism restrictions	18
4.2.4	Generator power.....	18
5	Control strategy	18
5.1	Generator speed	18
5.2	Rotor speed	19
5.3	Power restriction	25
6	Control realization	26
6.1	Secondary controller realization	26
6.1.1	Hydraulic transmission characteristics	27
6.1.2	Initial tuning and reference response	28
6.1.3	Disturbance response	33
6.2	Primary Controller realization	35
6.2.1	Pitch regulation	35
6.2.2	Speed regulation.....	38
6.2.3	Over speed pitch control (OSPC)	44
7	Discussion	47
8	Conclusion	50
9	Further work	51

List of tables

Table 1: Hydraulic transmission specifications [Chapple P. J., 2007]	4
Table 2: Vestas V27 specifications [Haugset S. K., 2007].....	4
Table 3: Measurements from Valsneset obtained by IFE [Pettersen O. J., 2007]	14
Table 4: Initial controller settings	31
Table 5: Final controller displacement setting.....	34
Table 6: Pitch regulation summary	38
Table 7: Speed regulation summary	44
Table 8: OSPC summary	47

List of figures

Figure 1, Hydraulic driven generator.....	2
Figure 2: Transmission dynamical behavior.....	3
Figure 3: Hydraulic transmission, principle sketch	3
Figure 4: System sketch of hydraulic transmission model	5
Figure 5: Motor mechanical efficiency.....	7
Figure 6: Generator torque vs. speed	8
Figure 7: Basic block diagram	10
Figure 8: $C_p(\text{TSR}, \text{Pitch})$	11
Figure 9: Best pitch.....	12
Figure 10: Pitch control model	13
Figure 11: Rotor torque Look up table	13
Figure 12: Effective wind model	14
Figure 13: Effective wind speed	15
Figure 14: Ideal power curve	16
Figure 15: Transmission efficiency	19
Figure 16: Variable speed variable pitch strategy.....	20
Figure 17: C_p curve [Haugset S. K., 2006].....	21
Figure 18: Best C_p curve	21
Figure 19: Extrapolated and interpolated transmission efficiency	22
Figure 20: Overall efficiency 3-D plot.....	23
Figure 21: Overall efficiency in wind rotor speed plane	24
Figure 22: Primary and secondary control	26
Figure 23: Linear approximation	27
Figure 24: Bode plot without regulator, $\omega_p(s)/D_m(s)$	28
Figure 25: Proportional feedback loop	28
Figure 26: Rotor speed step response	29
Figure 27: Pump diff. pressure step response	30
Figure 28: P, PI, PID controller	31
Figure 29: Open loop Bode plot with regulator, $\omega(s)/e(s)$	31

Figure 30: Turbine speed reference step response, PID	32
Figure 31: PID controller with damped reference	32
Figure 32: Closed loop torque step response	33
Figure 33: Rotor speed wind step response	34
Figure 34: Pitch search flow chart, method 1	35
Figure 35: Pitch search flow chart, method 2	37
Figure 36: Searching pitch regulator.....	37
Figure 37: Searching pitch regulator, zoomed view	37
Figure 38: Best pitch angle	39
Figure 39: Rotor speed reference.....	40
Figure 40: Best pitch angle	40
Figure 41: Wind speed estimator	41
Figure 42: Estimated TSR.....	41
Figure 43: Speed and pitch regulator, average wind speed of 7.5 m/s.....	42
Figure 44: Rotor speed vs. wind speed	42
Figure 45: Rotor speed vs. wind speed on top of efficiency chart.....	43
Figure 46: Over-speed pitch action.....	45
Figure 47: Over-speed torque impact	45
Figure 48: Rotor speed step response	46
Figure 49: Model efficiency vs. real prototype efficiency.....	48

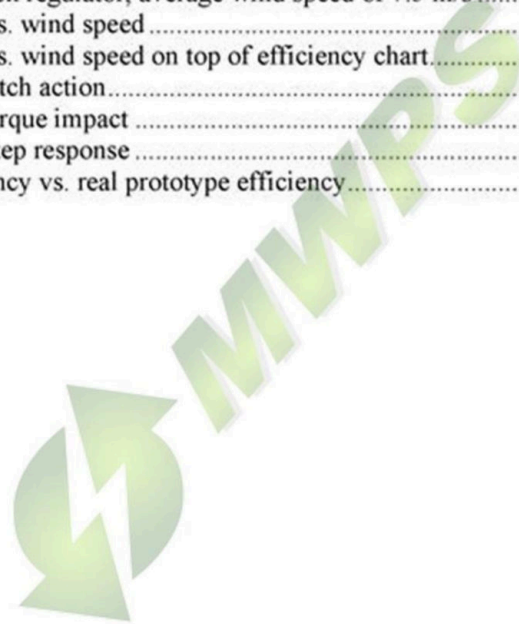

Main symbols

α	Pipeline pressure drop coefficient	[Ns/m ⁵]
B	Effective Bulk modulus	[Pa]
C _p	Rotor efficiency	[-]
D	Displacement	[m ³ /rad]
f	Generator torque factor	[Nms/rad]
J	Inertia	[kgm ²]
K	Gain	[-]
krpm	Thousand rpm in SI unit	[rad/s]
λ	Leakage coefficient	[m ⁵ /Ns]
η	Efficiency	[-]
P	Power	[W]
Q	Volumetric flow	[m ³ /sec]
R	Rotor radius	[m]
ρ	Air density	[kg/m ³]
σ_w	Wind speed standard deviation	[m/s]
T	Torque	[Nm]
t	Time constant	[s]
V	Wind speed	[m/s]
V ₀	High pressure side volume	[m ³]
ω	Rotational speed	[rad/s]
Δp	Pressure difference	[Pa]

Subscripts

T	Turbine
G	Generator
m	Hydraulic motor
N	Corresponding to maximum nominal power
Ω	Corresponding to maximum rotor speed
p	Hydraulic pump
trans	Hydraulic transmission
mec	Mechanical
v	Volumetric
l	Leakage
c	Controller
i	Integral
d	Derivative
w	Wind speed

Abbreviations

OSPC	Over Speed Pitch Control
PI	Proportional Integrating
PID	Proportional Integrating Derivative
TSR	Tip Speed Ratio

1 Introduction

Chapdrive has developed a light weight hydraulic transmission prototype for use in wind turbines. The transmission is designed to replace traditional mechanical gear boxes. Hydraulic power transmission makes it possible to move weight from the nacelle to ground level. A weight reduction will reduce the requirement of tower stiffness, and will possibly lower the cost of tower production, transportation and installation. At the same time it can play an important role in developing offshore floating wind turbines. The hydraulic transmission has a steep gear ratio which enables the rotor to change speed independent of the generator. This requires a wind turbine controller that is capable of controlling both pitch and rotor speed. The hydraulic transmission has an efficiency that is strongly dependent of how it is operated. It is therefore important that the wind turbine controller runs the turbine in such a way that the product of the rotor efficiency and the transmission efficiency is optimized.

During the first months of 2008 the hydraulic transmission prototype has successfully been installed in a Vestas V27, located at Valsneset outside Trondheim. First the modified wind turbine will be controlled manually, after initial testing an automatic controller will be implemented. The main aim of this test is to confirm whether the transmission works as intended. The results of the test are of interest for further development of the transmission, but it is also important as a milestone for the investors. The value of the technology is beyond any doubt related to the overall efficiency of a wind turbine modified with the new transmission, and the measured efficiency during testing is most likely critical regarding further investments in the project. It is important to maximize the efficiency for these tests in order to prove the potential in this technology, and the efficiency should be a preferred quality when making the initial wind turbine controller. Factors such as sustainability and power quality can be improved at a later stage.

The main aim of this master thesis is to create an initial design of a controller for a Vestas V27 modified with hydraulic transmission. The development of a wind turbine controller requires a model of both the rotor and the hydraulic transmission. These models will be developed in Matlab and Simulink as a part of this master thesis. Later the models will be used to develop and test a regulating regime. The development of the wind turbine model and the wind turbine regulator will emphasis on the most distinctive aspects associated with regulation of a wind turbine with hydraulic transmission. The most distinctive new features are variable turbine speed, highly variable transmission efficiency and significantly lower torsion stiffness between the rotor and the generator. Even though the pitch mechanism will remain unchanged, the pitch controller will be affected by the hydraulic transmission modification the way it is controlled in an original Vestas V27. A new pitch controller will therefore have to be developed.

Features such as yaw regulation will not have to differ from yaw regulation in conventionally wind turbines and will not be discussed. Wind turbine start up, and controller implementation details has only partly discussed due to time constrains.

2 Background

In March 2006 a master thesis was completed on building and testing of a small scale hydraulic transmission. It was tested and evaluated at the hydraulics lab at NTNU showing promising results. ChapDrive AS was established December 2006 in order to do further developing of the concept taking it to large scale, and to commercialize it.

The new technology reduces the weight of a wind turbine transmission and makes it possible to move the generator from the wind turbine nacelle to ground level. The new technology also makes it possible to control the rotor speed independent of the generator.

2.1 Project status

A prototype was built and tested in 2007. This test is documented in Field measurement on a wind turbine [Varpe S. A, 2007]. The test was performed with a diesel engine simulating the wind turbine rotor. The prototype is now installed for testing in a Vestas V27 wind turbine located on Valsneset. The original control system at the Vestas V27 can not be used to control the turbine modified with the hydraulic transmission, and the turbine will for the initial tests be controlled manually. Later a new control system will be developed and implemented.

Svein Kjetil Haugset has developed data for the rotor. Based on the blade element momentum method he has developed steady state performance data on the rotor for different pitch settings, rotor speeds and wind speeds in form of efficiency curves and Torque curves [Haugset S. K., 2007].

Peter Chapple has developed a complex dynamic model of the hydraulic transmission. His model has been converted into a Simulink model by Sintef. This model is not available for use in this project.

2.2 Hydraulic transmission basics

Chapdrive's hydraulic transmission is designed to replace traditional mechanical gear boxes in wind turbines. A hydraulic pump is attached to the wind turbine shaft, and power is transferred to ground level through steel pipes inside the tower. At ground level a hydraulic motor, with variable displacement, converts the energy back to rotational energy and feed it to a generator. Due to a variable displacement motor it is possible to control the gear ratio, and the rotational speed of the rotor can be varied independent of the generator speed. Figure 1 shows a principal sketch of the hydraulic drive train system.

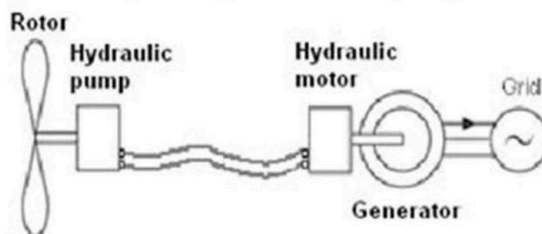

Figure 1, Hydraulic driven generator

A hydraulic transmission will change the dynamic behavior of a wind turbine. The compressibility of the oil together with flexing of pipes and hoses will result in a great amount of elasticity between the rotor and the generator. This effect would be similar to driveshaft torsion in mechanical gearboxes, see Figure 2. The equivalent torsion stiffness is much lower in Chapdrive's hydraulic transmission compared with a conventional mechanical gearbox. The compressibility makes it possible for the rotor speed and the generator speed to oscillate with a much lower frequency than what is the case with a mechanical gearbox. Another important difference between a mechanical and a hydraulic transmission is the effect caused by internal leakage in the hydraulic system. The leakage changes the gear ratio for different loads, and the motor displacement must be changed to compensate for the leakage and maintain a constant gear ratio, see Figure 2.

Rotor Compressibility and leakage

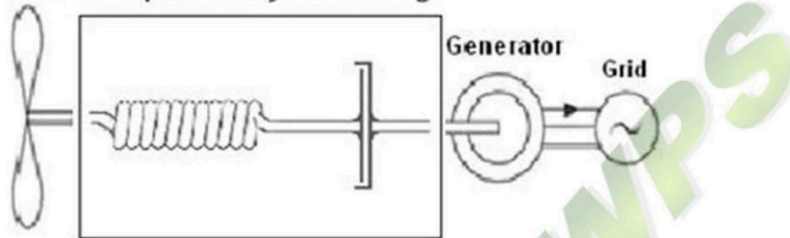

Figure 2: Transmission dynamical behavior

The pump and the motor are coupled in a closed loop and a boost system is necessary to compensate for leakage. The boost system supplies the low pressure side of the closed loop with a minimum pressure. This is done to avoid cavitation at the pump inlet, see Figure 3.

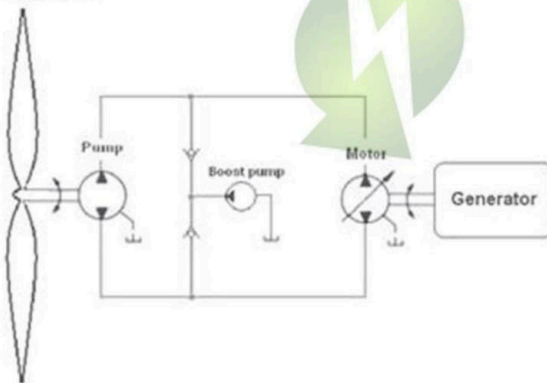

Figure 3: Hydraulic transmission, principle sketch

The main components of the hydraulic system and their location are listed below

Nacelle

- Pump, Hägglunds CA
- Swivel, Custom made

Container

- Motor, Bosh Rexroth A4
- Generator, asynchronous type
- Reservoir
- Boos pump
- Oil cooler

Some of the most important specifications on the hydraulic transmission is listed in

Hydraulic transmission specifications	
Boost pressure	15bar
Maximum oil pressure	310bar
Motor displacement	$3.18 \cdot 10^{-5} \text{ m}^3/\text{rad}$ to $7.96 \cdot 10^{-5} \text{ m}^3/\text{rad}$
Pump displacement	$1.8 \cdot 10^{-3} \text{ m}^3/\text{rad}$
Total motor and generator inertia	15[kgm ²]
Total rotor and pump inertia	30000[kgm ²]

Table 1: Hydraulic transmission specifications [Chapple P. J., 2007]

Further details on ChapDrive's hydraulic transmission can be found in Field measurements on a wind turbine [Varpe S. A., 2007]

2.3 Vestas V27 basics

The basic specifications of an original Vestas V27 is listed in Table 2

Vestas V27 specifications	
Number of blades	3
Tip radius	13.5m
Regulation system	Pitch regulation Yaw regulation
Max pitch changing speed	12 deg/s
Cut in speed	3m/s
Cut out speed	25m/s
Design wind speed	8m/s
Rated power output	225kW
Generator	Two asynchronous, grid connected generators: 50kW 225kW
Speed of rotation	Two fixed speed of rotation: 33rpm 43rpm

Table 2: Vestas V27 specifications [Haugset S. K., 2007]

3 Wind turbine model

The wind turbine model will consist of two parts, the rotor and the hydraulic transmission including a generator. The wind will be simulated by a separate effective wind model.

3.1 Transmission model

A mathematical model of the transmission is made to later produce a Laplace transformed block diagram. This is a widespread method of treating dynamical systems for regulating purposes. The resulting block diagram is to be imported into Simulink. Simulink will then be used to analyze the system, and to design a regulation controller for the transmission.

The model is made with focus on the dynamical properties that is important for regulating purposes. Qualities such as energy efficiency accuracy have not been a preferred feature, and the model should under no circumstances be used to produce efficiency data. The hydraulic transmission prototype has been tested in a limited part of its operating range. Test data from these tests are available and is used to obtain properties such as pump/motor leakage and pipeline pressure drop.

The model will for simplicity matters use the differential pressure over the pump and the motor as the hydraulic pressure parameter. The absolute pressure at the high pressure side will be greater than the differential pressure. To find the absolute pressure at the high pressure side, the pressure at the low pressure side must be added to the differential pressure.

3.1.1 Mathematical model in time domain

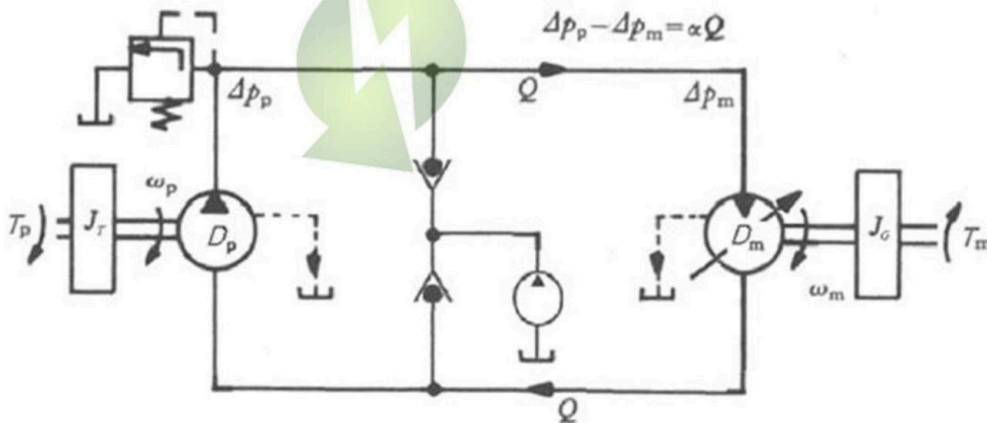

Figure 4: System sketch of hydraulic transmission model

The relation between pump torque and differential pressure can be found based on the mechanical efficiency, as shown in Equation 1.

$$T_p \cdot \omega_p \cdot \eta_{mec,p} \cdot \eta_{v,p} = Q \cdot \Delta p_p = D_p \cdot \eta_{v,p} \cdot \Delta p_p \quad [W] \quad \text{Equation 1}$$

$$T_p = \frac{\Delta p_p \cdot D_p}{\eta_{mec,p}} \quad [Nm]$$

Equation 1 combined with Newton's 2. law results in Equation 2.

$$J_T \dot{\omega}_p = T_T - \frac{\Delta p_p \cdot D_p}{\eta_{m,p}} \quad [Nm] \quad \text{Equation 2}$$

The sum of internal and external leakage in both pump and motor can be assumed to be linear dependent of the differential pressure. This is reasonable since the leakage path will be of a small cross section area compared with the total wetted area, and the flow velocity will be small [Goodwin A.B, 1976]. Test results from Marienborg also indicate that this is a good assumption especially with pump power input above 100 kW [Varpe S. V, 2007].

$$Q_{l,p} = \lambda_p \cdot \Delta p_p \quad [m^3/s] \quad \text{Equation 3}$$

$$Q_{l,m} = \lambda_m \cdot \Delta p_m \quad [m^3/s] \quad \text{Equation 4}$$

Based on the continuity equation for transient conditions the following differential equation can be developed.

$$Q = \omega_p \cdot D_p - \lambda_p \cdot \Delta p_p - \frac{dV}{dt} \quad [m^3/s] \quad \text{Equation 5}$$

$$Q = \omega_p \cdot D_p - \lambda_p \cdot \Delta p_p - \frac{V_0}{B} \frac{d(\Delta p_p)}{dt} \quad [m^3/s]$$

The compression of the total oil volume is assumed to be linear dependent to the applied pressure. The effective bulk modulus B includes elasticity of the boundaries.

Pipeline pressure drop is assumed to be laminar and linearly dependent of the volumetric flow since the Reynolds number will be in the range of 1000. The assumption correlates well with data from the tested range of the transmission [Varpe S. V., 2007].

$$\Delta p_p - \Delta p_m = \alpha \cdot Q \quad [Pa] \quad \text{Equation 6}$$

$$\omega_m \cdot D_m = Q - \lambda_m \cdot \Delta p_m \quad [m^3/s] \quad \text{Equation 7}$$

$$\eta_{mec,m}(\Delta p_m) \cdot D_m \cdot \Delta p_m = T_m \quad [Nm] \quad \text{Equation 8}$$

All the pump and motor efficiencies, except from the motor mechanical efficiency, are almost constant for the operating range that was tested [Varpe S. A., 2007]. However the mechanical efficiency was strongly dependent of the motor differential pressure especially for low pressures, se Figure 5. The dependency of the motor displacement seems to be insignificant and is ignored.

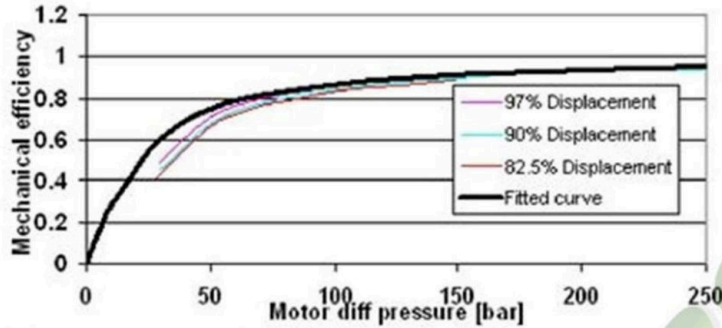

Figure 5: Motor mechanical efficiency

The fitted curve in Figure 5 is represented by Equation 9. Pa represents the unit Pascal and is included in the expression to get the units right.

$$\eta_{mec,m} = 1 - \frac{18[Pa]}{30[Pa] + \Delta p_m} - \frac{400[Pa]^{1.5}}{1000[Pa]^{1.5} + 15(\Delta p_m)^{1.5}} \quad [-] \quad \text{Equation 9}$$

The variable motor efficiency does not impact the frequency response between displacement and rotor speed. This can be explained by the fact that a drop in motor mechanical efficiency will lead to a decrease in motor torque. When the torque input to the generator drops, the rotational speed of the generator drops only marginally, se Figure 6. When the generator speed is nearly constant, the volume flow and the rotor speed will also remain constant. Therefore it will not affect the dynamics of the rotor speed significantly. What it will affect is the generator torque and thus the output power. The output power will be affected especially for low motor differential pressure, which is obtained by strong wind combined with low rotor speed. The output power will be used as a feedback for regulating purposes, and the strongly variable motor mechanical efficiency should therefore be included in the model. Another nonlinearity that must be maintained in the model is the product of the motor displacement and the rotational speed, see Equation 8. Both the differential pressure over the motor and the displacement needs to be varied when the model is used for regulation purposes. Neither of them can therefore be assumed to be constant in the model.

The generator torque is modeled with a linear relation to the rotational speed and is zero at 1000 rpm. This will be valid for rotational speeds close to 1000 rpm. For large deviations the real generator torque curve will flatten out as shown in Figure 6.

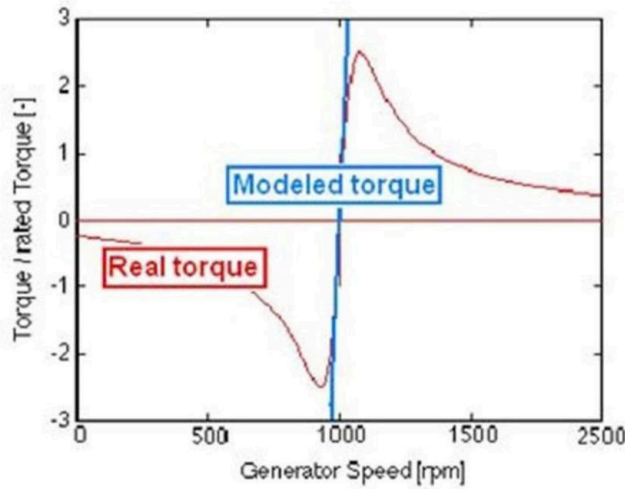

Figure 6: Generator torque vs. speed

Equation 10 defines the generator curve. f represent the inclination of the blue curve in Figure 6.

$$T_G = \left[\omega_m - \left(\frac{1000}{60} \cdot 2\pi \right) \right] \cdot f \quad [\text{Nm}] \quad \text{Equation 10}$$

$$T_m = J_G \dot{\omega}_m + \left[\omega_m - \left(\frac{1000}{60} \cdot 2\pi \right) \right] \cdot f \quad [\text{Nm}] \quad \text{Equation 11}$$

Both the inertia of the generator and the motor is included in J_G . Therefore the torque T_m will not represent the actual torque in the driveshaft between the motor and the generator. It will rather represent the torque in the driveshaft given that the generator had all the inertia. In a steady state case where there is no acceleration the calculated torque will represent the real torque in the driveshaft between the motor and the generator.

Equation 11 combined with Equation 8 become

$$\eta_{mec,m} \cdot D_m \cdot \Delta p_m = J_G \dot{\omega}_m + \left[\omega_m - \left(\frac{1000}{60} \cdot 2\pi \right) \right] \cdot f \quad [-] \quad \text{Equation 12}$$

If the generator does not produce any counter torque the constant f can be set as zero. Then the only contributor to torque will be the inertia. This could be of interest for a startup simulation.

It is important to be aware of the simplifications and assumptions that is included in the described mathematical model. The most critical of them is listed below.

Important linearizations:

- Motor and pump leakage is linearly dependent on differential pressure from inlet to outlet.
- Pressure drop in pipes is linearly dependent to the volume flow Q for all Reynolds numbers.
- The generator has a linear relation between torque and rotational speed.

Other important assumptions:

- Pressure changes simultaneously in the hydraulic system. No propagation lags.
- Constant mechanical efficiency for hydraulic pump

3.1.2 Mathematical model in Laplace domain

Following all the equations derived in the previous chapter will be represented in Laplace domain, also called the s domain. This is achieved by Laplace transformation.

The laplace transform of Equation 2 is

$$\omega_p(s) = \frac{1}{J_T \cdot s} \left[T_T(s) - \frac{\Delta p_p(s) \cdot D_p}{\eta_{mec,p}} \right] \quad [\text{Rad/s}] \quad \text{Equation 13}$$

The laplace transform of Equation 5 is

$$\Delta p_p(s) = \frac{(\omega_p(s) \cdot D_p - Q(s)) \cdot \frac{1}{\lambda_p}}{\left(1 + \frac{V_0}{B\lambda_p} \cdot s \right)} \quad [\text{Pa}] \quad \text{Equation 14}$$

From Equation 6 we get

$$Q(s) = \frac{\Delta p_p(s) - \Delta p_m(s)}{\alpha} \quad [\text{m}^3/\text{s}] \quad \text{Equation 15}$$

Equation 7 becomes

$$\Delta p_m(s) = \frac{Q(s) - \omega_m(s) \cdot D_m(s)}{\lambda_m} \quad [\text{Pa}] \quad \text{Equation 16}$$

Finally Equation 12 results in

$$\omega_m(s) = \frac{\eta_{m,m}(\Delta p_m) \cdot D_m(s) \cdot \Delta p_m(s) + \left(\frac{1000}{60} \cdot 2\pi\right)}{\left(1 + \frac{J_G}{f} \cdot s\right)} \quad [\text{Rad/s}] \quad \text{Equation 17}$$

$$krpm = \frac{1000}{60} \cdot 2\pi \quad [1/s] \quad \text{Equation 18}$$

$$t_1 = \frac{V_0}{B \cdot \lambda_p} \quad [s] \quad \text{Equation 19}$$

$$t_2 = \frac{J_G}{f} \quad [s] \quad \text{Equation 20}$$

The variable displacement motor has a certain response time for change in displacement. The response of the motor displacement controller is modeled as a first order transfer function with a time constant of 0.5 seconds.

Based on the above expressions a block diagram can be obtained. A basic block diagram for the hydraulic transmission is presented in Figure 7. In addition to the hydraulic transmission the block diagram includes generator torque, and inertia for both rotor and generator, this will further be referred to as the wind turbine drive train. A more detailed block diagram is presented in appendix 3. The block diagram is based on an activated generator, meaning that the generator will produce momentum linearly dependent to the speed deviation from 1000 rpm. According to Figure 6 this will only be valid with small speed deviations from the point of operation. For larger deviations, such as for wind turbine start up, the generator will be deactivated by setting f equal to zero in Equation 12.

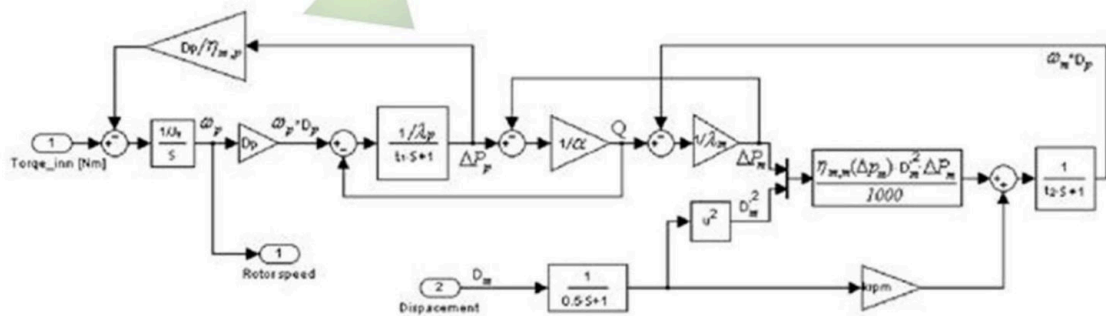

Figure 7: Basic block diagram

The controlled parameter for the transmission is the rotor speed. The speed is to be regulated at a given reference value. The speed reference can be constant or relative to other parameters, such as the wind speed. The disturbance for the system is the torque

input from the turbine. Maintaining a given rotor speed is obtained by regulating the displacement by changing the displacement input.

3.2 Rotor model

The rotor is a three bladed variable pitch type and it provides the torque input for the hydraulic transmission. The main parameters that decide the torque output is the wind speed, the rotational speed and the blade pitch angle.

Turbine performance data has been provided by Svein Kjetil Haugset. The data is calculated based on steady state calculations and thus dynamic behaviors are excluded. Effects such as blade flexing, tower movement and tower wake effect will then be neglected. Some of these effects will be compensated for by using a specially adopted wind model. This wind model approach is described in *IEEE Transactions on Power Systems* 17 [Petru T. and Thringer T., 2001]. The model will be discussed more thoroughgoing in chapter 3.3, wind model.

3.2.1 Rotor model for normal operating conditions

The calculated rotor efficiency (C_p value) for the Vestas 27 turbine is given as a tabulated function of both pitch angle and TSR, $C_p = C_p(TSR, Pitch)$. This relation is implemented as a lookup table in Simulink. The relation is illustrated in Figure 8.

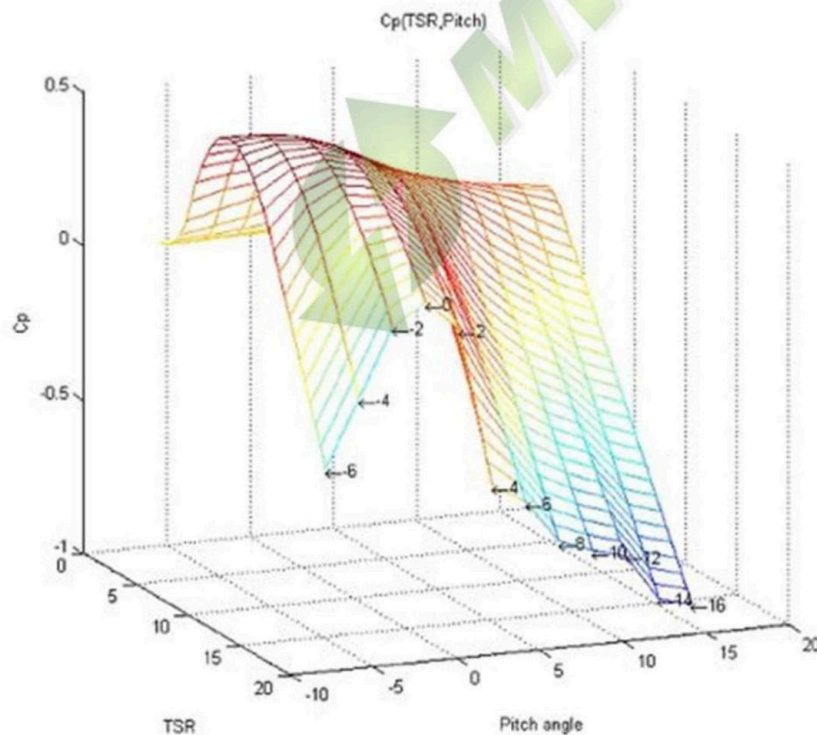

Figure 8: $C_p(TSR, Pitch)$

The rotor efficiency, C_p , is defined by the following equation [Burton T., Sharpe D., Jenkins N., Bossanyi E., 2001]

$$C_p(TSR, Pitch) = \frac{\omega \cdot T}{\frac{1}{2} \cdot \rho \cdot V^3 \cdot A} \quad [-] \quad \text{Equation 21}$$

By rearranging Equation 21 we get an expression for the torque.

$$T = \frac{C_p(TSR, Pitch) \cdot \frac{1}{2} \cdot \rho \cdot V^3 \cdot \pi \cdot R^2}{\omega} \quad [\text{Nm}] \quad \text{Equation 22}$$

From Equation 22 it is clear that it can potentially be difficult to operate with low or zero rotor speed. If the rotor speed is zero the C_p value will also become zero. An equation containing zero divided by zero can be solved using L'Hôpital's rule. The solution will then be a result of the derivative of the C_p curve when ω approaches zero. Using L'Hôpital's rule is difficult since the values of C_p are tabulated. An alternative way to simulate the rotor torque for low or zero rotor speed is outlined in chapter 3.2.2.

The torque can be found if the pitch, the rotor speed, and wind speed is known. There is no implemented pitch regulating system at this state. In order to do simulations before such a system is designed the blade pitch angle are assumed to be adjusted to the optimal angle. The optimal angle is extracted from the information in Figure 8. Then a new table with the best pitch angles, as a function of the TSR, is produced, se Figure 9.

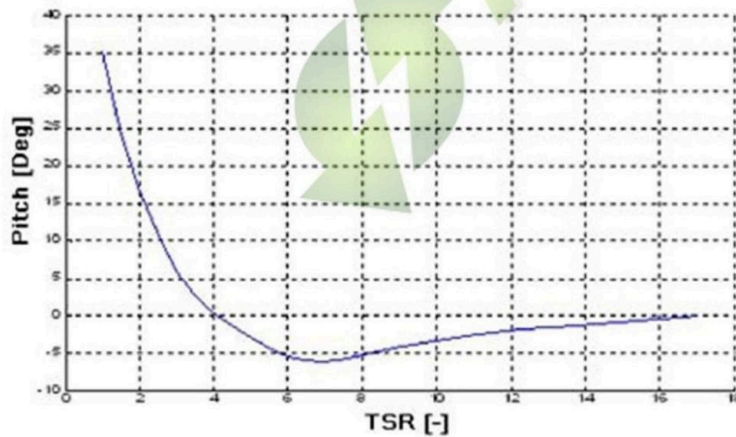

Figure 9: Best pitch

The pitch adjustment will need some time to adjust to the existing conditions. This will be restricted by the maximum pitch changing speed of 12 degrees/second, but mostly it will be limited by the process of finding the right angle. To simulate the sluggishness in the pitch regulator, a first order transfer function with a time constant of 5 seconds is used

to dampen the best pitch information. The rate limiter models the maximum pitching speed, see Figure 10.

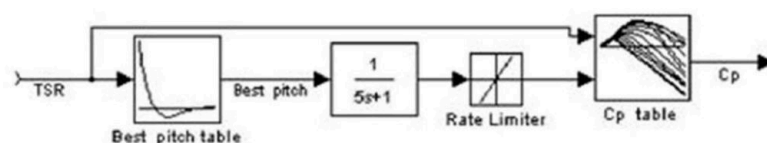

Figure 10: Pitch control model

The damped best pitch controller is useful for initial testing and as a bench marking reference for a developed pitch controller.

3.2.2 Rotor model for startup conditions

For start up conditions the rotor speed will start from zero rpm. As mentioned in the previous chapter, the C_p information can then not be used to extract the rotor torque. Instead a table with information on rotor torque at different wind speed and TSR is used. The table is based on the assumption that the pitch at all time is ideal. This is realistic since the pitch during startup can be pre programmed in a startup routine. A turbine startup will occur at approximately the same wind speed every time. Thus the only variable for optimum pitch is the rotor speed. The rotor speed can be measured and the pitch angle can thereby be adjusted.

For practical reasons the torque table will be based on the TSR, and the wind speed. Figure 11 shows the information implemented in the look up table. The read line represents the limit for the turbine rotor speed. Above this line the rotor speed is more than 43 rpm. This area is therefore not valid and can not be used. It should also be noted that some of the information in this area is extrapolated since the look up table demands values for every input combination.

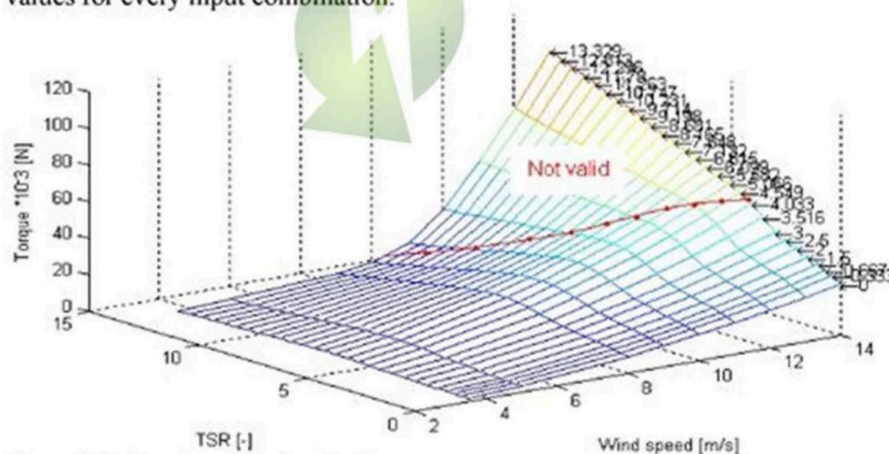

Figure 11: Rotor torque Look up table

3.3 Effective wind model

A realistic wind model is necessary for assessment of the controller performance. The wind model will be implemented in the Simulink model providing the C_p lookup table with information on wind speed. The wind speed will instantly be converted to a torque based on the C_p curve. The direct connection between wind speed and torque is taken in to account for the effective wind model where this relation is damped by a factor related to the average wind speed. Details on the damping factor are presented in appendix 5.

The so called aerodynamic filter approach has shown to provide quite realistic turbine torque when combined with a C_p lookup table [Petru, T., et al., 2002]. This approach consists of a series of filters which is fed with white noise. White noise provides normally distributed random numbers with a flat Power Spectra Density. The filter set up is illustrated in Figure 12. This approach does not take in to account the tower shadow or the wind shear.

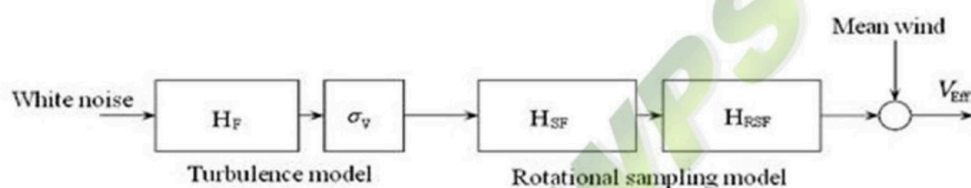

Figure 12: Effective wind model

The two first blocks represents a turbulence model for a fixed point in hub height, while the two next blocks filter this fixed point turbulence to an effective wind speed “felt” by the rotor hub.

The first filter, H_F , is a low-pass filter realized by a second order transfer function. This filter will have nearly the same frequency response as the Von Karman Spectrum [Leithead W., Connor, B., 2000]. The second block, σ_w , represents the wind speed standard deviation. The standard deviation is a product of the average wind speed and the wind speed variation. The wind speed variation, σ_w/\bar{V} is assumed to be constant and as high as 0.16 for the whole wind range. Table 3 shows test data from Valsneset obtained by The Norwegian Institute of Energy Technology (IFE). These wind measurements indicates that a variation of 0.16 is valid for lower wind speeds. For higher wind speeds the real variation will likely be significantly lower. Making a model with a constant variation of 0.16 for higher wind speeds is a conservative assumption, and will result in higher turbulence intensity than what can be expected at Valsneset. With a constant variation the standard deviation increases linearly with increasing average wind speed.

Date	Time	Average wind speed \bar{V}	Standard deviation σ_w	Variation σ_w/\bar{V}
22.02.2006	12.00-12.10	12.73	1.10	0.086
28.02.2006	02.00-02.10	6.46	0.71	0.110
03.03.2006	21.30-21.40	3.33	0.52	0.156
18.03.2006	11.30-11.40	8.92	0.63	0.071

Table 3: Measurements from Valsneset obtained by IFE [Pettersen O. J., 2007]

HSF damps high frequency components present in the wind, this way the filtering property of the large swept area of the rotor blades is present. The last filter represents the rotational wind sampling effect of the turbine rotor, and the filter amplifies wind variations at a frequency region close to the blade passing frequency. A more detailed block diagram of the effective wind model is shown in appendix 3. The different filters are specified in appendix 4.

Figure 13 shows a plot of the effective wind speed with an average wind speed of 10 m/s. The rotational speed is 43 rpm. The second plot is zoomed in to show the small amplitude sinus shaped oscillations. The constant oscillation comes from the rotational sampling effect of the wind turbine rotor. These oscillations are among other factors produced based on the rotor speed which remains constant throughout a simulation, even if the actual rotor speed is changed.

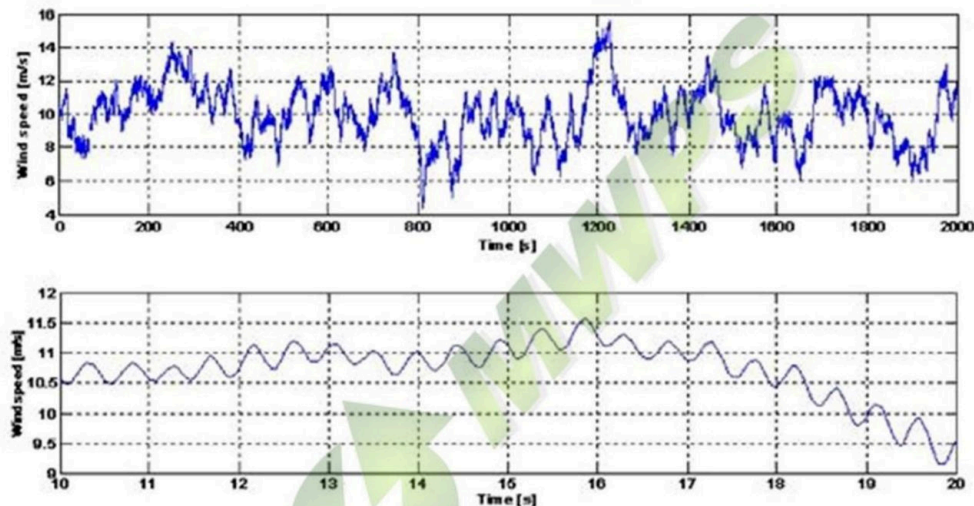

Figure 13: Effective wind speed

4 Control objectives

Before the work on the controller design is started it is important to clarify the requirements to such a system. It is common to arrange the control objectives into three different categories [Bianchi D. F., De Battista H. and Mantz R. J, 2007].

- **Energy capture:** Maximizing energy capture taking in to account the limitations of the wind turbine. The overall efficiency of the rotor and transmission must be maximized to provide highest possible power production.
- **Mechanical loads:** Preventing excessive dynamic mechanical load. Traditionally the main limitations are turbine speed and generator power. For the hydraulic transmission there will be additional limitations related to the hydraulic pressure.
- **Power quality:** Ensuring acceptable generated power quality

This report will put emphasis on energy capture and mechanical loads. Features that are particularly related to the hydraulic transmission modification will be threaded more thoroughgoing.

4.1 Energy capture

The Vestas V 27 has a rated power output of 225 kW at 43 RPM. Since there is no information on the maximum allowed power at the turbine driveshaft it is assumed to be 225 kW. Since there are losses in the original drive train the rated driveshaft power can be expected to be slightly higher. The assumption of 225kW is therefore a conservative estimate, and further work will be based on this assumption.

To optimize the energy extracted from the wind, the rotor should ideally be operated at a TSR of 8 with a pitch angle of -4 deg [Haugset S. K, 2007]. Operation at this TSR and pitch will result in the highest C_p , see Figure 17. The C_p curve is based on finite element method with some uncertainty regarding blade profiles. The real best point should later be obtained by test results from the turbine.

A typical power curve is sketched in Figure 14. The wind turbine will operate between the limits of the cut in speed (V_{min}) and the cut out speed (V_{max}). The turbine will remain stopped beyond these limits. Below the cut in speed the power production is most likely to low to compensate for operational costs. Above cut out wind speed the turbine is shut down to prevent structural overload.

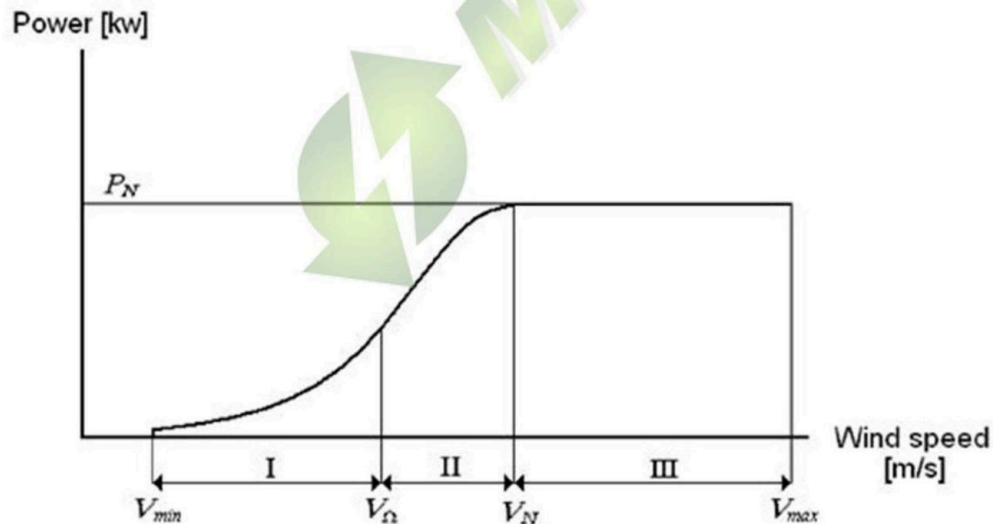

Figure 14: Ideal power curve

The power curve in Figure 14 is divided into three sections. The first represent the section where the optimal C_p ideally is maintained by changing the rotor speed according to the wind speed. In this section the rotor can operate with both variable speed and variable pitch. In section II the optimum TSR can no longer be maintained. To maintain the optimum TSR the turbine speed has to increase proportionally with the wind speed, see

Equation 23. The rotor speed is restricted to 43 RPM. With a TSR of 8 this corresponds to a wind speed of $V_{\Omega} = 7.6$ m/s. From this wind speed onwards the turbine will operate at constant rotational speed. The turbine is now only pitch regulated. For wind speeds above V_{Ω} the TSR will decrease and the pitch will have to change to maintain the best possible efficiency.

$$TSR = \frac{\omega \cdot R}{V} \quad [-] \quad \text{Equation 23}$$

In section III the wind turbine operate at constant power. At wind speeds = V_N the wind turbine reaches its nominal power P_N . For higher wind speeds the amount of extracted power must be restricted to avoid overloading. This will be achieved by pitching the blades to a less effective angle. At wind speeds above V_{max} the wind turbine is shut down.

4.2 Mechanical loads

The control system must restrict mechanical loads to an acceptable level. There are three main differences between the conventional operation of a Vestas V27 and how it will be operated modified with Chapdrive's hydraulic transmission. First the modifications will cause a drastic reduction in tower weight. This causes the natural frequency of the tower to increase. The new natural frequency is not known at this stage. If the rotational speed with a multiple of the number of blades hits the natural frequency it could lead to a devastating resonance. Secondly the rotor will be able to operate at variable speed. The frequency of the cyclic loads changes in proportion to the rotor speed and the range of permissible speed somehow has to be restricted [Leithead W, 2000]. The last major difference is the transmission dynamics. A relatively large volume of oil introduces elasticity between the rotor and the generator, making it possible for the rotor speed to oscillate at considerably lower frequencies than with a mechanical gearbox.

4.2.1 Rotor speed restrictions

Questions regarding tower natural frequency and restrictions on the rotor speed will not be discussed since the natural frequency is not known at this time. Limitations on the rotor speed must possibly be implemented in the wind turbine controller if there is risk of interfering with the natural frequency of the tower. The natural frequency is not known at this stage so this speed restriction will not be discussed further. The rated rotor speed of the Vestas V27 is 43 rpm. Most likely there is a safety margin so the rotor can withstand higher speeds, at least for shorter periods. There is no available information beyond the rated rotor speed. Regarding Svein Kjetil Haugset we can assume that the rotor speed under no circumstances should exceed 45 rpm, 4.7 rad/sec. Based on this statement it is assumed that the safety factor for the rotor is 5% of the rated speed. When developing a rotor speed controller the maximum operating speed will be set to 43 rpm. For shorter periods, under extreme conditions, the rotor speed is allowed to exceed the rated speed of 43 rpm by 2.5%. For further work these assumptions should be re evaluated.

4.2.2 Hydraulic transmission restrictions

Under a steady state the hydraulic pressure will reach its critical limit before both the pump and motor driveshaft torque so the pressure is the restricting parameter. The hydraulic maximum pressure can be exceeded by a steady state overload, or it could be caused by transient situations. The steady state overload is avoided since the transmission is designed to withstand the steady state pressure according to the maximum wind turbine torque. A transient phase could be introduced by changes in motor displacement. The pressure will increase if the rotor is decelerated. How rapid the displacement and the rotor speed can be regulated have to be limited by the hydraulic system pressure. Excessive rotor drive shaft torque due to acceleration is neglected since the inertia of the motor is insignificant compared to the inertia of the rotor.

4.2.3 Pitch mechanism restrictions

The pitch actuator can, referring to Svein Kjetil Haugset, change the pitch speed with a speed of 12 deg/s. An aggressive pitch controller will cause increased wear on the pitch drive mechanism. If the pitch drive mechanism is vulnerable to frequent and rapid pitch change it could likely be modified to withstand this. The pitch controller will be developed with the only limitation of a pitch changing speed of 12 deg/s.

4.2.4 Generator power

The generator has a rated maximum power of 225 kW. The power is restricted by changing the blade pitch angle to a less effective setting, also called pitch to feather.

5 Control strategy

There are different ways of controlling a wind turbine in order to meet the control objectives. In this chapter one alternative way of controlling the modified Vestas V27 is developed.

5.1 Generator speed

The original Vestas V27 is of a two fixed speed, variable pitch type. The generator can change between 750 and 1000 rpm mode. When using a hydraulic transmission with stepless gear ratio it is not necessary to operate with both generator speeds to achieve a full turbine speed range. Despite that it could be beneficial to use both generator speeds in order to operate the transmission at the most efficient operating range. Test results indicate that the transmission is more efficient when the generator is operating at 750 rpm. Unfortunately there are not sufficient results from this test to conclude on whether this is the case for lower displacements and low power inputs, see Figure 15. For TSR=8 and a wind speed of 4 m/s the displacement will be approximately 50 % if the generator operates at 1000 rpm. If the generator alternatively operates at 750 rpm the displacement will be approximately 67%. The input power would be approximately 10kW. For this case it is not obvious if operating at 750 rpm or 1000 rpm is gives the best efficiency. Whether there are reasons to use both generator speeds can be answered when a complete

power curve is produced. Due to the lack of test results the controller developed in this project will be based on a 1000 rpm generator.

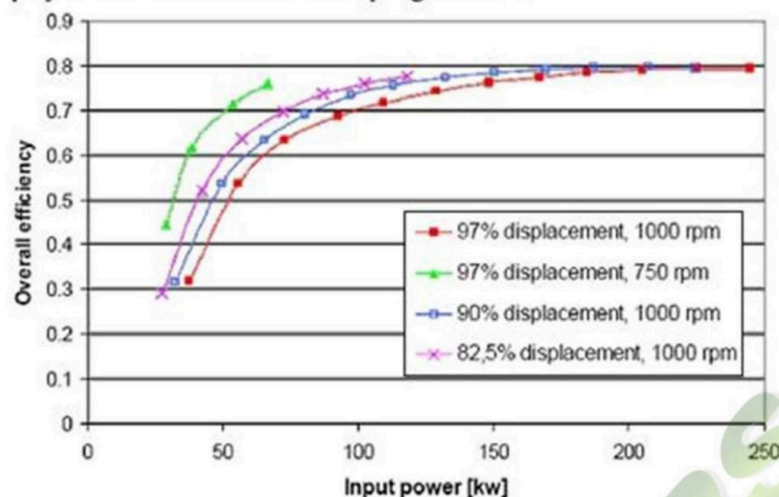

Figure 15: Transmission efficiency [Varpe S. A., 2007]

5.2 Rotor speed

The rotor speed can be varied from 1.87 rad/sec to a maximum of 4.5 rad/sec. The maximum operating speed is restricted by the nominal rated speed of the rotor, while the minimum speed is restricted by the hydraulic transmission gear ratio. The best rotor efficiency is obtained with a rotor speed corresponding to one constant TSR, meaning that the speed at all times should be a constant multiple of the wind speed [Leithead W, 2000]. From Figure 17 it can be seen that the optimum rotor efficiency is obtained around a $TSR=8$. The TSR can be maintained at this value until the wind speed reaches 7.6 m/s and the rotor speed is 4.5 rad/s. This point is marked as point B in Figure 16. On the line AB the turbine can be operated at the optimum C_p value of 0.478, and follow the C_p locus curve, see Figure 16. The locus curve crosses the torque curve for each wind speed at its highest power rating, resulting in highest possible power at each wind speed. After point B the speed is held constant while the pitch is changed to match the decreasing TSR. Now the turbine will no longer operate at the best C_p coefficient, and it leaves the C_p locus curve and moves vertically on the line BC in the torque-speed plot in Figure 16.

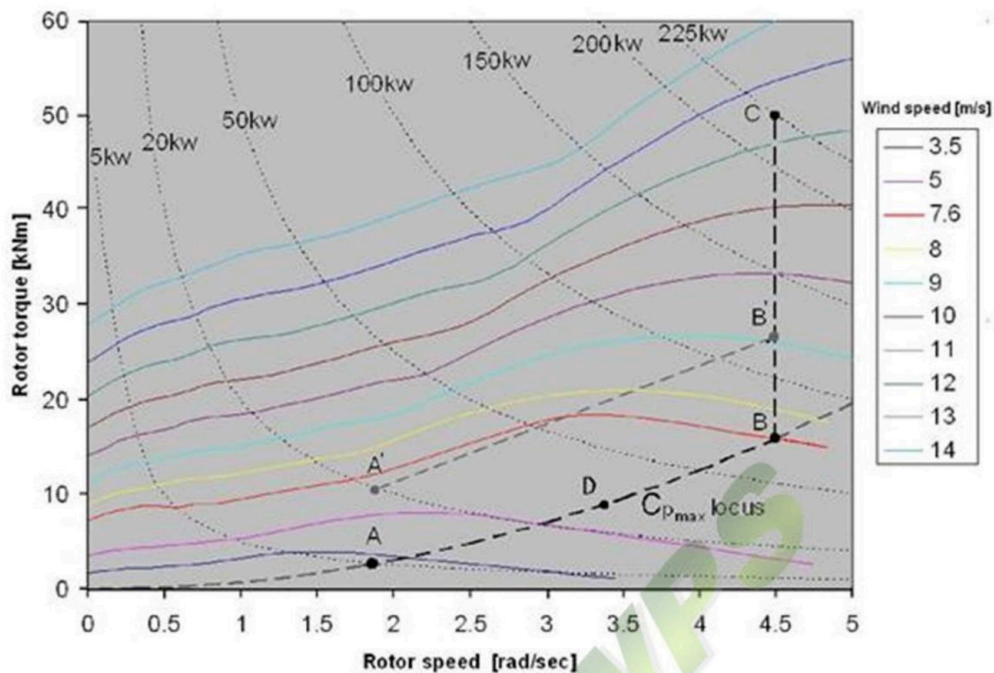

Figure 16: Variable speed variable pitch strategy

Line AD in Figure 16 is the operation area where the generator alternatively could be running at 750 rpm in order to enhance the efficiency of the transmission. From D to B the generator must operate at higher speeds if the C_p locus curve is to be followed.

Aerodynamically the TSR should be held constant to get the best performance of the rotor, and from that point of view the C_p locus curve in Figure 16 should be followed. If the transmission efficiency included this is not necessarily the truth. From Figure 17 it is clear how there are relatively small changes in the C_p value for TSR between 6 and 10. Otherwise Figure 15 illustrates how strongly dependent the transmission efficiency is related to the motor displacement, and thus the exchange ratio. If the motor displacement is lowered the transmission efficiency is increased. At the same time the rotor speed will be decreased and the TSR will be changed. Now the transmission efficiency is increased and the rotor efficiency is decreased. It is therefore not obvious which TSR that would result in the overall best efficiency.

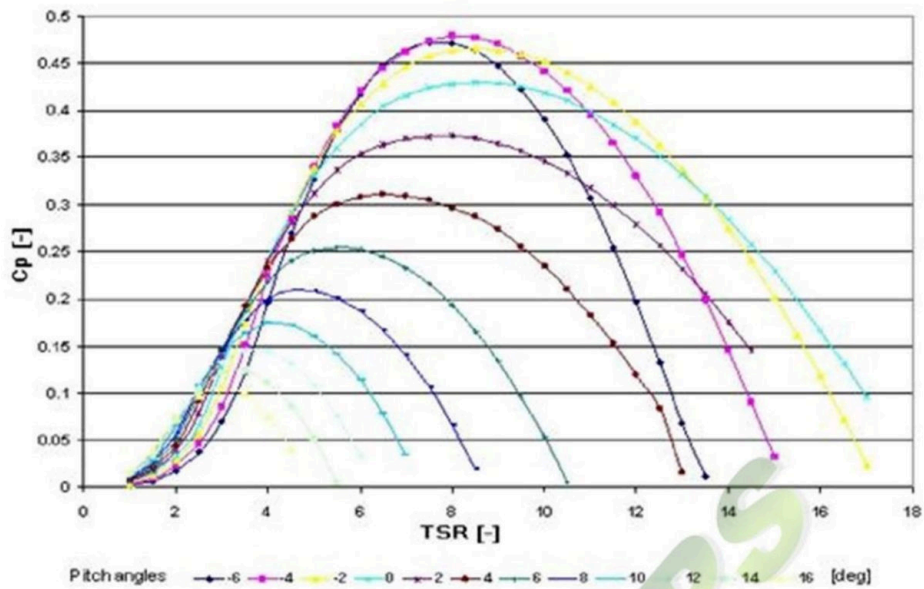

Figure 17: Cp curve [Haugset S. K., 2006]

The overall efficiency is dependent of both rotor and transmission efficiency. If the overall wind turbine efficiency can be made based on wind speed and rotor speed, a plot of the overall efficiency can be made in the wind rotor speed plane.

The overall efficiency is given by

$$\eta_{tot} = C_{p_{best_pitch}} \cdot \eta_{trans}$$

While the rotor efficiency is given by

$$C_{p_{best_pitch}} = f(\omega_p, V)$$

The best Cp curve in Figure 18 is developed based on the information found in Figure 17.

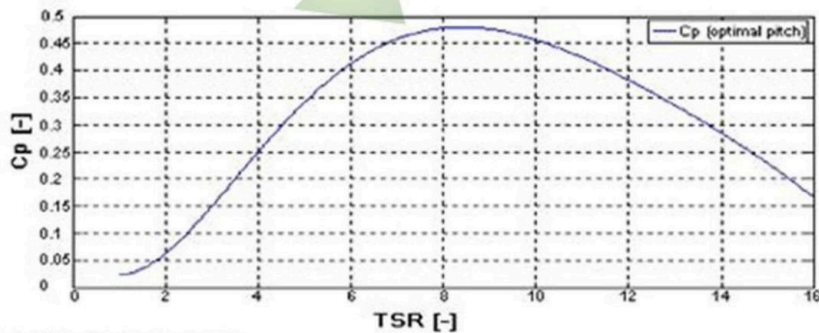

Figure 18: Best Cp curve

The transmission efficiency is only known for a limited operating range stretching from approximately 3 to 4 rad/sec rotor speed. Information from Figure 15 is linearly extrapolated to provide information about the transmission efficiency from 80% to 100%

motor displacement. Values in between the test values are found by linear interpolation. The result of the extrapolation and interpolation is plotted in Figure 19.

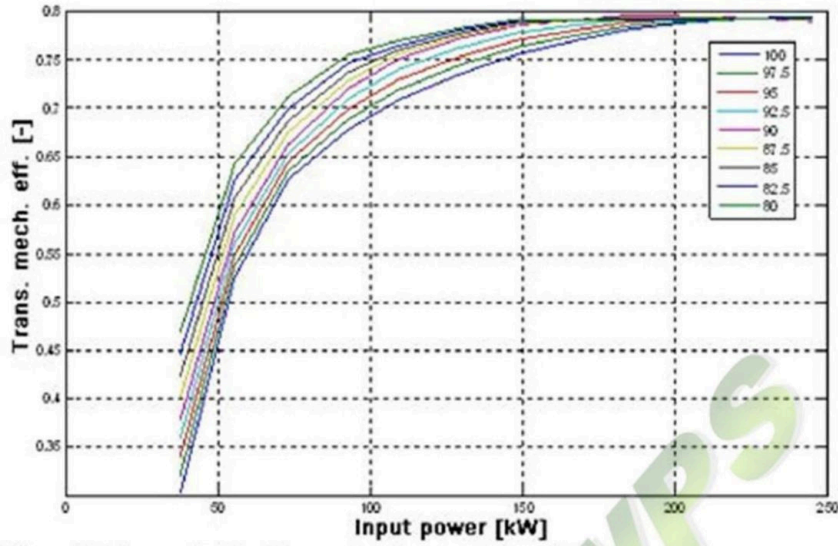

Figure 19: Extrapolated and interpolated transmission efficiency

The transmission efficiency is found from data illustrated in Figure 19. The efficiency is based on the free variables; power and motor displacement.

$$\eta_{trans} = f(P, D_m)$$

If ignoring hydraulic leakage and assuming constant generator speed, the motor displacement is linearly dependent on the rotor speed.

$$D_m \approx K_1 \omega_p + K_2 \quad [m^3/s] \quad \text{Equation 24}$$

Power input is dependent on the variables; wind speed and rotor efficiency

$$P = f(\omega_p, T) = f(\omega_p, V, C_p) = f(\omega_p, V)$$

$$\eta_{Trans} = f(V, \omega_p)$$

Finally there is a term of the overall efficiency based on wind speed and rotor speed.

$$\eta_{tot} = C_{P_{best_pitch}}(\omega_p, V) \cdot \eta_{trans}(\omega_p, V) \quad [-] \quad \text{Equation 25}$$

The overall efficiency, η_{tot} , is plotted in Figure 20.

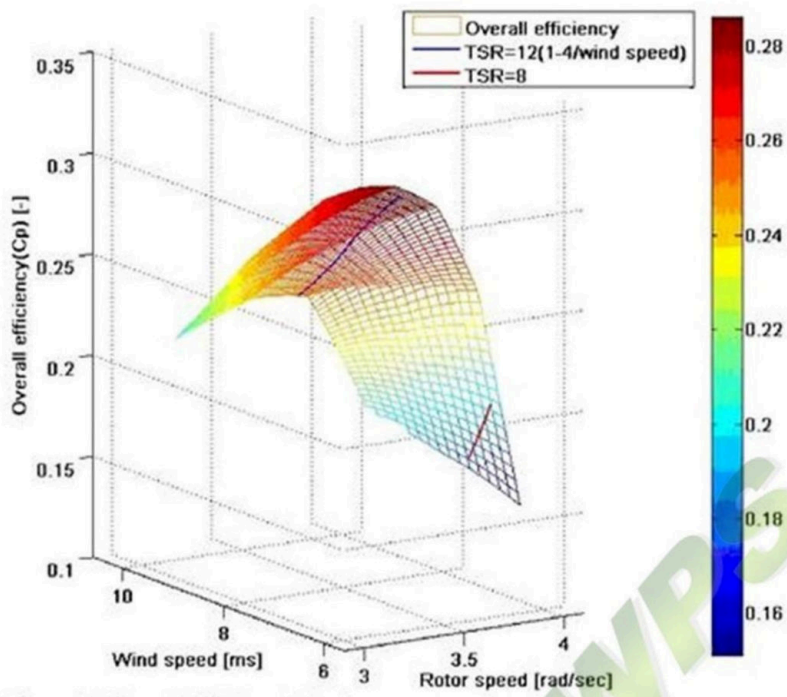

Figure 20: Overall efficiency 3-D plot

The red line illustrates a constant TSR of 8, while the blue line illustrates a variable TSR dependent on the wind speed. The expression for this variable $TSR = 12 * (1 - 4 / \text{wind speed})$

The overall efficiency is only known for a very limited operating area as shown in Figure 21. From Figure 21 it seems that for wind speeds between 7 and 10 m/s there is little or nothing to gain from changing the rotor speed. For wind speeds below 7m/s it is more likely that there are advantages from lowering the rotor speed according to lower wind speeds.

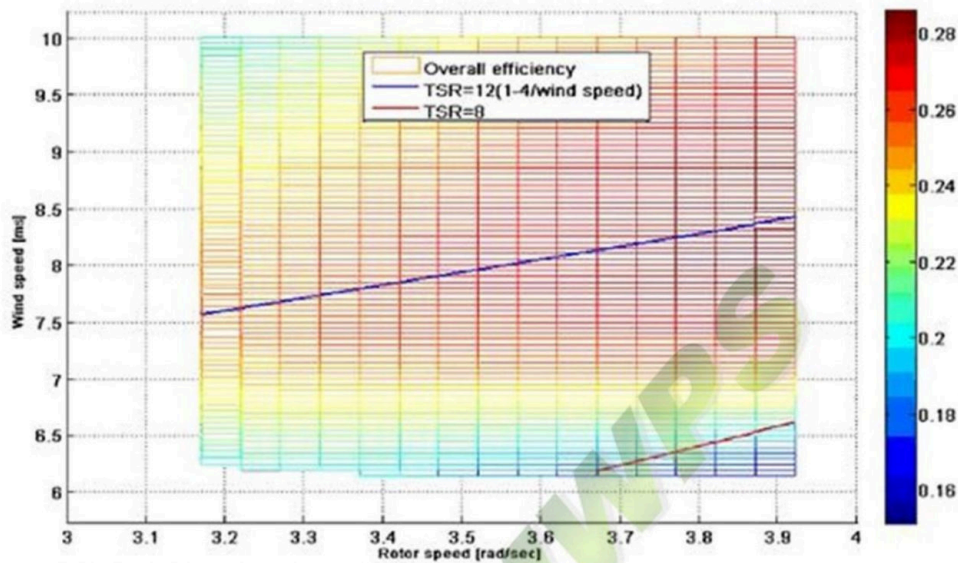

Figure 21: Overall efficiency in wind rotor speed plane

This efficiency curve should be known for the whole operating range in order to operate the turbine at the best rotor speed. Since the efficiency curve is not completely known, it is assumed that the best efficiency is maintained with a linear relation between the rotor speed and the wind speed as expressed in Equation 26.

$$\omega = \frac{12}{R}(V - 4) \quad [\text{rad/s}] \quad \text{Equation 26}$$

The same relation is plotted with a blue line in Figure 21.

This relation can be modified to the variable TSR stated in Equation 27.

$$TSR = 12\left(1 - \frac{4}{V}\right) \quad [-] \quad \text{Equation 27}$$

Due to a rotor speed limitation of 4.5 rad/s, the optimum variable TSR can only be obtained until a wind speed of 9.1 m/s. At 9.1 m/s wind speed the TSR should, according to Equation 27, be 6.7.

This variable TSR will later be referred to as the optimum TSR. It should be stressed that this curve does not have to represent the most efficient way of running the turbine. This specially counts for the operating ranges that are not covered by the efficiency chart in Figure 21. Even in the area where the overall efficiency is calculated it seems to be more

efficient to run the rotor at constant speed for a restricted wind range. If the rotor speed for instance is kept at 3.9 rad/s the wind can fluctuate a lot before the efficiency drops dramatically. This is not the case at lower rotor speeds, to the left in Figure 21 where the best efficiency band is narrower.

There are doubts regarding how the TSR and the rotor speed should vary with different wind speeds, and the model can not be used to test the overall efficiency due to its inaccuracy. This topic is further discussed in chapter 7.

The wind turbine should be able to maintain a TSR that proves to be most efficient. This will also be the focus when developing a controller in this project, and the optimum TSR in Equation 27 will be assumed to be the most efficient operating points for the overall wind turbine. The quality of the controller can then be related to how closely the controller manages to follow this optimum TSR.

One of the major challenges of obtaining a given TSR is the wind speed measurement. In order for the controller to run the turbine at a given TSR it somehow needs real time information on wind speed. Due to large fluctuations in wind speed this can not be achieved with a conventionally wind measurement equipment without using an average value over time. This will induce a time lag which will make the TSR control sluggish in its capabilities to maintain the reference TSR. How to solve this challenge is further discussed in chapter 6 Control realization.

5.3 Power restriction

Whether the power restrictions for the Vestas V27 are given by the generator, the rotor, or the mechanical gearbox is not known. The original Vestas V27 has a rated power output of 225 kW. The rated power output will correspond to a given rotor driveshaft power (input power), depending on the gearbox efficiency. This corresponding input power is further used as the power restriction to the turbine. The efficiency of the mechanical gearbox is also not known, but is assumed to be 0.9. The hydraulic transmission has an efficiency of around 0.8 when operating at high power input. If the mechanical gearbox is assumed to have an efficiency of 0.9, it results in a difference of approximately 11%. With the hydraulic transmission the power input will reach its assumed maximum value when the power output is 89% of the originally rated power of 225kW. The new power output must be restricted to 200kW. This is a conservative power restriction base on the assumption that the rotor is the power restricting component.

The generator output power can be restricted by the pitch controller. When the generator output power reaches 200 kW the pitch is increased to reduce the rotor efficiency. Ideally this should be realized in a way that smooth out the power output variations. This way the power produced by the generator will be of better quality. How the power restriction should be realized will not have to differ from the way power is restricted on the original Vestas V27 and will not be discussed further in this report.

6 Control realization

The current wind gauge on the Vestas V27 is located in the wake of the rotor, and it could be too unreliable for fast regulating purposes. It is likely to believe that it is manageable to improve this wind measurement. Either by filtering away the cyclic noise created by the turbine, or a pitot tube could be installed in the hub center. If reliable wind measurements can be achieved the wind velocity information can easily be used to control the rotor speed and pitch. How a reliable wind measurement can be achieved by a wing gauge will not be further discussed in this project. Instead an alternative method of how to follow the rotor control strategy will be tested. This method does not rely on an accurate wind measurement gauge.

The controller will consist of two control systems, one primary controller and one secondary controller. The primary controller controls the blade pitching and defines the rotor speed reference. The secondary transmission controller controls the displacement to obtain a rotor speed according to the reference given by the main controller.

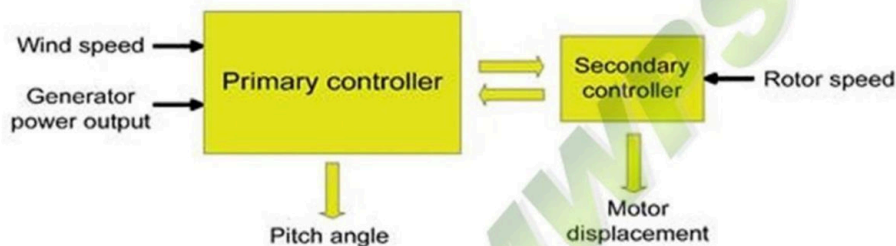

Figure 22: Primary and secondary control

The secondary controller will be discussed first since it can be developed and tested separately from the primary controller. A more detailed diagram of how the controller is set up together with the wind turbine model can be seen in appendix 3.

6.1 Secondary controller realization

The secondary controller must be able to keep the rotor speed at a certain rotational speed according to a reference. This reference could be fixed or variable depending on the regulation regime of the whole wind turbine. In both cases the transmission must be able to control the turbine speed according to a given reference. The disturbance in to the system is the rotor torque. The torque will change mainly due to change in wind speed, rotational speed and blade pitch angle.

The controller is designed so it is able to compensate for change in both reference and disturbance. The reference could for example be changed to maintain a certain TSR. The reference speed would then be changed according to the wind speed. The disturbance and the torque input will mainly be changed due to changes in wind speed, given that the pitch system works as intended. The disturbance is more likely to change faster than the reference. The change in reference can also be limited to a certain rate if rapid changes cause hazard to the system.

6.1.1 Hydraulic transmission characteristics

The wind turbine drive train characteristics should be examined to reveal important details on the systems behaviors. Some of the characteristics can be used to define good regulator settings. Later an open loop frequency response will be presented in form of a bode plot. Frequency response can only be obtained for linear systems [Balchen Jens G., Andresen Trond, Foss Bjarne A., 2004]. The non linear block diagram in Figure 7 must therefore be linearized. A linearization is carried out using Matlab and Simulink. Simulink has two different methods of producing a linear model analysis, block-by-block analytic linearization and numerical-perturbation linearization. As a precaution both method was used to produce a Bode diagram. Both methods gave practically the same results.

A linearization of a non linear function is an approximation of the real function or behavior of a system. Such an approximation can only be accurate at the point where the approximation is created, se example in Figure 23. The further away you get from this point, the more inaccurate the approximation is. The point the approximation is based on is referred to as the operating point.

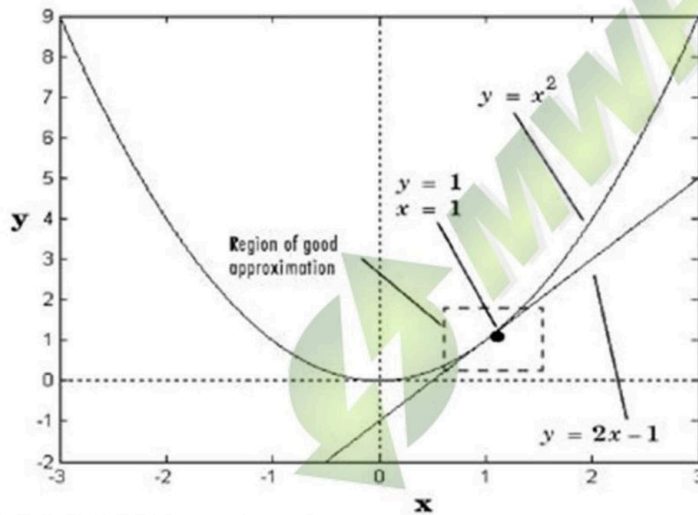

Figure 23: Linear approximation

$$\omega_p(s)/D_m(s)$$

For the hydraulic transmission there is no fixed operating point for the remaining nonlinear blocks. The variable displacement can obviously not be kept constant since it is the controlled parameter. The pressure will neither remain constant since it is directly dependent of the turbine torque and the wind speed. Since this is the case the linearization should be carried out for different operational point throughout the operating range.

The rotor speed $\omega_p(s)$ is to be controlled by the displacement $D_m(s)$ and it is important to know how these two parameters relate to each other, see Figure 7. As mentioned a Bode plot is produced based on a linear analysis using Simulink. An amplitude and frequency response of $\omega_p(s)/D_m(s)$ is then plotted for every linearization point. The plots are shown

in the bode diagram in Figure 24. It is clear how the linearization around the four different operating points results in approximately the same characteristics.

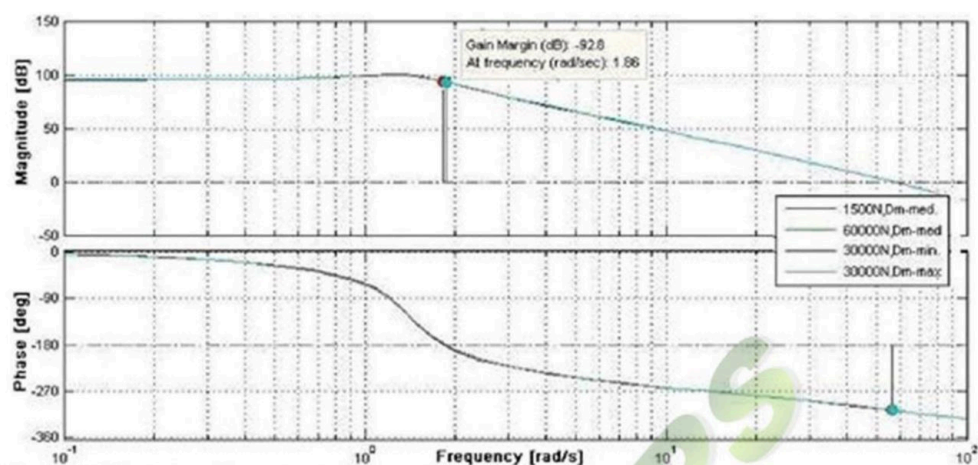

Figure 24: Bode plot without regulator, $\omega_p(s)/D_m(s)$

6.1.2 Initial tuning and reference response

Figure 24 shows that the system dynamical characteristics does not change with different operating states, thus there is no need to use different regulator settings for different operating points.

The gain margin is found from Figure 24. The gain margin is found from Figure 24 and should be positive for the system to become stable. The model will differ from the real physical model, and parameters can change during the time of operation, therefore the gain margin should be at least 6 dB [Balchen J. G, et al., 2004]. To lower the amplitude response by 98.8 dB the feedback has to be amplified by maximum -98.8dB corresponding to a gain of 0.00001148.

The feedback loop in Figure 25 is implemented in the transmission model and the gain providing a margin of 6dB is tested.

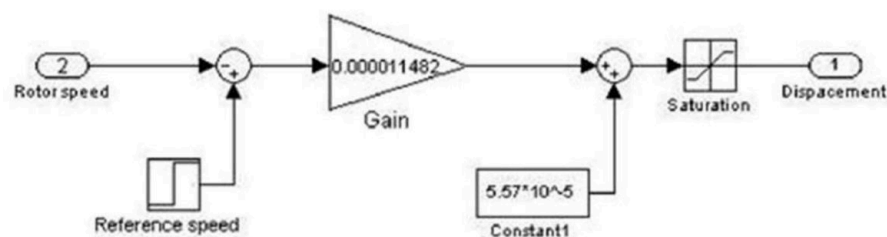

Figure 25: Proportional feedback loop

A step in the reference speed from 4.5 to 2.2 rad/s is applied after a time of 50 seconds. The rotor torque is set to a fixed 50kNm, corresponding to a rotor driveshaft power of

225kW when the rotor speed is 4.5 rad/s. This step is the largest possible and would not occur together with maximum torque during operation since there are no reason to lower the rotor speed at high wind speeds. The plot of the turbine speed in Figure 26 shows that the speed is oscillating. The proportional feedback also results in a stationary deviation from the reference speed. The deviation can be eliminated by adding an integration function to the feedback controller.

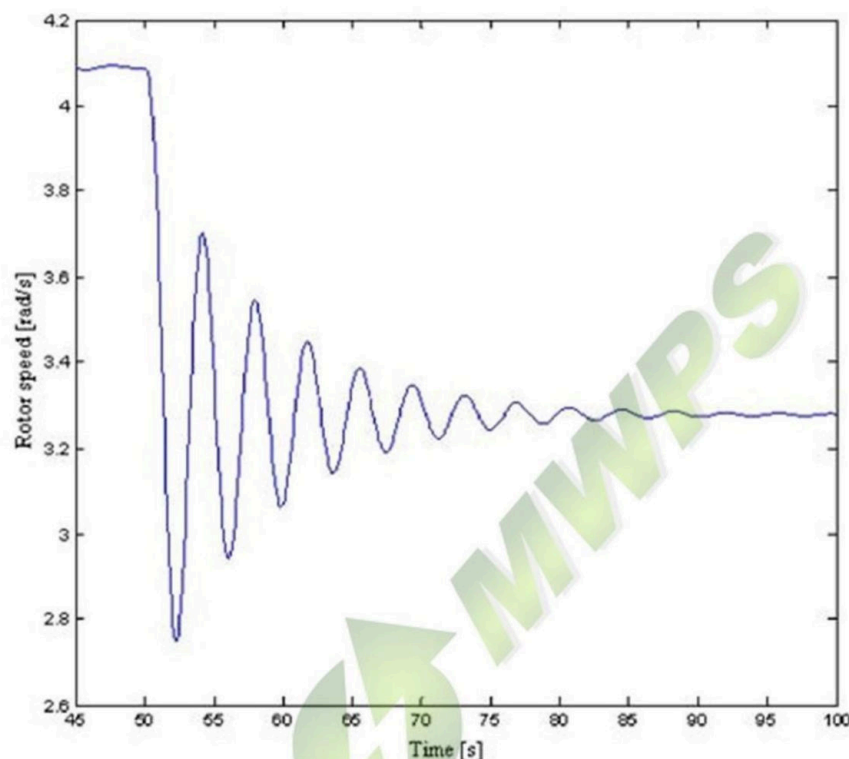

Figure 26: Rotor speed step response

The hydraulic system pressure is another parameter that has to be taken in to account when adjusting the feedback controller. If the controller is too aggressive or there will be large oscillations in the differential pressure. A plot of the differential pressure over the pump corresponding to the above mentioned step is presented in Figure 27. The pressure peaks are too high and must somehow be reduced. The pressure is closely related to the turbine torque and it is necessary to evaluate these pressure peaks with the correct torque input. If the rotational speed reference is changed to maintain optimum TSR, or by other reasons are changed, there will be changes in the rotor torque output. The torque input or the disturbance has to be included in order for the model to be realistic.

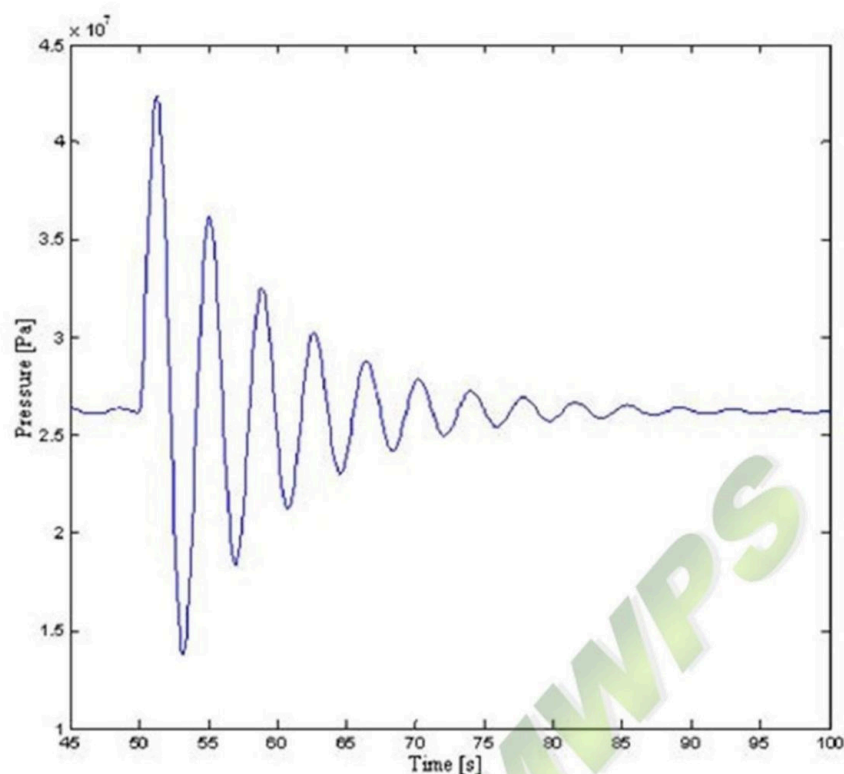

Figure 27: Pump diff. pressure step response

Adding the rotor model to define the correct torque input did not make noticeably changes to the bode diagram compared with the bode diagram for the fixed torque presented in Figure 24. Therefore the controller settings can be optimized with a fixed torque input to obtain best possible performance. The rotor torque model can later replace the fixed torque in order to check how the system parameters respond to the worst plausible step change in reference and disturbance. If any parameters reaches there safety limitations the controller can be compromised.

Figure 29 shows three Bode plots of $\omega(s)/e(s)$. The three different plots represent a P, a PI and a PID regulator together with the transmission model in an open loop where the rotor speed feedback is decoupled. The different solutions are tuned to obtain a fast reference response. The PID regulator is of a limited derivative type. The limited derivative feature makes it possible to make the controller discrete. It also eliminates the problem of derivative kick resulting from step input changes [Seborg Dale E., Edgar Thomas F., Mellichamp Duncan A., 2003]. The controller settings are listed in Table 4. The feedback controller is shown in Figure 28. The controller can be changed between P, PI and PID by disconnecting the wiring to the respective blocks.

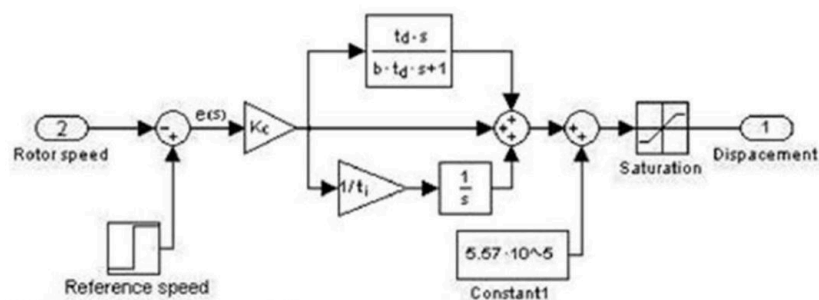

Figure 28: P, PI, PID controller

	K_c	t_i	t_d	b
P	$1.148 \cdot 10^{-5}$	-	-	-
PI	$1.0 \cdot 10^{-6}$	0.25	-	-
PID	$2.0 \cdot 10^{-6}$	0.25	2	0.025

Table 4: Initial controller settings

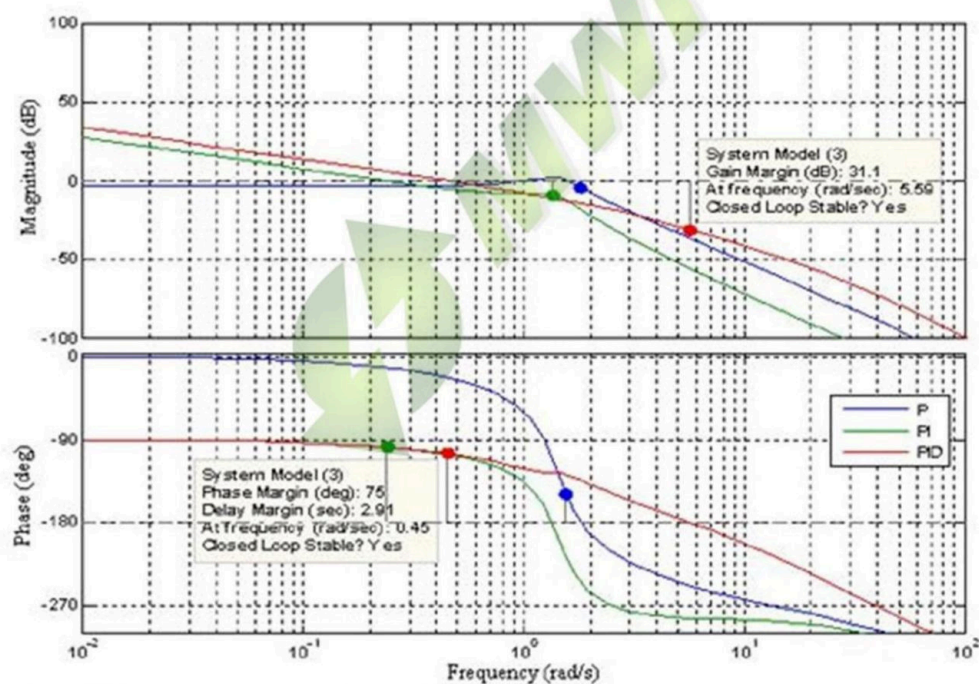

Figure 29: Open loop Bode plot with regulator, $\omega(s)/c(s)$

As mentioned previous in this chapter the integral function is necessary to avoid stationary deviations. This can also be seen in the bode plot where the blue line, illustrating the proportional regulator with a gain of 0.00001148, never can get a positive magnitude at low frequencies as long as the gain margin is above 6dB. Adding a PI regulator solves this problem, and the stationary deviation removed.

The PID function with a limited derivative function increases the band with making the system able to regulate faster. It also increases the gain margin, and oscillations in turbine speed, after a step change, is reduced. When the oscillations are gone the differential pressure over the pump also is decreased.

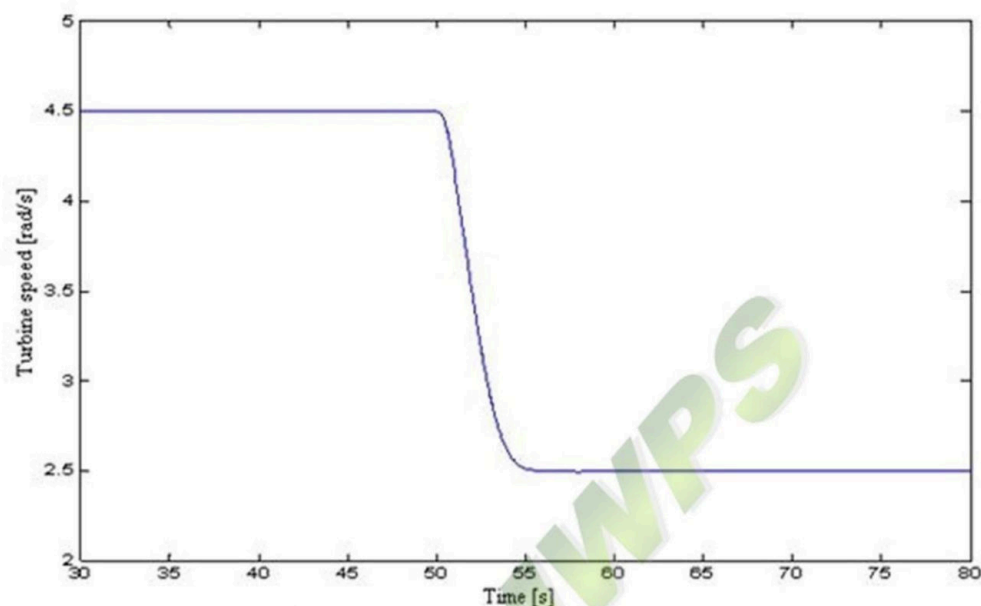

Figure 30: Turbine speed reference step response, PID

Figure 30 shows a plot of the speed response to a step change in reference speed from 4.5 to 2.5 rad/sec, still with an input torque of 50kN. The pump differential pressure reaches 370 bar, which is too high. This could be avoided by simply lowering the controller gain. With a gain of $5 \cdot 10^{-7}$ the maximum pump differential pressure for the same step change is then 295 bar. Alternatively the change rate for the reference limit is damped. This is achieved by adding a first order transfer function in series with the speed reference, see Figure 31. Using a time constant of 6 sec reduces the pressure peak to 295 bar. Damping the reference input will not restrict the controller performance with regards to the disturbance. Thus the controller can be optimized to handle the disturbance. If the controller later is changed this restriction must be re tuned.

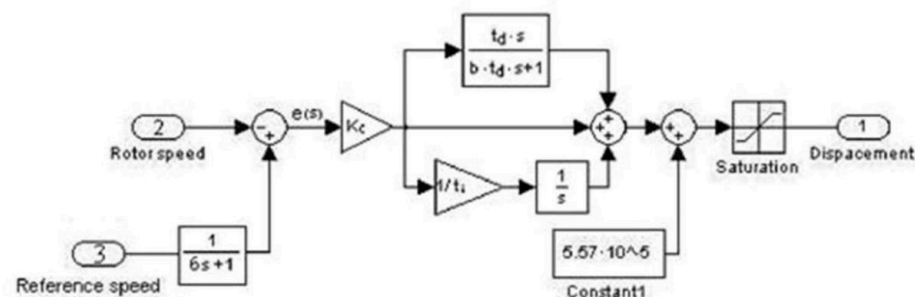

Figure 31: PID controller with damped reference

6.1.3 Disturbance response

The transmission disturbance input is the rotor torque. A wind gust can produce rapid change of pump input torque, and the rotor speed will accelerate or decelerate until the controller acts and changes the pump differential pressure. How fast the compensation can be done is obviously restricted by the system pressure and the motor displacement speed.

The PID controller settings from chapter 6.1.2 proved to work well in regards to changes in rotor speed reference. Another consideration is changes in disturbance. A step change in torque will not occur during operation. A wind gust is not a shock wave, and if there is a wind gust the velocity will increase over a certain time period. Additionally the rotor blades will have to accelerate and flex to some extent before the new torque load is transferred to the driveshaft. Applying a step change in the rotor torque will represent a more severe change in disturbance than applying the worst possible wind gust.

A torque step change from 10kN to 50kN is applied after 50 seconds. The reference speed is set to the rated rotor speed of 4.5 rad/sec equal 43 rpm, and the controller settings are maintained as shown in Table 4 for a PID controller. Figure 32 shows how the rotor speed exceeds the set point by approximately 0.9 rad/sec, 20% above the rated rotor speed.

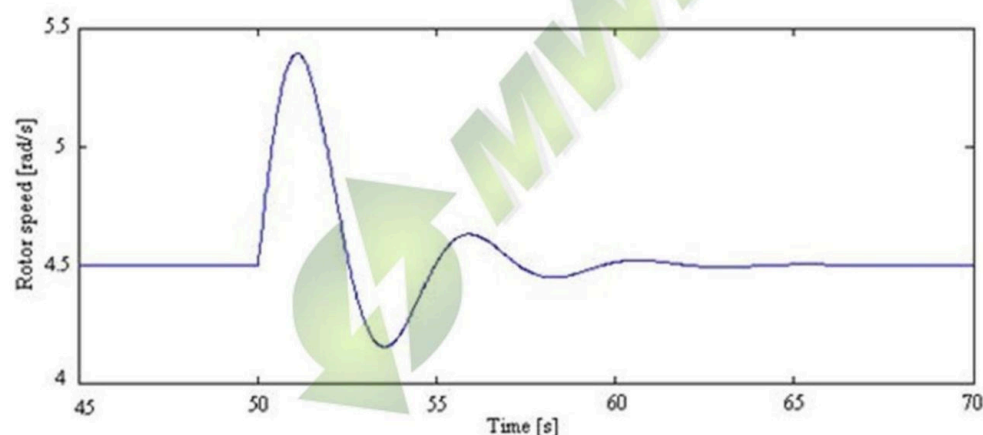

Figure 32: Closed loop torque step response

To avoid this excessive speed the controller can be tuned more aggressively, and the gain can be increased. The gain margin with the current settings is 31 dB, as seen in Figure 29 the gain can be increased corresponding to $31\text{dB} - 6\text{dB} = 25\text{dB}$. Thus the controller gain can be multiplied with as much as 12.59. This gives a new gain of $17.78 \times 2 \times 10^{-6} = 3.556 \times 10^{-5}$. In order to also maintain a phase margin of minimum 45 degrees the maximum gain allowed is only 1×10^{-5} . With this gain the speed peak is reduced to 5.12 rad/sec. A rotor speed of 5.12 rad/sec is still too high and must somehow be reduced. The controller is tuned to reduce the speed peak as far as the stability margins allows. A further reduction of the peak can be expected if a model of the turbine produced the torque input as a result of a step in wind speed.

After implementing the turbine model, a step in wind speed was applied. For the step to be comparable with the previous torque step, the change in wind speed was set to go from 6.56 m/s to 12.7 m/s corresponding to a change in torque from 10kNm to 50kNm. The resulting rotor speed response can be seen in Figure 33

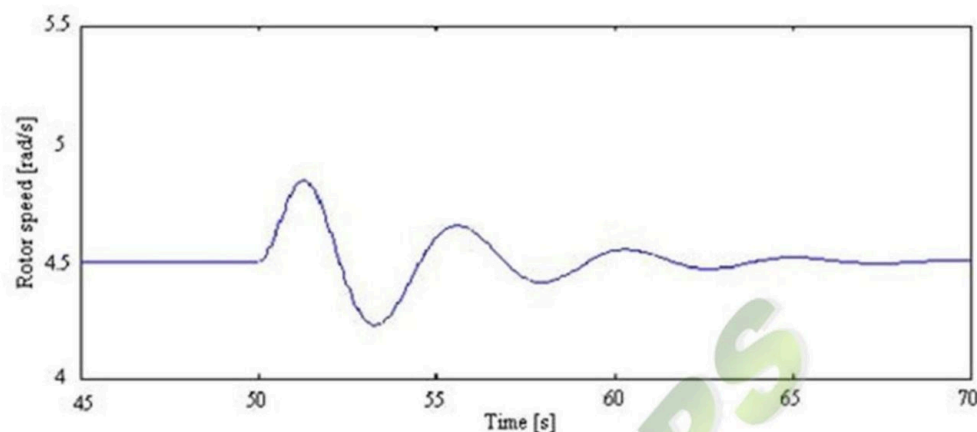

Figure 33: Rotor speed wind step response

After including the rotor model the rotor speed peak after a step change in disturbance is reduced to 4.85 rad/sec. Still the diff. pressure over the pump reaches 320 bar.

It is tempting to suggest a feed forward solution where the wind speed is measured. Then the transmission can start lowering the speed of the rotor before the rotor starts accelerating. The realism in such a solution is rather poor since wind speed measurements is challenging, and it is usually avoided as a parameter for fast regulating purposes.

Another way to reduce the rotor speed peak is to implement an over speed controller to the pitch regulator. The pitch regulator can increase the pitch angle when the speed exceeds a certain limit. Such a pitch regulator is further discussed in chapter 6.2.3. Alternatively the rotor maximum operating speed for the rotor can be reduced. A reduction in maximum rotor speed will lead to an efficiency drop for low wind speeds. For high wind speeds the rotor power would anyhow have to be restricted, and a reduction in rotor speed does not have to reduce the energy production at high wind speeds. But a reduction in rotor speed when operating at the maximum power would cause an increased rotor torque to compensate for the decreased rotor speed. Whether the increased torque can be tolerated is not known since the necessary rotor data is not available.

Tests in chapter 6.2 shows that the current secondary controller (displacement controller) can be used. The final secondary controller settings are listed in Table 5.

Controller	Kc	ti	td	b
PID	$1.0 \cdot 10^{-6}$	0.25	2	0.025

Table 5: Final controller displacement setting

6.2 Primary Controller realization

The primary controller has four major tasks

- Pitch regulation
- Determine rotor speed
- Over speed protection
- Power limiting

6.2.1 Pitch regulation

There is one best efficiency pitch setting for each TSR, ref Figure 17. If the TSR is known the pitch can easily be adjusted to its most efficient angle. There have been doubts on whether the wind speed gauge that originally is installed at the Vestas V27 is adequate for pitch regulating purposes. What we know is that the original control system uses this wind speed signal to recognize the cut in wind speed. The pitch angle in the original V27 is optimized by a search regime. The pitch is varied while the power output is being monitored and optimized. The time intervals for the original search regime are not known. A fast pitch controller based on the power monitoring approach has been tested with the Simulink model without convincing results. This method will be referred to as method 1. The flow chart for the search method used is illustrated in Figure 34. Further details on how this scheme was implemented can be seen in appendix 4.

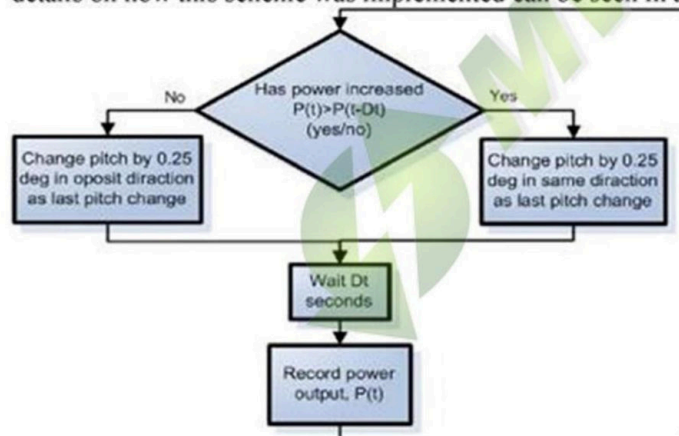

Figure 34: Pitch search flow chart, method 1

The efficiency of the transmission model is as mentioned in chapter 3.1 not accurate enough to be used uncritically as a reference when testing the turbine controller energy efficiency. The rotor model is likely more realistic. If the transmission operates under relatively constant conditions, whereas the transmission efficiency remains constant, changes in overall efficiency will mainly relate to changes in rotor efficiency. But the transmission leakage will also play a minor role since the momentum fluctuates with the wind speed and pitch angle. Despite that the pitch controller efficiency will be evaluated by comparing the generator energy production to a reference where the pitch at all time

are being maintained at the optimum setting, only restricted by a maximum pitching rate of 12 deg/s.

Method 1 was implemented and tested together with a constant rotor speed of 4.5 rad/sec and $\Delta t = 2.5$. The average wind speed was set to 12m/s. At this average speed both the output power and the hydraulic pressure operates around the maximum limit. For average wind speeds around 12 m/s and higher, the input power has to be restricted by increasing the pitch angle. When the power is being restricted there is no longer a need for the pitch searching regulator to optimize the pitch setting. An average wind speed of around 12 m/s is therefore the maximum wind speed where the pitch searching function would have to operate. Pitch regulation at this average wind speed represent the most turbulent normal operating condition for the pitch search controller since the wind speed standard deviation is proportional to the average wind speed, see chapter 3.3.

The pitch resulting from this scheme, method 1, is plotted in Figure 36. The green line shows the ideal pitch setting at any given time. The obtained pitch, the blue line, shows large deviations from the ideal pitch setting. Different pitch and time step sizes was tested without getting better results. The search scheme does not seem to sufficiently distinguish between power variations due to pitch, and power variation caused by change in wind speed. During a period of 1000 seconds this method of regulating the pitch resulted in a total power production equivalent to 98.1% of the energy that would be produced by the reference system with ideal pitch. 98.1% is better than what could be expected by looking at the sluggish pitch curve in Figure 36. A constant pitch angle of -2.5 degrees only produced 83.7% of the same reference energy. Still the correlation between the optimum pitch and the obtained pitch by method 1 is apparently absent.

An improved scheme was developed so the regulator better could distinguish between power changes due to pitch and wind change. This improved scheme (method 2) change the pitch back and forth at a given time interval. If the energy output changes correspondingly to given number of pitch change cycles, it is likely that the power changes come from pitch change rather than wind fluctuation. The number of pitch cycles that has to result in the same power output changes will determine the probability for the controller to do the right or wrong pitch correction. The down side of requiring a large number of cycles to give the same result before changing the pitch, is a slower pitch regulator. How the regulator is set up is a fine balance between quickness and how consistent the regulator will be. The flow diagram for method 2 is presented in Figure 35.

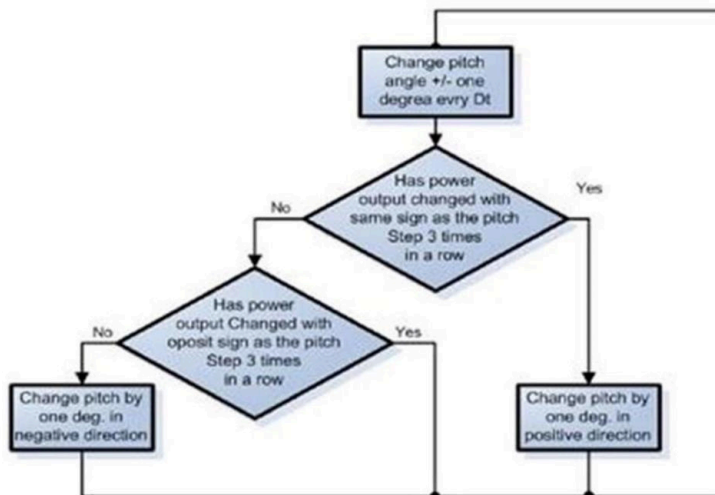

Figure 35: Pitch search flow chart, method 2

Pitch method 2, with $Dt=2$, results in a pitch that follows the ideal pitch significantly better than for method 1, se Figure 36. Figure 37 shows a zoomed view of how the two different methods follow the ideal pitch.

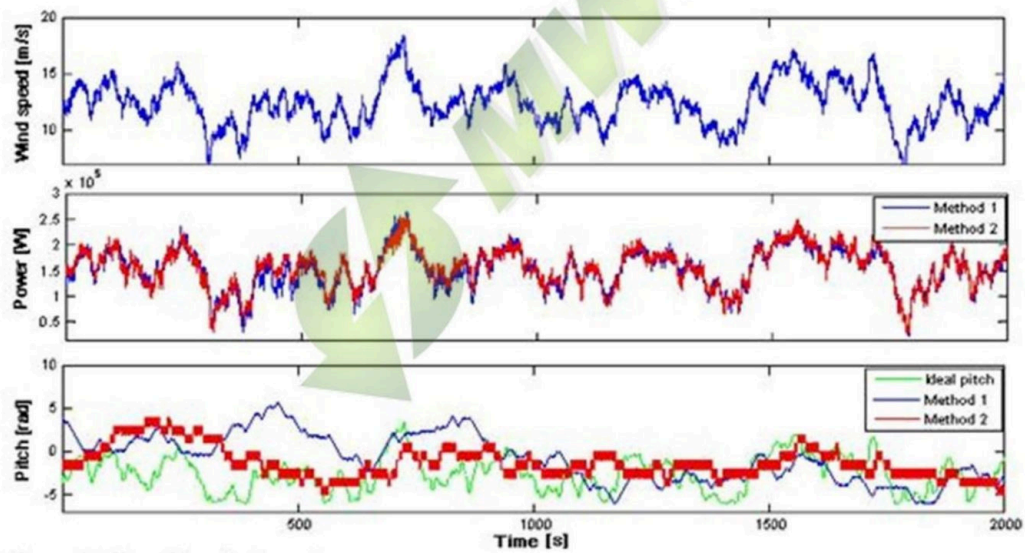

Figure 36: Searching pitch regulator

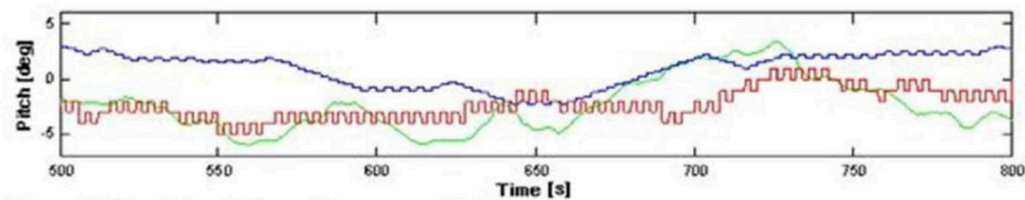

Figure 37: Searching pitch regulator, zoomed view

Method 2 produces 99.0% of the reference energy produced by the optimum pitch system. It is slightly more energy efficient than method 1, but even more important it follows the ideal pitch more consistently. This will minimize the chance of stall due to large errors in the pitch angle.

The model test indicates that it is possible to create a fast pitch regulator that searches for the best pitch. It is also likely that a more sophisticated method could improve this pitch controlling method additionally. It should be stressed that the frequency of the oscillating pitch under no circumstances should be equal to the natural frequencies of the turbine blades, moreover the rest of the system. If this proves to be a problem it is possible to oscillate the pitch with a changing time interval. It should also be noticed that this pitch regulator so far has been tested in an operating range where the rotor runs at constant maximum speed. For lower wind ranges the rotor will operate at variable speed. The speed variation could possible interact with the above mentioned pitch searching regime. How the developed method for pitch regulation works together with variable speed operation is tested in the next chapter.

Pitch regulation summary	
The pitch regulator varies the blade pitch back and forth a given number of times to confirm whether the pitch angle should increase or decrease to increase the power output.	
Pro	<ul style="list-style-type: none"> • Optimizes power output • Distinkts between change in power output due to wind change and pitch change • No wind measurement needed • Can provide information on effective wind speed • The method can be improved • Method can be implemented by looking at generator power fluctuations corresponding to oscillating pitch angle
Con	<ul style="list-style-type: none"> • Possibly resonance issue • Excessive wear and risk of fatigue when regulating fast • Real generator power output variations can be more difficult to interpret

Table 6: Pitch regulation summary

6.2.2 Speed regulation

It is difficult to decide the ideal TSR based on a wind gauge measurement. To obtain a reliable wind measurement the measurement has to be averaged over a certain time period [Burton T, et al., 2001]. The original Vestas 27 pitch system has a pitch regulator that “searches” for the best pitch angle. Change to a better pitch angle is confirmed by increasing generator power output. This way the pitch system is maximizing the power production at a constant rotor speed. If the best pitch angle is found by the pitch regulator, the actual TSR can be extracted from Figure 38. The figure shows the relation

between the best pitch and the TSR. For pitch angles below 0 there are two corresponding TSR for every best pitch angles. According to Equation 27 the TSR will not exceed 6.7. The limit is marked by a red line in Figure 38. The turbine will ideally operate at the left side of the red line. At this side there is only one unique TSR for every best pitch angle.

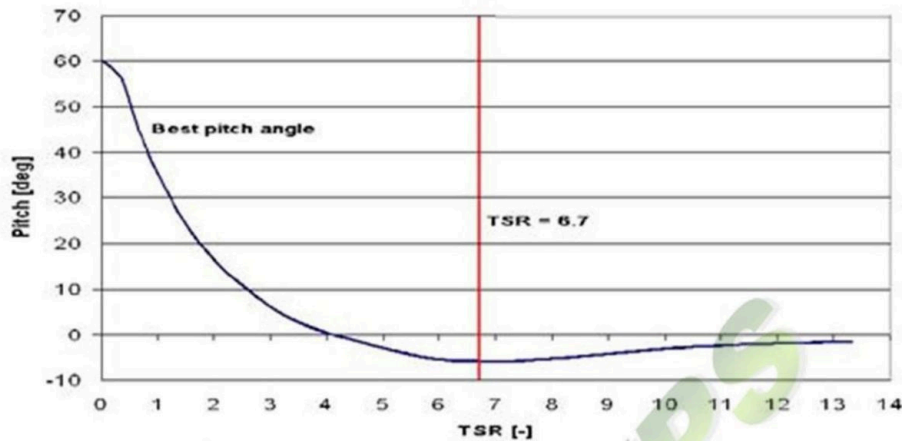

Figure 38: Best pitch angle

When the actual TSR and the rotor speed are known the wind speed can be interpreted. The interpreted wind speed will together with Equation 27 give the optimal rotor speed for the actual wind speed, and the rotor speed will function as a reference speed for the transmission controller. If following the optimum TSR the rotor will reach its maximum speed at wind speeds above 9.1 m/s. If the wind over some time is measured to be considerably higher than this limit the rotor speed can be set to a constant value of 4.5 rad/s. This will prevent the wind speed estimation method to interfere with pitch changes due to power restriction.

The red line in Figure 39 shows a plot of the reference speed produced by the above mention method. The blue line illustrates the best possible rotor speed according to the optimum variable TSR. The wind in this case has an average wind speed of 6.7 m/s and a wind speed variation of 0.2. It should be stressed that there for this first test of this method is no real pitch search function implemented in the Simulink model. The search function is for this test approximated by the optimum pitch angle multiplied with a first order transfer function with a time constant of 10 seconds. This means that the pitch angle after a sudden change in wind speed uses 10 seconds to reach 63% of the total pitch change it will have to perform in order to reach the new best pitch angle. Tests in chapter 6.2.1 have shown that such a time constant can be realistic.

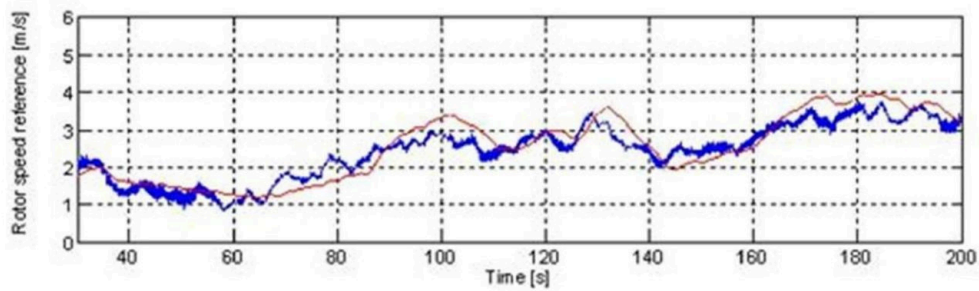

Figure 39: Rotor speed reference

The turbine should refer to Equation 27 ideally operate at TSR below 6.7. However if the wind suddenly decreases the TSR could exceed 6.7. Now we are in a situation where the controller believes the TSR is lower than 6.7 since the pitch controller decreases the angle and adapts to the higher TSR, see Figure 38. Since the controller registers a drop in TSR while the rotor speed is not correspondingly decreased, it will believe the wind has increased and it will increase the rotor speed. The operation of the turbine will now move even further to the right in Figure 38 and the situation can be considered as a vicious circle. The best pitch angle/TSR relation in Figure 38 is not strictly decreasing nor strictly increasing, and one best pitch angle can refer to two different TSR. Figure 40 illustrates how a pitch angle of -3 deg could indicate operation at a TSR of 5.4 or 9. With a rotor speed of 4 rad/s the two TSR corresponds to wind speeds of respectively 10 m/s and 6 m/s. Which of them that is the right one is decided even by an inaccurate wind speed gauge.

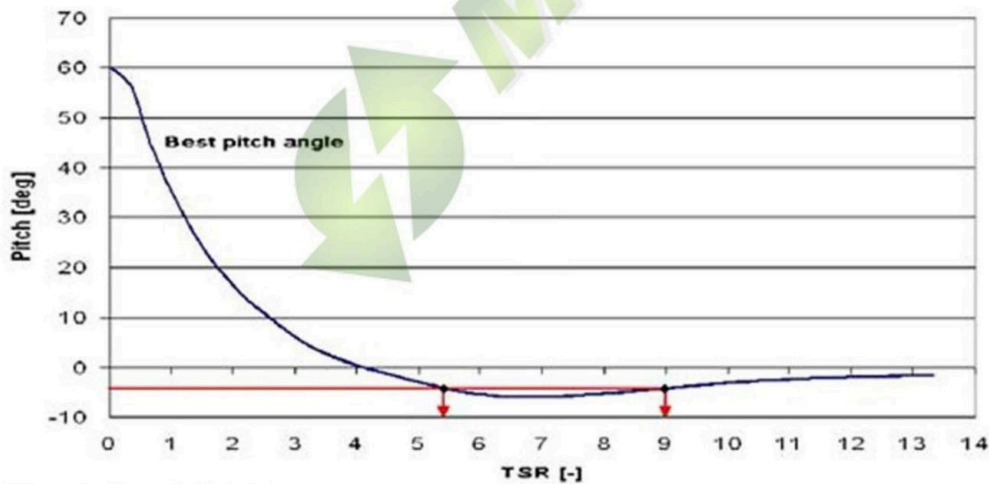

Figure 40: Best pitch angle

This solution can be implemented by using two lookup tables to find the current TSR. One table can be used for the left part of Figure 38 and another table can be used for the right part. Primarily the right side of the table will be used, since this corresponds to the efficient way of running the turbine, ref Equation 27. If the TSR for some reason should increase above a certain limit the controller can simply switch to using the second table. The limit for the switching could be set slightly higher than $TSR=6.7$. Switching between

the two tables will only occur caused by severe drop in effective wind speed. This switching can be controlled by a wind measurement device. Even if such a device is exposed to severe turbulence it is possibly sufficient to monitor a wind drop by this magnitude. Figure 41 illustrates how this is implemented in the Simulink model.

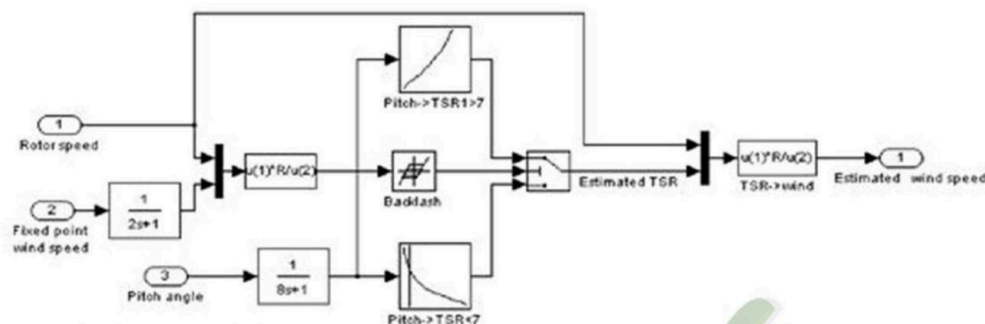

Figure 41: Wind speed estimator

Figure 42 shows how the combination of two lookup tables gives a good approximation of the current TSR. The blue line is a plot of the real TSR. The red line is the result from the lookup tables. The sudden step in estimated TSR is a result of switching between the two tables. To provoke this situation the wind speed variation was set to 0.3, which is relatively high.

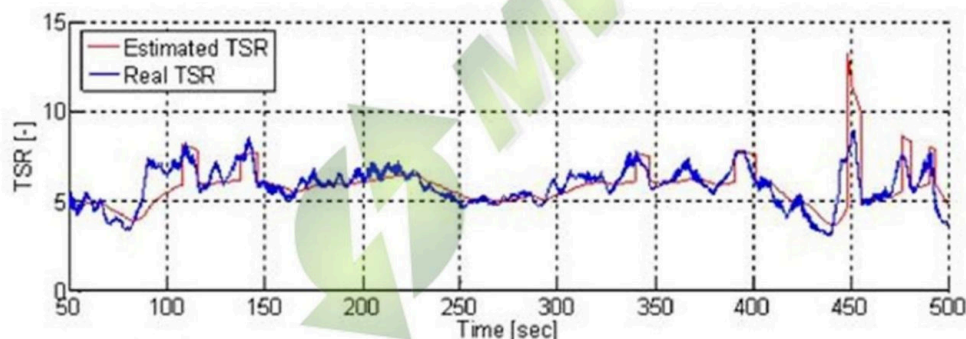

Figure 42: Estimated TSR

The TSR-controller will now use the estimated TSR to set the rotor speed reference. Further this method of setting the rotor speed is tested together with the pitch regulator in a wind range where the rotor operates with variable speeds. Now the power output will be affected by the wind speed, the pitch angle and the additional variation in rotor speed. Some minor adjustments had to be made to the pitch controller in order for it to cope with these new interactions. So far improvements in power output have been recognized by comparing two power output values at their respective pitch settings. In stead of using the output power as an indicator of whether the power is increasing or decreasing the power gradient is being used. The power gradient at the respective pitch settings is monitored. As seen in Figure 43 this proved to work quite well together with variable rotor speed operation. The power output pitch response will differ depending on how the turbine operates, and there is a major difference from high wind speeds when the turbine is operating at constant rotor speed and for low wind speeds and variable rotor speed. Thus

it could be necessary to use different methods for pitch searching depending on the wind speed.

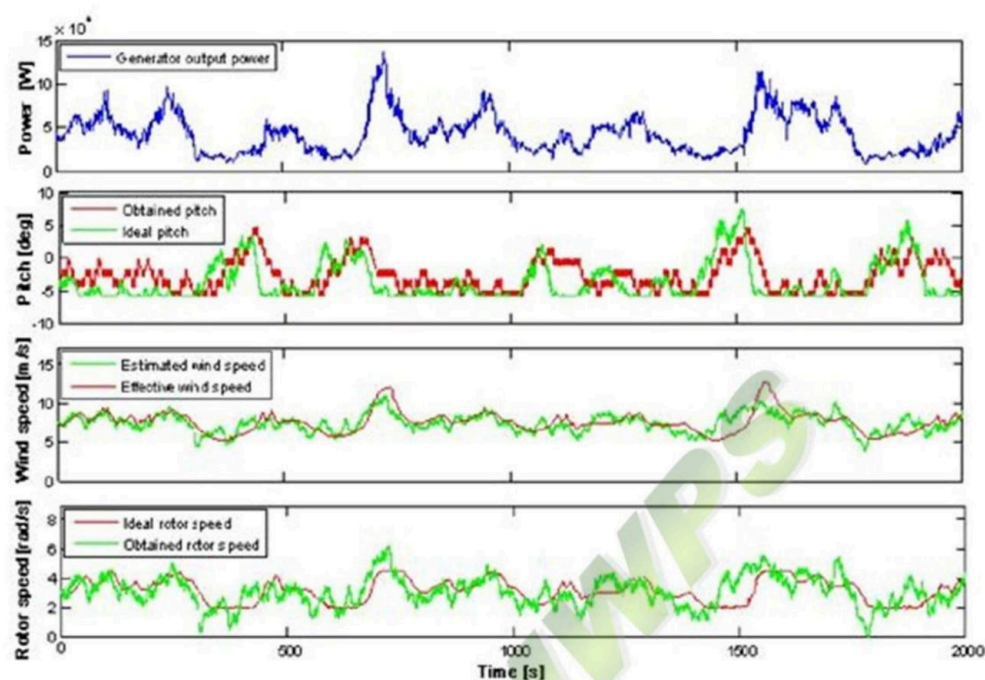

Figure 43: Speed and pitch regulator, average wind speed of 7.5 m/s

From Figure 43 it seems like the rotor speed follows the optimum speed resulting from the optimum TSR quite well. How the rotor speed varies according to the wind speed is shown in Figure 44. The red line illustrates the optimum TSR. In Figure 45 the efficiency chart is placed on top of the scattered plot to illustrate how the rotor speed operates relatively to the best possible efficiency.

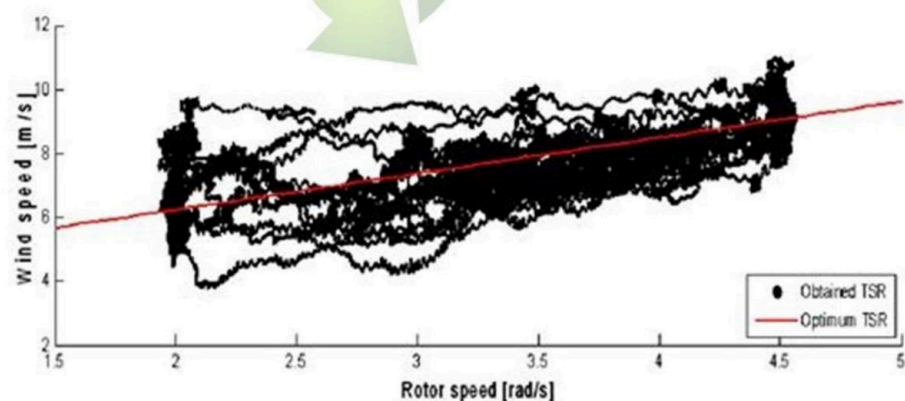

Figure 44: Rotor speed vs. wind speed

The efficiency chart is taken from Figure 21. From this figure it is clearer how far away the turbine speed is from the best efficiency. Still the aims of this test is to see how closely

the turbine follows the specified speed setting, which is marked with a red line in Figure 45.

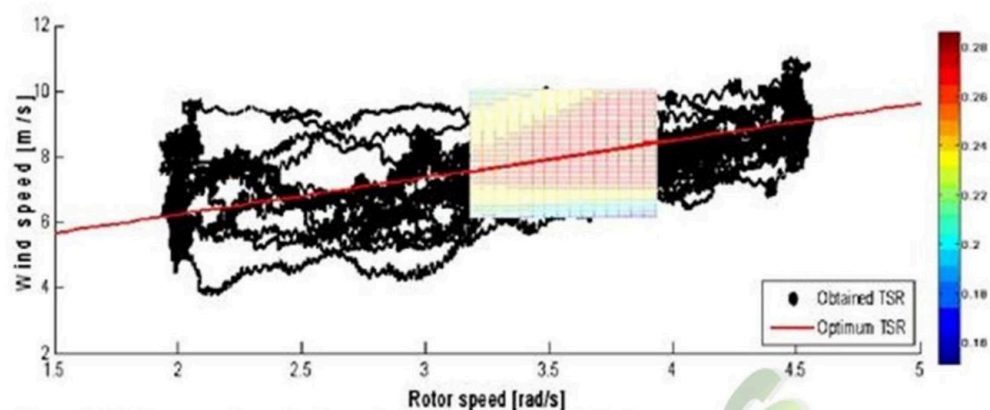

Figure 45: Rotor speed vs. wind speed on top of efficiency chart

The scattered plot of the obtained TSR shows a relatively large deviation from the optimum TSR. How this effect the power production is difficult to foresee without having a complete efficiency chart of the wind turbine. If the efficiency chart has a sharp best efficiency edge, a sluggish TSR regulation could have severe consequences for the total power production. If another area of the efficiency chart has a flatter efficiency curve it could be beneficial to operate in this area, even if the peak efficiency is higher in other parts of the operating range.

The scattered TSR points indicates a better regulation for high rotor and wind speed, and a less precise regulation for low rotor and wind speeds. This has been confirmed by tests over a longer time period. The different accuracy for low wind and rotor speed, and high rotor and wind speeds are related to how the wind speed is found based on the pitch angle. As seen in Figure 43 the obtained pitch angle lags behind the optimum pitch angle. Also switching between the best pitch table for low TSR and high TSR will cause a step in the estimated wind speed. These are the two main factors.

It must be mentioned that a variable step size solver has been used to simulate the rotor speed. And even if the time steps are relatively constant there is not a direct relation between the number of scattered points and the time of operation at this area of the wind speed rotor speed plane.

The variable pitch and speed regulation is based on power readings from the generator. The wind turbine model does not include the generator dynamics beyond the inertia and a linear torque curve, and the power output is assumed to be identical to the generator driveshaft power. In a real wind turbine the generator power signal will be provided based on current and voltage signals. These signals could vary from the modeled output power, and the pitch searching regime will have to be tuned to handle these differences.

Speed regulation summary	
The rotor speed regulator is set to regulate the rotor speed according to a defined variable TSR. Alternatively the ideal rotor speed relatively to the wind speed can be given in tabular form. The wind speed can be found based on the pitch regulator	
Pro	<ul style="list-style-type: none"> • No need of accurate wind gauge measurement • Wind speed based on the best pitch angle represents the effective wind speed acting on the blades, and not a random wind speed at one fixed point • The method will be improved if the best pitch/TSR curve is steeper, meaning that a change in TSR results in larger change in pitch angle than what is predicted
Con	<ul style="list-style-type: none"> • Unconventional method which requires further development and excessive testing • Requires accurate data on the relation between the most effective pitch angle and the TSR • Method can fail if the best pitch/TSR curve is flat for a wide TSR range • Will always be slower than the pitch regulator • Switching between finding the wind speed based on best pitch/TSR table for high or low TSR can be problematic

Table 7: Speed regulation summary

6.2.3 Over speed pitch control (OSPC)

The purpose of the OSPC is to reduce the rotor torque as rapid as possible if the rotor speed exceed a given limit. This is achieved by increasing the pitch angle of the rotor blade. The positive change in the pitch angle is done by the maximum pitching speed of 12 deg/sec. When the rotor speed is reduced below the given limit, the controller pitches the blades back to the pitch setting given by the main pitch controller. This is done with a reduced pitch speed of 1 deg/sec. This way a rapid torque increase and a new “over speed” are avoided.

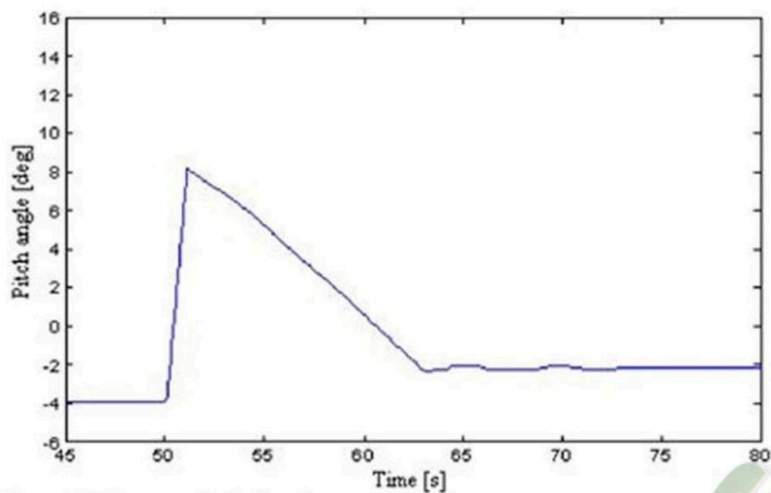

Figure 46: Over-speed pitch action

The OSPC was implemented in the model and was tested with a step input in wind speed. The step goes from 6.56 m/s to 12.7 m/s and is applied after 50 seconds. Figure 46 Shows how the over speed control increases the pitch by the maximum possible rate of 12 deg/sec. The blades are being pitched back slightly after the turbine reaches its speed peak. The de pitch action shown in Figure 46 is a result of the over speed caused by the same step in wind speed as in chapter 6.1.3 where the disturbance response was tested. The torque reduction effect caused by the over-speed control is shown in Figure 47. The red line illustrates the turbine drive shaft torque without an OSPC.

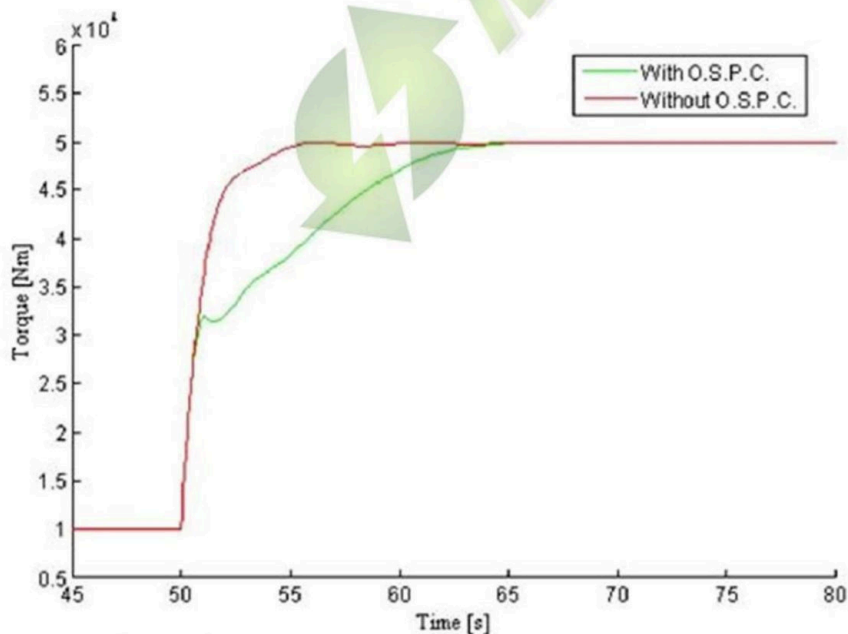

Figure 47: Over-speed torque impact

Even with such a reduction in rotor torque the rotor speed reaches 4.8 rad/sec, see Figure 48. The improvement gained by including the OSPC is only 1% reduction in the speed peak value.

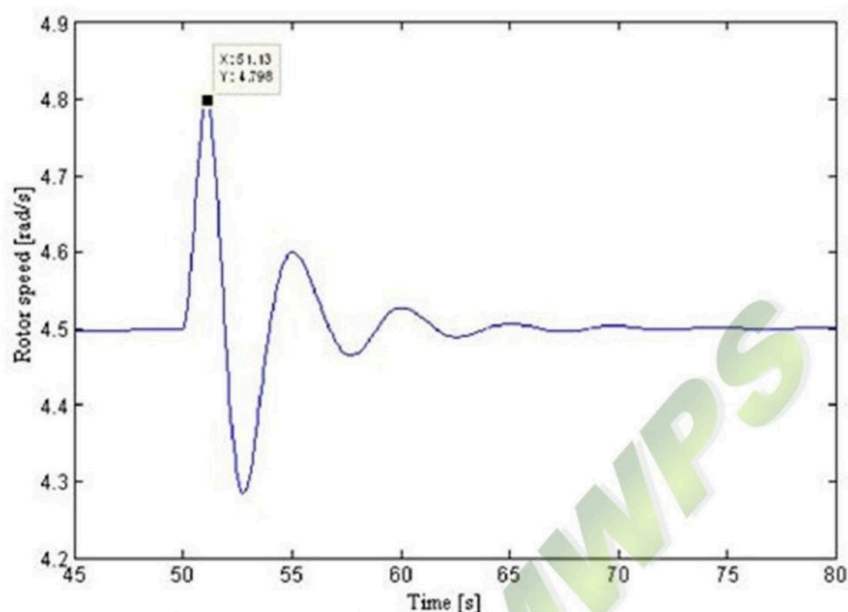

Figure 48: Rotor speed step response

The rated speed of the turbine is 43 rpm or 4.5 rad/sec. Unfortunately there is no available information regarding the safety margin of this speed limit. As mentioned in chapter 4.2.1 it is likely to assume that the turbine can withstand some over speed for a short period of time.

This OSPC was implemented and tested together with variable pitch and variable speed operation with extreme turbulent wind conditions. The wind speed standard deviation was set to 0.5. This resulted in turbulent wind speeds changes from 16 to -4. The average wind speed was 7.5 m/s. Under these conditions the OSPC managed to restrict the maximum rotor speed peak to 4.6 rad/s. Under the same conditions without the OSPC the maximum rotor speed peak reached 4.75 rad/sec. The OSPC manage to reduce the rotor speed peaks magnificently, and an over speed reaching 4.6 rad/sec, lasting a tenth of a second is most likely acceptable.

For normal wind conditions the rotor speed does not exceed 4.6 rad/sec even without the OSPC.

An over speed peak of 4.6 rad/sec under unlikely conditions is most likely acceptable. If not the maximum rotor speed must be reduced by 0.1 deg/s to a resulting maximum speed of 4.4 deg/s.

OSPC summary	
The Over Speed Pitch Control increases the pitch angle when the rotor speed exceeds a given limit. The pitch is changed back to the pitch regulator setting at a slow rate to prevent a new over speed.	
Pro	Effectively prevents excessive over speed
Con	Must change pitch angle at high rate to be effective

Table 8: OSPC summary

7 Discussion

Model

The wind turbine model was consciously simplified in order to get a model which is easy to understand and work with. The basic model make it easy to do changes and test new ideas. When using the model it is important to be aware of the simplifications made. The rotor blades and the tower is treated as a rigid system without the possibility of flexing, and phenomenon such as oscillation and resonance will not occur and affect the system. The rotor torque is found based on C_p data for the rotor combined with an effective wind model. The wind model includes the filtering effect caused by the large swept area of the rotor, it includes rotating sampling effect and it partly substitutes for the damping effect caused by blade elasticity. The rotor will not be exposed to wind shear and the cyclic torque pulsation caused by wind shear is neglected. Time delay caused by the oil pressure propagation speed is neglected, and issues related to pressure shock waves is not evaluated. Generator electronics has not been modeled and the power output of the generator is assumed to be equal to the generator driveshaft power. This simplification makes it impossible to fully evaluate the power quality.

Even if the model is simplified it represents the most important features of the system such as rotor efficiency based on wind speed, rotor speed and pitch angle. The model includes rotor and generator inertia, hydraulic oil compressibility, generator torque and to some extent transmission efficiency. Since the most important features is maintained the wind turbine model shows convincing results, and no remarkable dynamical behaviors has been noticed. Referring to Peter Chapple the transmission damping and natural frequency is similar to his simulations. Despite of that the energy efficiency of the model is quite different from the energy efficiency found when testing the prototype, and the model can not uncritically be used for measurements of energy efficiency.

The inaccuracy of the wind turbine model can easily be seen in Figure 49 where the real efficiency plot from Figure 21 is put on top of an equivalent plot made based on the Simulink model. The error in the model comes from simplifications of losses in the transmission. Losses in the transmission are to a large extent made linear or constant. That makes losses in the transmission model more constant than for the real transmission.

The rotor model efficiency is relatively accurate and will vary more than the transmission model efficiency. This can be seen in Figure 49 where the model chart has a best efficiency corresponding to a TSR=8, marked with the red line. This is also the best TSR for the rotor efficiency, and it can be concluded that the wind turbine model efficiency is dominated by the rotor characteristic.

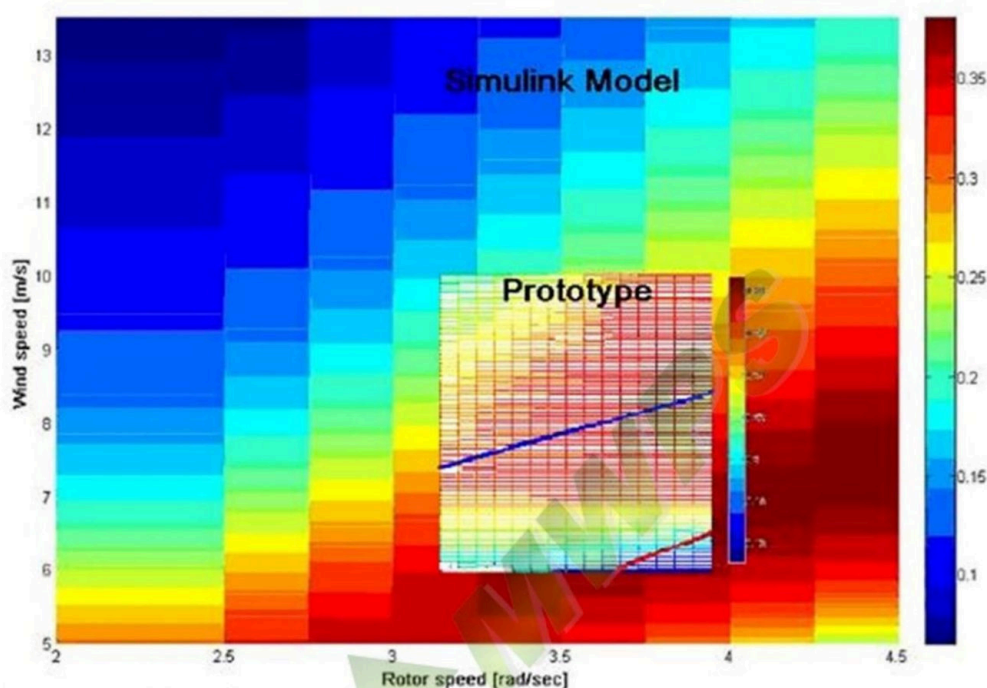

Figure 49: Model efficiency vs. real prototype efficiency

Control strategy

The control strategy is based on a maximization of the overall energy efficiency. How the efficiency varies is found based on calculated C_p values for the rotor and prototype test results for the transmission. The estimation accuracy will be dependent on the accuracy of the C_p value and the transmission prototype tests. There are also performed some linear interpolations of the transmission test data that will affect the efficiency in between the points where accurate test data are known. This can be seen as three distinctive breaks in the surface of the efficiency plotted in Figure 20. The efficiency could only be estimated for a restricted wind turbine operating range, since tests of the transmission prototype only covers a limited part of the transmission operating range. For this limited range an efficiency plot can be made in the rotor speed-wind speed plane. The plot indicates that the rotor should operate with a TSR linearly dependent of the wind speed, see chapter 4.1. If this is the optimal solution depends on the characteristics of the unknown efficiency for the rest of the rotor speed-wind speed plane and the regulator quality. If a controller for instance is extremely sluggish when maintaining a given TSR, it could be beneficial to operate the turbine in a part of the turbine wind speed plane where the efficiency curve has a lower efficiency but is flatter and has. Operating in a

range where the efficiency plane is flatter would make the resulting efficiency more forgiving to poor TSR regulation.

The real time TSR can easily be controlled if the wind speed can be measured. The wind speed could possibly be found many ways, and the different methods should be considered before a final solution is chosen. Some examples on how the real time TSR can be found are; improved wind gauges in hub height, pitot tube in rotor hub, angle of attack measurements on the rotor blades, and blade resultant force direction measurement. Another possibility is described in chapter 6.2.2. This method is based on the fact that every TSR has one optimum pitch setting. The best pitch setting is found by a pitch searching regime where the generator power output is monitored. The pitch setting is changed to optimize the power output. If the optimum pitch setting is found, the current TSR can be derived based on the best pitch angle.

Control realization

The secondary transmission displacement controller is realized by a PID controller. The controller is tuned based on the dynamics of the model. If important features such as inertia, effective bulk modulus or damping effects are considerably different for the physical wind turbine, the controller could have to be re-tuned, even if the controller set up with a considerably large gain and phase margin. The change of reference speed input to the controller is damped. A damped reference will naturally result in a poorer speed reference response, but is strictly necessary to avoid excessive hydraulic pressure. A damped reference will not affect the capabilities of maintaining constant speed with disturbance in form of wind speed. The controller effectively manages to maintain a constant rotor speed during severe wind speed fluctuations.

The pitch regulator was realized based on a search regime where the pitch angle is changed to obtain the most efficient angle based on the generator power output. How this search regime is developed must depend on how the generator power fluctuates related to cyclic blade pitch change. The model is simplified and the real generator output power characteristic can turn out to be quite different from the model. If this is the case it could be necessary to adjust the search regime. The regime could be adjusted by producing generator power time plots corresponding to pitch oscillations from the physical modified wind turbine.

The rotor speed regulator is based on the result of the pitch regulator. This way the speed regulator can operate without an accurate wind speed gauge. The most efficient pitch angle varies with the TSR, and a table containing this information can be used to interpret the unknown wind speed. This best pitch-TSR relation is not strictly increasing or decreasing, and the same pitch angle can be the most efficient for two TSR. A wind speed indication decides which of the two TSR readings that represents the correct one. If the two TSR readings are close to each other the inaccurate wind speed gauge is not able to decide which of them that is the correct one and it could end up switching between the two solutions, see Figure 40. If the two TSR readings get more dissimilar it is easier to decide which of them that is the correct one, based on an approximate wind reading. How effective this method is will depend on where in the TSR range the operation will occur and how the real best pitch curve looks like. The speed control quality is also strictly dependent on the quality of the pitch controller. Alternative methods of how to switch between the two tables has not been discussed in the project. It is possible that the power

output or the rotor torque could be a better way of doing this. Alternatively a combination of different parameters could be used.

8 Conclusion

Despite of the limited transmission efficiency data the traditional wind turbine control strategy including operation at a constant tip speed ratio is rejected. Calculations clearly show that the transmission efficiency is affecting how the wind turbine should be operated. An example of a more effective way of operating the turbine has been described. If this is the most energy efficient method of operating the turbine depends on the transmission efficiency beyond the tested range. There are in other words are doubts regarding how the TSR and the rotor speed should vary with different wind speeds, and the model can not be used to test the overall efficiency due to its inaccuracy.

The controller developed in this project can effectively control the rotor speed at a constant value. For large wind fluctuations the rotor speed can increase slightly before the controller manages to compensate for increased oil compression, leakage and generator speed. If a wind gust results in rotor speed over shoot above the rated speed, the blade pitch can be used to reduce the torque and thus the resulting over speed peak effectively.

Model tests shows that the secondary transmission controller effectively manages to maintain a fixed rotor speed according to a given reference. The controller also manages to change the rotor speed according to changes in the reference speed, except when the reference speed is changed too rapidly. If the reference speed is changed too rapidly the mechanical load on the transmission becomes unacceptable. Rapid reference changes are avoided by a filter which dampens the reference signal to an acceptable change rate. Further model tests should be performed in order to confirm that the transmission prototype can handle the given regulator settings. These tests should include a more accurate transmission model.

How the controller in the end manages to maintain a specified TSR is primarily dependent on how the controller can get information on the wind speed. Measuring the wind speed with a wind gauge is possibly difficult. An alternative method on how to measure the wind based on the optimum pitch setting has been described.

The idea of a rotor speed controller based on the pitch angle has shown promising results, and the method has proved to be a possible method of realizing an energy effective control strategy without having an accurate wind gauge measurement. The variable pitch and rotor speed control model tests has shown good results taking in to account that it has not been made attempt to improve the concept further. The quality of the primary controller can most likely be improved if power fluctuations caused by pitch oscillation is studied. Implementation of such a control system would anyhow require changes to the controller since the modeled generator power will differ from the real generator power.

9 Further work

There are two major topics that I would like to point out for further progress on the development of a wind turbine controller for the modified Vestas V27. First it should be made clearer how the wind turbine should be operated from an energy efficiency perspective. Secondly a method of sampling the real time TSR should be developed. This could be achieved by further development of the solution described in this project. But different alternatives should be compared before a final decision is made.

The described method of finding the current TSR has shown promising results. The method should be improved, and further testing should be performed to reveal possibly hazardous failure modes related to it.

If continuing this work it would be natural to improve the model until it shows the same efficiency characteristics as the prototype. Then the model can be used to test which TSR that shows to be most efficient at different wind speeds. The model can easily be changed if there are made any modifications to the system. The reliability of the results will depend on the quality of the model.

The optimal TSR for each wind speed can also be tested in situ. The results of such a test will depend on how closely the controller manages to follow the given TSR that are tested. To get reliable results it is important that the TSR controller used during these test is the one being used later on. If there are made any changes to the transmission, the wind gauge, or the displacement controller, the test ideally has to be performed over again. This is one of the major disadvantages of this way of finding the most energy efficient control strategy. The advantage is the reliability of the results.

References

Balchen Jens G., Andresen Trond, Foss Bjarne A., *Reguleringsteknikk*, 5th edition, Trondheim, Norway, NTNU-Trykk, 2004

Burton T., Sharpe D., Jenkins N., Bossanyi E., *Wind Energy*, John Willey and Sons Book Company, Chichester, England, 2001

Chapple P. J., *Summary of test data*, Marienborg tests, Trondheim, 2007.

Goodwin A. B., *Fluid power systems*, East Kilbride, Schotland, Thomson Litho Limited book company, 1979.

Haugset S. K., *Wind turbine design*, Master thesis, NTNU, Trondheim, 2007

Leithead W., Connor, B., *Control of variable speed wind turbines*, Internal Journal of Control 73(13), 1189-1212, 2000

Pettersen O. J., *Modelling and simulation of wind turbines*, Master thesis, NTNU, Trondheim, 2007.

Petru, T. and Thringer, T., *Modeling of wind turbines for power system studies*, IEEE Transactions on Power Systems 17(4), 1132–1139, 2002

Bianchi D. F., De Battista H. and Mantz R. J., *Wind Turbine Control Systems*, Springer-Verlag, London, 2007

Seborg Dale E., Edgar Thomas F., Mellichamp Duncan A., *Process Dynamics and Control*, second edition, Danvers, USA, Wiley book company, 2003

Varpe S. A., *Field measurements on a wind turbine*, Project work, NTNU, Trondheim, 2007

Appendix

List of contents	
Appendix 1	Hydraulic transmission test data
Appendix 2	Simulink model constants
Appendix 3	Simulink model block diagram
Appendix 4	Pitch search functions
Appendix 5	Effective wind model filters

Appendix 1: Hydraulic transmission test data

Test data					
1000rpm. gen. speed					
Displacement	Power input(pump)	Pipeline pressure drop	Pressure Drop/Q	Q,leak/delta P(pump)	Q,leak/delta P(motor)
97 %	37.4131	10.1580	0.0196	-7.0190E-13	1.3511E-10
	55.4808	9.7550	0.0187	4.4529E-12	8.6293E-11
	73.0807	9.5220	0.0182	7.4084E-12	6.4153E-11
	92.6628	9.9570	0.0189	9.5539E-12	5.0997E-11
	109.3235	10.0760	0.0191	1.0626E-11	4.3950E-11
	129.2802	10.0440	0.0189	1.1421E-11	3.8373E-11
	148.7458	10.3760	0.0196	1.2164E-11	3.4116E-11
	167.1841	10.3750	0.0196	1.2603E-11	3.1274E-11
	184.8131	10.2670	0.0194	1.2968E-11	2.9029E-11
	205.4175	10.3230	0.0194	1.3466E-11	2.7519E-11
	225.2044	10.0370	0.0189	1.3874E-11	2.6352E-11
	244.9786	10.0110	0.0189	1.4599E-11	2.5437E-11
	90 %	32.5381	8.9640	0.0189	-1.3721E-13
49.5637		8.9420	0.0189	5.2165E-12	5.6232E-11
65.3907		8.6280	0.0181	7.4888E-12	4.3782E-11
80.6871		8.3830	0.0176	8.8214E-12	3.6690E-11
97.8427		8.0140	0.0168	9.9781E-12	3.1714E-11
113.4485		8.0260	0.0168	1.0793E-11	2.8768E-11
132.3826		7.9840	0.0166	1.1415E-11	2.7044E-11
150.3825		7.9140	0.0164	1.2311E-11	2.5386E-11
169.4016		8.0050	0.0165	1.2977E-11	2.4058E-11
187.3270		8.7050	0.0178	1.3879E-11	2.3418E-11
207.3351		7.6290	0.0156	1.5047E-11	2.2892E-11
224.4085		7.7600	0.0159	1.5794E-11	2.2413E-11
82.50 %		27.5892	8.3710	0.0197	6.1124E-12
	42.2663	7.8930	0.0184	8.2982E-12	2.9655E-11
	57.1049	7.6020	0.0177	9.4782E-12	2.4674E-11
	72.4712	7.3840	0.0171	1.0493E-11	2.1393E-11
	86.9951	7.1550	0.0166	1.1047E-11	1.9635E-11
	102.4016	7.1400	0.0165	1.1585E-11	1.8780E-11
	118.1687	7.1590	0.0165	1.2145E-11	1.7825E-11

[Varpe S. A., 2007]

Appendix 2: Simulink model constants

```
1 - lambdap=1.2*10^-11; %Pump leakage coefficient
2 - lambdam=2.5*10^-11; %Motor leakage coefficient
3 - Vo=0.085; %Total high pressure side volume
4 - Bu=15*10^8; %Effective Bulk modulus
5 - Dp=1.8*10^-3; %Pump displacement volume
6 - alpha=130*10^-6; %Pipeline pressure drop coefficient
7 - Tgen=1000; %Nominal generator speed
8 - Jt=30000; %Rotor and pump inertia
9 - Jg=15; %Generator and motor inertia
10 - nablam=0.935; %Motor efficiency
11 - nablamp=0.945; %Pump efficiency
12 - t1=Vo/(Bu*lambdap); %Rotor and pump time constant
13 - t2=J2/(Tgen); %Generator and motor time constant
14 - krpm=(1000*2*pi/60); %Generator torque gradient
15 - b=nablam/Tgen; %Konstant
16 - a=1/lambdap; %Konstant
17 - c=krpm/b; %Konstant
18 - R=13.5; %Rotor radius
19 - d=nablam/J2; %Konstant
20 - a1=0.4; %von Karman spectrum model constant
21 - a2=0.25; %von Karman spectrum model constant
22 - Lv=180; %Experimently, on site, obtained von Karman spectrum model constant
23 - Um=8; %von Karman spectrum model constant
24 - Tv=Lv/Um; %von Karman spectrum model constant
25 - Tv1=Tv*a1; %von Karman spectrum model constant
26 - Tv2=Tv*a2; %von Karman spectrum model constant
27 - Kv=sqrt(2*0.762195122*Tv); %Rotational sampling effect constant
28 - Tsd=0.16; %Turbulence standard deviation
29 - D=0.12+0.00134*Um; %Rotational sampling effect constant
30 - Fco=0.325+0.0034*Um; %Rotational sampling effect constant
31 - n=43; %Rotational speed
32 - W=2*pi^3*n/60; %Rotational sampling effect constant
```

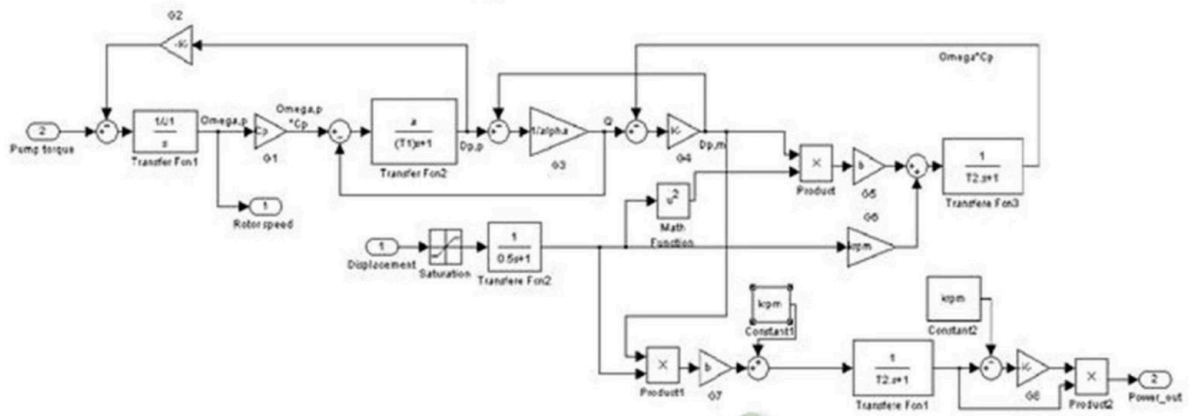

Transmission and generator model

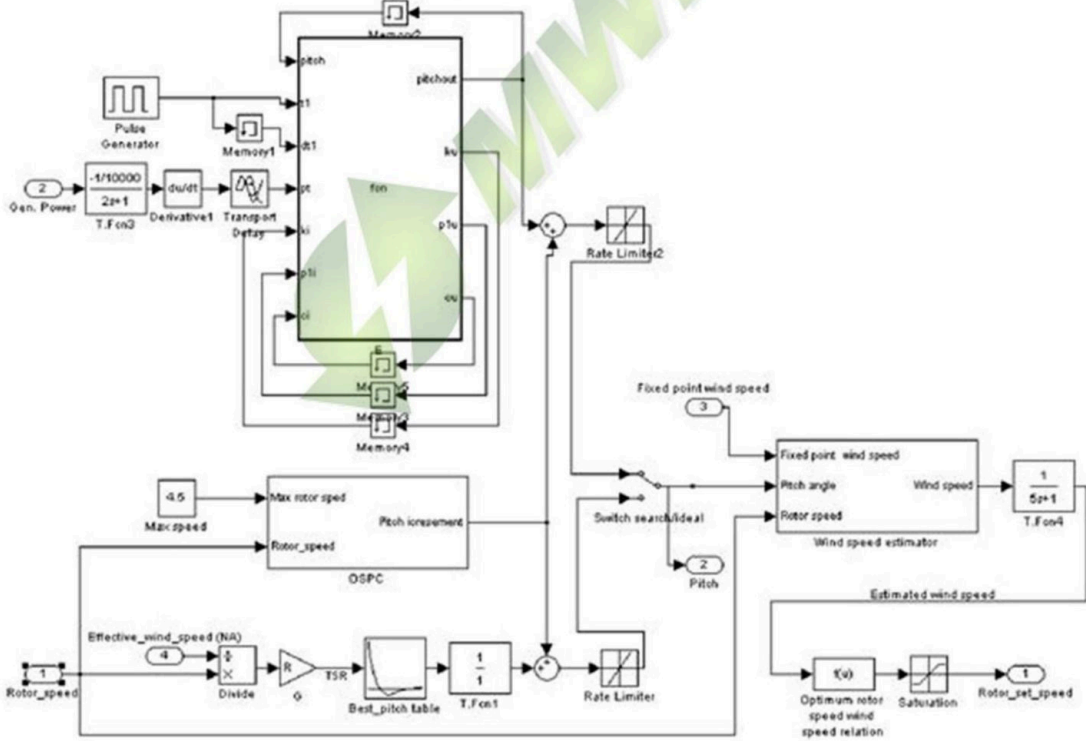

Primary controller

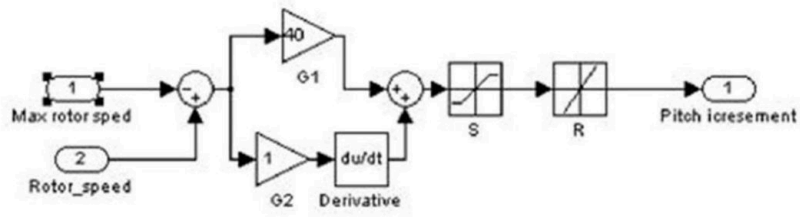

OSPC



Wind estimator

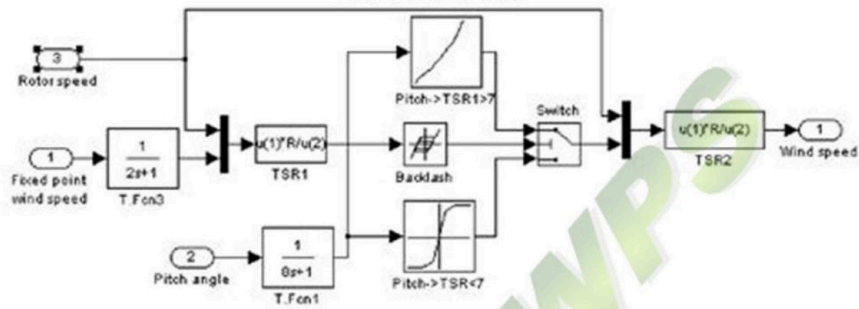

Secondary controller

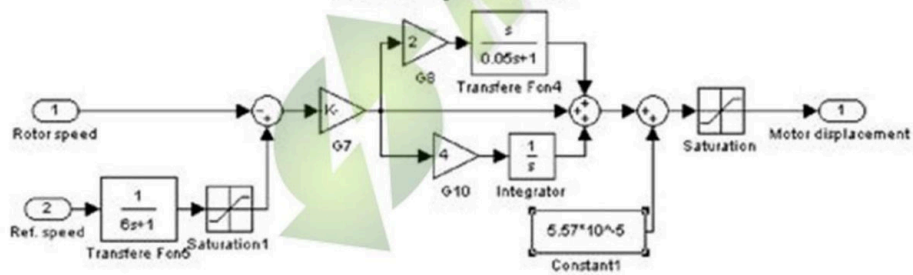

Appendix 4: Pitch search functions

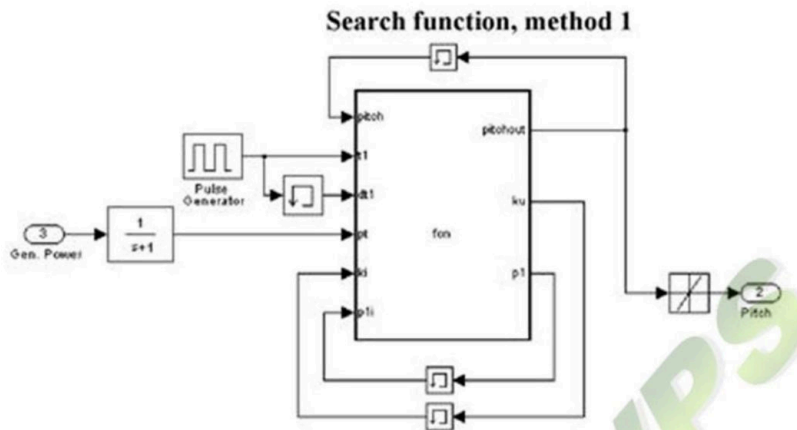

Matlab script, searching function, method 1

```

1  function [pitchout, ku, p1]=fcn(pitch, t1, dt1, pt, ki, p1i)
2
3  - ku=ki;
4  - pitchout=pitch;
5  - p1=p1i;
6
7  - if t1 > dt1 || t1 < dt1
8  -     p1=pt;
9  -     if pt<p1i || pt == p1i
10 -         pitchout=pitch+(0.25*-ki);
11     else
12 -         pitchout=pitch+(0.25*ki);
13     end
14
15 -     if pitchout>pitch
16 -         ku=1;           %Last change was positive
17     else
18 -         ku=-1;        %Last change was negative
19     end
20 end
21 - if pitchout < -6
22 -     pitchout = -6;
23 end

```

Matlab script, searching function, method 2

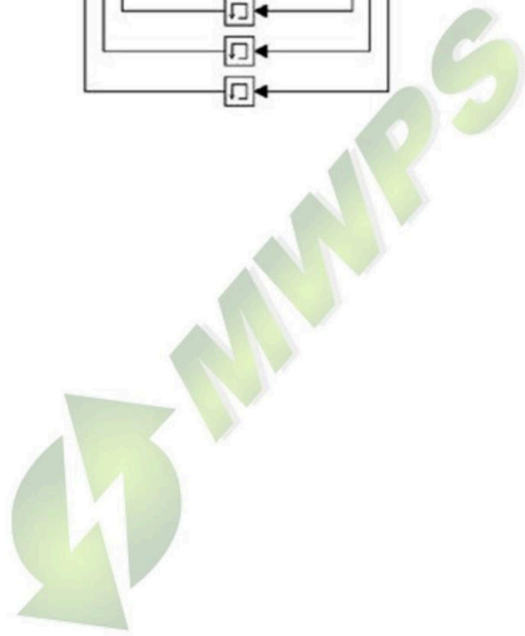
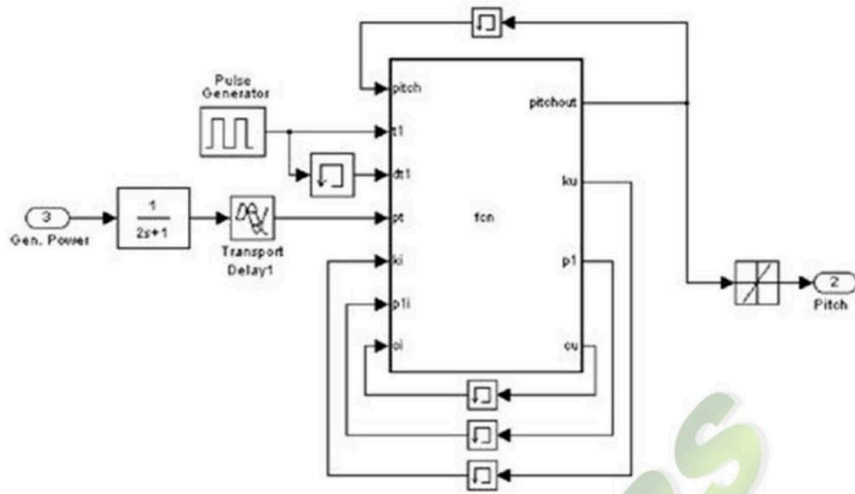

```

1  function [pitchout,ku,plu,cu] =fcn(pitch,t1,dt1,pt,ki,pli,ci)
2  -  ku=ki;
3  -  plu=pli;
4  -  cu=ci;
5  -  pitchout=pitch;
6  -  if t1 > dt1
7  -      pitchout=pitch+1;
8  -      ku=ku+1;
9  -      if pt<pli
10 -          if cu>0
11 -              cu=-1;
12 -          else
13 -              cu=cu-1;
14 -          end
15 -      elseif cu<0
16 -          cu=1;
17 -      elseif cu>0
18 -          cu=cu+1;
19 -      end
20 -      plu=pt;
21  end
22 -  if t1 < dt1
23 -      pitchout=pitch-1;
24 -      ku=ku+1;
25 -      if pt>pli
26 -          if cu>0
27 -              cu=-1;
28 -          else
29 -              cu=cu-1;
30 -          end
31 -      elseif cu<0
32 -          cu=1;
33 -      elseif cu>0 || cu==0
34 -          cu=cu+1;
35 -      end
36 -      plu=pt;
37  end
38 -  if cu > 2
39 -      pitchout=pitchout+1;
40 -      cu=0;
41  end
42
43 -  if cu < -2
44 -      pitchout=pitchout-1;
45 -      cu=0;
46  end
47 -  if pitchout < -6
48 -      pitchout = -6;
49  end

```

Pitch search function for variable rotor speed operation

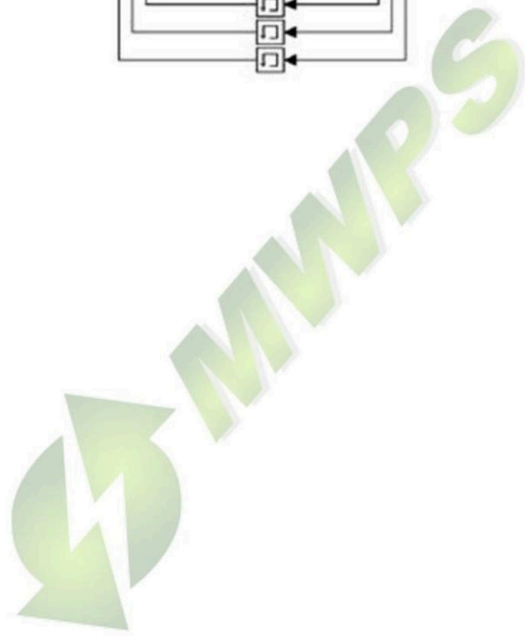
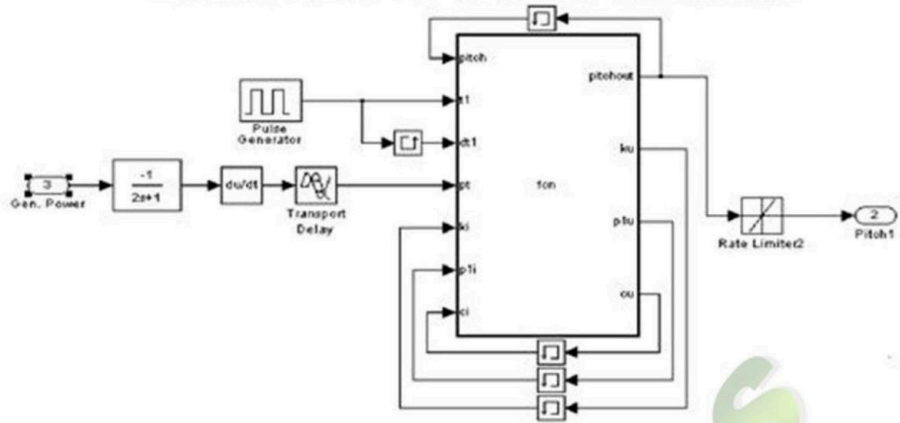

Matlab script, searching function, variable rotor speed operation

```
1 function [pitchout, ku, pliu, cu] =fcn(pitch, t1, dt1, pt, ki, pli, ci)
2 - ku=ki;
3 - pliu=pli;
4 - cu=ci;
5 - pitchout=pitch;
6 - if t1 > dt1
7 -     pitchout=pitch+1;
8 -     ku=ku+1;
9 -     if pt<pli
10 -         if cu>0
11 -             cu=-1;
12 -         else
13 -             cu=cu-1;
14 -         end
15 -     elseif cu<0
16 -         cu=1;
17 -     elseif cu>0
18 -         cu=cu+1;
19 -     end
20 -     pliu=pt;
21 - end
22 - if t1 < dt1
23 -     pitchout=pitch-1;
24 -     ku=ku+1;
25 -     if pt>pli
26 -         if cu>0
27 -             cu=-1;
28 -         else
29 -             cu=cu-1;
30 -         end
31 -     elseif cu<0
32 -         cu=1;
33 -     elseif cu>0 || cu==0
34 -         cu=cu+1;
35 -     end
36 -     pliu=pt;
37 - end
38 - if cu > 3
39 -     pitchout=pitchout+1.5;
40 -     cu=0;
41 - end
42 - if cu < -3
43 -     pitchout=pitchout-1.5;
44 -     cu=0;
45 - end
46 - if pitchout < -6
47 -     pitchout = -6;
48 - end
```

Appendix 5: Effective wind model filters

$$H_F(i\omega) = \frac{K_V}{(1+i\omega T_V)^{5/6}} \quad [\text{Leithead W, et al., 2000}]$$

White noise = W_n

Wind speed turbulence component = v

$$v(s) = \sigma_w \cdot W_n \cdot H_F(s) \quad [\text{Leithead W, et al., 2000}]$$

$$H_{SF}(i\omega) = \frac{\omega_{SF}}{i\omega + \omega_{SF}} \quad [\text{Leithead W, et al., 2000}]$$

$$H_{RSF}(i\omega) = \frac{(NP)^2 + d^2}{(NP)^2} \cdot \frac{(i\omega + NP)^2}{(d^2 + (NP)^2 - \omega^2) + i\omega 2D} \quad [\text{Leithead W, et al., 2000}]$$

$$H_{RSF}(s) = \frac{(NP)^2 + D^2}{(NP)^2} \cdot \frac{(S + NP)^2}{(s^2 + 2Ds + (D^2 + (NP)^2))}$$

Damping factor and cut in frequency [Petru, T. et al., 2002]

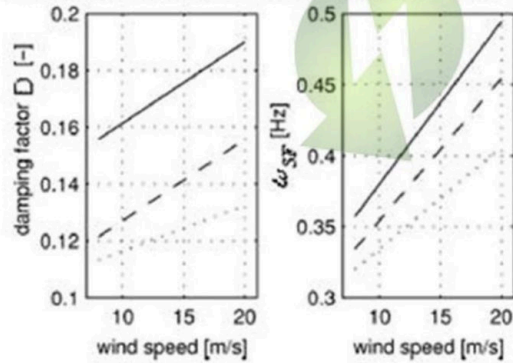

Fitted curve for D and ω_{SF}

$$D \approx 0.12 + 0.0134 \cdot \bar{V}$$

$$\omega_{SF} \approx 0.325 + 0.0034 \cdot \bar{V}$$