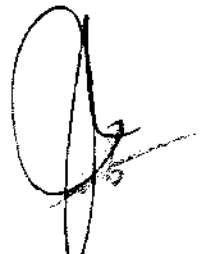


## Contents

	Page
1. INTRODUCTION	3
2. MWT62/1000A EQUIPMENT AND COMPONENT	
2.1 Rotor	4
2.2 Power Train	5
2.3 Yaw System	6
2.4 Tower	6
2.5 Safety and Control System	6
Fig.2-1 Safety System Concept	9
Fig.2-2 Control System Concept	10
Fig.2-3 WIND TURBINE CONTROL SYSTEM	11
Fig.2-4 PITCH CONTROL SYSTEM	12
Fig.2-5 YAW CONTROL SYSTEM	13
Fig.2-6 OVERSPEED PROTECTION SYSTEM	14
Fig.2-7 OVER POWER PROTECTION SYSTEM	15
Fig.2-8 LIGHTNING PROTECTION SYSTEM	16
3. MWT62/1000A SPECIFICATION	
3.1 Specifications	17
3.2 Design	21
3.3 Standard	22
3.4 Documents	22
4. SCOPE of SUPPLY	23
5. POWER CURVE	27
Attachment 1 Outline of MWT62/1000A Wind Turbine	29
Attachment 2 General Arrangement	30
Attachment 3 Division of Responsibilities between MHI and Customer	31
Attachment 4 Lightning Protection for Wind turbine	32



## **1. INTRODUCTION**

MWT62/1000A Wind Turbine Generator is a new generation of wind turbine generator designed with light-weight rotor blades and a 69 meter tower.

The design features of the MWT62/1000A wind turbine are as follows.

- a) Upwind, three blades, Variable pitch control
- b) Active yaw system to track wind direction and Yaw brake to restrain rattling move.
- c) Efficient, lightweight and planetary/parallel/parallel gear box.
- d) Single Speed Type induction generator with Soft starter to restrain rash.

The outline of MWT62/1000A Wind Turbine is shown in **attachment 1** and the general arrangement of MWT62/1000A is shown in **attachment 2**.

Quality Control: MWT62/1000A is manufactured in accordance with ISO-9001 (2000 edition)

This sheet shows the engineering specification for one MWT62/1000A turbine

**Designed Basic Condition:**

**MWT62/1000A Wind Turbine Generator is designed in accordance with IEC Class IIA, Seismic Zone 1 and 2 in accordance with UBC 1997**



## **2. EQUIPMENT AND COMPONENT**

MWT62/1000A is mainly composed of the following Components.

- Rotor, Blades, Pitch system
- Power train (Main Shaft, Gearbox, Generator and Brake)
- Yaw system (Yaw gear and Yaw driven device)
- Nacelle bed-plate
- Tower
- Controller and Terminal for Communication System

### **2.1 Rotor**

The rotor has three blades and each blade can rotate along its longitudinal axis by the pitch control mechanism in the rotor head to capture wind energy, to regulate power and serve them as an aerodynamic brake. The Rotor connects the three blades to the power train via the main shaft, the gearbox and so on, in order to transmit such wind power given on the blades.

#### **2.1.1 Blades**

The rotor has three GFRP (Glass Fiber Reinforced Plastic) blades. Each blade is approximately 29.5 meters long and employs the modified NACA 63-XXX series airfoil.

The blade has approximately 20 degrees twist from the root to the tip. The maximum chord length is about 2,300 mm and tapers down to about 100 mm near the tip. The blades are mounted to the rotor head at a cone angle of 0 degree.

In general, a turbine blade should exhibit two contradictory characteristics: one is to obtain maximum power under low wind speeds and another is to regulate power under high wind speed. To address this contradiction, the MWT-series is designed as a "Blade pitch control type WTG" instead of "Stall control". There is no requirement to fit any parts in the blade, which the stall control type WTGs usually require.

The Blade structure consists of two skins (High Pressure skin and Low Pressure skin) and two shear webs (Leading Edge side shear web and Trailing Edge side shear web). These parts are made of GFRP (Glass Fiber Reinforced Plastics) and core material (Wood or Plastic Foam material) without any Carbon Fiber and metal mesh material. These are bonded by adhesive. Blades are installed on the rotor head and connected by T-bolt connections.

For lightning protection, metal tip receptor is installed at the blade tip. A down conductor is wired in the blade from a tip receptor to the metal part of the rotor head in order to lead lightning current to the ground.

#### **2.1.2 Rotor Head**

The Rotor connects the three blades to the power train via the main shaft, the gearbox and so on.

The given blade loads (static, dynamic wind loads and centrifugal forces) are transmitted to the nacelle bed-plate through the low speed shaft and bearings.

The linkage-mechanism, power cylinder and other linkage parts, for the blade pitch control is installed in the rotor head.

### 2.1.3 Pitch Control Mechanism

Pitch control is used to control the power generation and prevent the WTG from getting into over-speed, over-power or so on and to stop the rotor.

The pitch control mechanism consists of the hydraulic pump unit, cylinders, servo control valves, feedback sensors, linear accumulator, linkages and the like.

The hydraulic pump unit including the servo valve, other valves and the accumulator are mounted in the nacelle and run the hydraulic oil into the power cylinder through the hydraulic piping.

In the event the hydraulic pump does not work, the accumulated pressure in the accumulator can make the power cylinder activate to move the blade pitch. Hence, even if the power supply for the turbine turns off, the blade pitch can be closed to the feathering position and the rotor speed can be reduced nearly zero rpm.

## 2.2 Power Train

The power train axis is inclined around 5 degrees (tilt angle) from the horizontal (tilting).

A low speed (19.8 rpm) shaft, or main shaft, connects the rotor head to the driving shaft of a 1:92.065 for 60Hz gearbox. The gearbox transmits the power from a main shaft to the generator.

The driven high speed shaft of the gearbox connects to the generator through a flexible coupling. A rotor brake is equipped on the high speed shaft and used primarily to secure the rotor from rotation during maintenance work. In addition, on both sides of high-speed and low-speed shaft, a locking device for the rotor rotation is installed for the use during maintenance and/or the special work.

### 2.2.1 Gearbox

The gearbox is composed of 3 stage gears, planetary, parallel and parallel gear, in order to increase the hub rotational speed of 19.8rpm to the generator driving speed of 1822rpm for 60Hz.

A Lubricating oil pump is equipped near the gearbox to force oil flow through those gears and bearings for lubricating and cooling the gearbox. The gearbox is mounted on the nacelle bed-plate through a frame, called the torque arm and anti-vibration bushing, to contribute to reduction of mechanical noise from the gearbox. All gears are manufactured from carbonized steel.

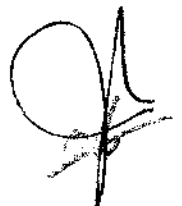
### 2.2.2 Generator

The generator is an AC induction generator of 600V, 4poles, 60Hz, rated at 1000kW with a power factor of more than 0.98 from 25% load to 100% load at 600V, 60Hz.

In accordance of generator specification, Substation Power Factor Facilities shall be designed by Buyer in order to meet the grid requirements.

### 2.2.3 Braking system

There are two types of brakes. One type is an aerodynamic brake effected by the blades and the other type is a disk brake equipped on the high speed shaft. Those brakes are as described in "Safety and Control Systems Concepts" and Section 2.2 above.



### 2.3 Yaw System

In order to follow the shifting wind direction, the nacelle can rotated automatically to the prevailing wind direction. The Yaw system consists of a yawing device (yaw motor and yaw drive), yaw brake and yaw bearing. The yawing device provides yawing force through the gear of the yaw bearing. The yaw brake can clamp the brake disc to maintain the nacelle direction against the wind load.

### 2.4 Tower

A tapered mono-pole tower supports the nacelle. Two tower heights are available of approximately about 69 m for installation upon the owner's reinforced concrete foundation. The tower, when properly secured to the foundation is designed to withstand 60 m/s of the instantaneous wind speed at the hub height under the blade feathering condition.

### 2.5 Safety and Control System

#### Safety and Control System Concept

The Safety and Control System concept is based on a software driven Control System with a Safety System consisting of discrete hardware sensors connected in parallel to two Safety Relays.

The concept is shown in **Fig 2-1 Safety System Concept** and **Fig.2-2 Control System Concept**.

The Safety System Concept is mainly effected through three stepped critical failure responses decided by the intensity of how a fault or alarm may influence each component of the turbine.

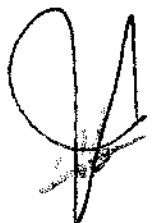
- Critical Failure 1 includes generator over power, short circuit and the like which shall actuate only the aerodynamic brake.
- Critical Failure 2 includes the low speed shaft over-speed, the high speed shaft over-speed and the like which shall actuate the aerodynamic brake and the mechanical disk brake at the same time.
- Critical Failure 3 includes the control failure, the emergency stop and the like which shall actuate the aerodynamic brake and the mechanical disk brake with a time lag between them.

The Control System for turbine determines a fault or alarm from sensor or relay signals identifies a failure from each detected signal and makes the turbine shutdown pursuant to the Safety System Concept.

The Control System and Safety System have a common power supply from the low voltage transformer. Each Turbine has a common battery backup system (UPS, Un-interruptible Power Supply) to supply the Control System, the Safety Relays and Hydraulic system for ten minutes after a grid loss. After exhausting UPS, the CPU (Central Processing Unit), has another internal battery for its power supply, and can retain all programs, fault and alarm information.

The wind turbine generator safety and control system can perform the following functions. (Refer to **Fig.2-3 the Wind Turbine Control System**)

- Blade Pitch control
- Yaw control.
- Safety System and/or
- Manual Control by Handy Terminal
- Remote Control
- Etc.



### 2.5.1 Blade Pitch Control

The power output of the turbine is regulated by the blade pitch control system, using the wind speed from the anemometer on the nacelle and the output of the generator.

When the wind speed is below "cut-in" wind speed or over "cut-out" wind speed, the blades are feathered to prevent the rotor from excessive rotation.

At wind speeds between "rated" and "cut-out" wind speed, the blade pitch can be controlled to maintain constant power output (rated power).

(Refer to Fig.2-4 Pitch Control System)

### 2.5.2 Yaw Control

The yaw control system can control the wind turbine to keep its position against the wind direction. If yawing is not available, the wind turbine can shut down by the control system with proper alarm or fault detection. (Refer to Fig.2-5 the Yaw Control System).

The MWT62/1000A includes a "Smart Yaw System" to control the nacelle direction to reverse against the wind direction and to reduce estimated loads to the wind turbine. This system allows the turbine to be controlled by the down wind mode during the extreme wind conditions.

### 2.5.3 Safety System

The Safety and Control System enables automatic shut-down, operates independently of all other wind turbines and monitors through various sensors, such as the rotor speed, generator output and current, nacelle vibration, emergency switches, functioning signal of control system, electrical load, yaw error, governing hydraulic pressure, lubricant oil pressure and its temperature, and other operating conditions and circumstances. When signals from the sensors exceed each designed parameter, the control system would command to automatically stop turbine operation.

### 2.5.4 Power and Control Panel

The Power and Control Panel is located at the base of the tower of each wind turbine contains the universal controller with CPU which is the hub for control system. An operator can manually operate the turbine from this panel in accordance with procedures defined in the Operating Manual.

### 2.5.5 Handy Terminal

The "Handy Terminal" is a portable instrument to access directly the Power and Control Panel at the local turbine position. It provides an interface control panel to controller and the following data can be read on the displays of handy terminal.

- 1) Error Indicator
- 2) Accumulated power output in kWh
- 3) Power output in kW (average & instant)
- 4) Internal power in kW
- 5) Wind speed (average & instant) in m/s
- 6) Accumulated generator on-off times
- 7) Accumulated WTG running hours
- 8) Accumulated yaw right and left turn cycles
- 9) Current nacelle direction
- 10) Yaw error (wind difference angle)
- 11) Pitch angle (command & actual)
- 12) Current rotational speed(High and Low speed shaft)



- 13) Temperature for inside gearbox, lubricant oil, gear bearings, generator winding, generator bearing, ambient and inside nacelle in Celsius
- 14) Lubricant oil pressure in MPa
- 15) Each electric relay and command signal

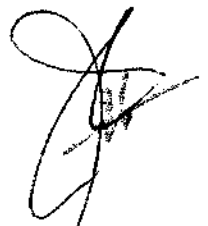
#### 2.5.6 Remote control

Each MWT62/1000A wind turbines can be operated independently and each safety control system can be an interface for operators in a remote station. The MWT62/1000A wind turbine controller has Ethernet I/P to link to the customer's communication line.

#### 2.5.7 Lightning Protection

The MWT62/1000A wind turbine has a lightning rod at top of a nacelle. Anemometer, wind vane, other sensitive parts in the nacelle and the control systems including the control board are protected from noise or surge spike due to lightning or lightning storm by an upgraded shield system protection, which has the surge arrester, the lightning arrester, the varistor and the ferrite core. These shields were mounted into both of the nacelle and generator control panel. Refer to the followings for the protection and Fig.2-8.

- 1) Power Line  
Surge arresters are mounted for 600[V] power line, 5 and 24[V] for control circuit, switches 100[V] for electric magnetic valve.
- 2) Controller  
Surge arrester, ferrite core, and capacitor are mounted for controller.
- 3) Anemometer, Wind Vane and RTD(Resistance Thermometer Sensors)  
Surge arresters are necessary for the detector such as anemometer, wind vane and RTD in and on nacelle.
- 4) Potentiometer(Wind Vane and Yaw)  
Varistors are set for each sensor in order to hold high surge voltage.
- 5) Each rotor blade has a tip receptor to receive lightning current. The lightning current is led from blade tip receptor to the ground through a down conductor in blade and lightning brushes for bearing by-pass. The blade lightning protection system is designed according to "IEC TR 61400-24 1st ed. Wind Turbine Generator System Part 24: Lightning protection" and protection level "IEC I".
- 6) Lightning rod is installed on the top of nacelle to lead lightning current to the ground.



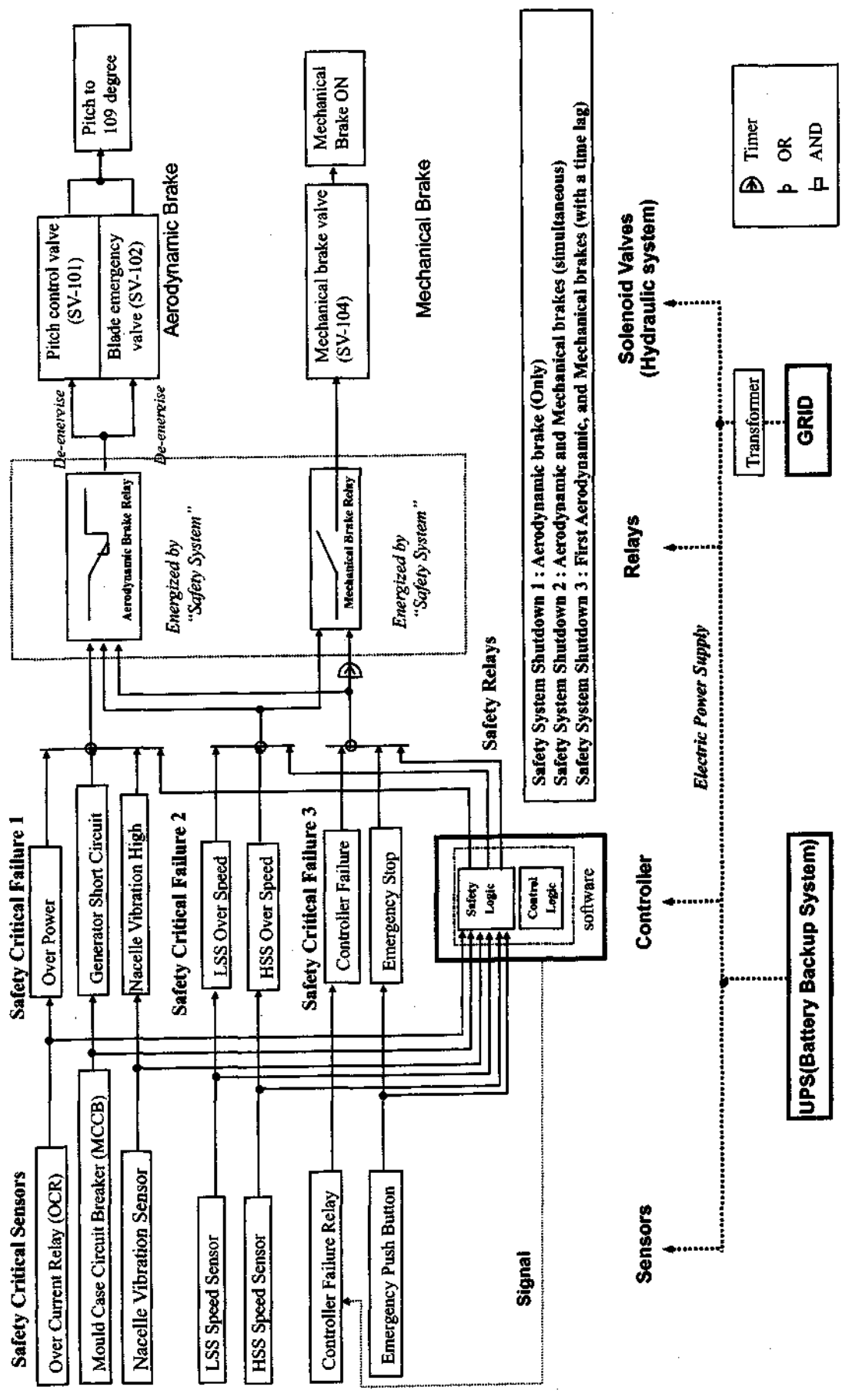


Fig. 2-1 Safety System Concept



Minor Defects : Minor faults that don't cause serious damage to the turbine

- Over or Under frequency †
- Under voltage †
- Blade pitch angle signal fault\*
- Blade pitch direction signal fault\*
- Nacelle direction signal fault\*
- Generator output deflection fault\*
- Wind direction deflection fault\*
- DC control voltage low\*
- Power converter fault\*
- Generator voltage signal fault\*
- Generator hard limit
- Yawing time-out
- Yaw motor overload
- Yaw motor slow or high speed running\*
- Yaw motor slow or high speed running\*
- GO, oil pressure low\*
- GO, pump motor stop\*
- GO, level low\*
- L.O. pressure low\*
- Yaw brake pressure low
- Yaw brake pressure un-demanded application
- Mechanical brake control delayed
- Soft starter abnormal
- Soft starter self-induced
- Generator temperature high\*
- Generator temperature high\*
- Reactor temperature high\*
- High speed shaft speed sensor fault\*
- Low speed shaft speed sensor fault\*
- Start failure\*
- Pitch transducer fault\*
- Pitch transducer\*
- DPS abnormal\*
- Speed sensor difference large\*
- Speed sensor speed error large\*
- Calculated wind speed error large\*
- Accumulator charge insufficient

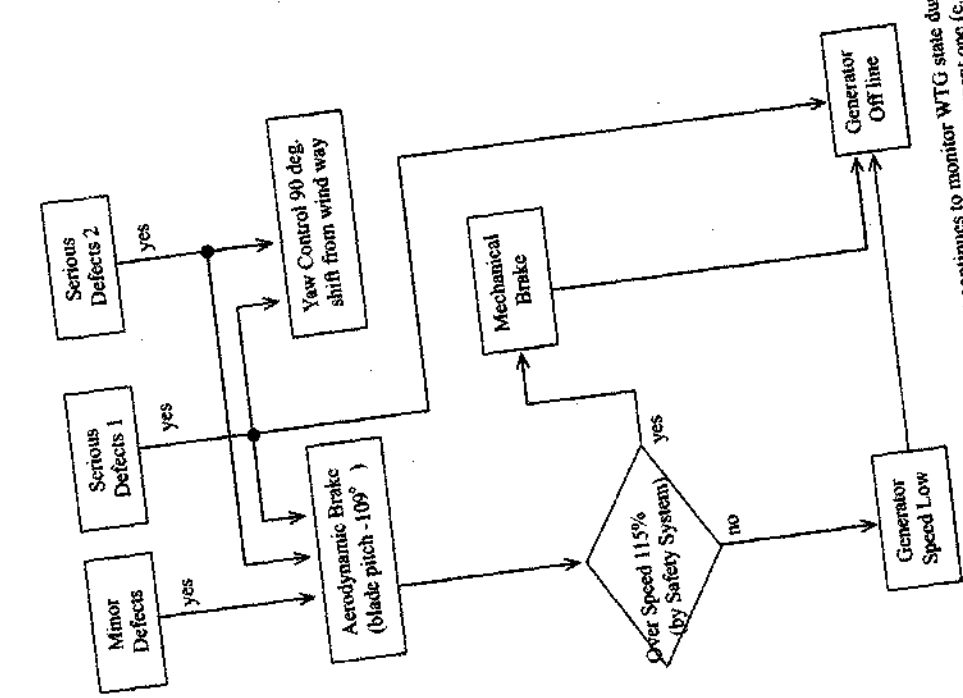
Serious Defect 1 : Electrical faults that need immediate separation of Generator

- Over current of single phase of Generator
- Over voltage
- External power loss †
- Earth Leakage
- MCCB-1 Trip

Serious Defect 2 : Faults that initiate yawing to deduce acceleration of blade

- Blade pitch control error large
- Blade pitch control fault
- Blade pitch slow running
- Blade pitch stop running †
- Over power [Software] †
- Software over-speed
- Mechanical brake pads worn or pressure lost
- Actual pitch error large

\*: Remotely reset fault, †: Automatically reset by Control System

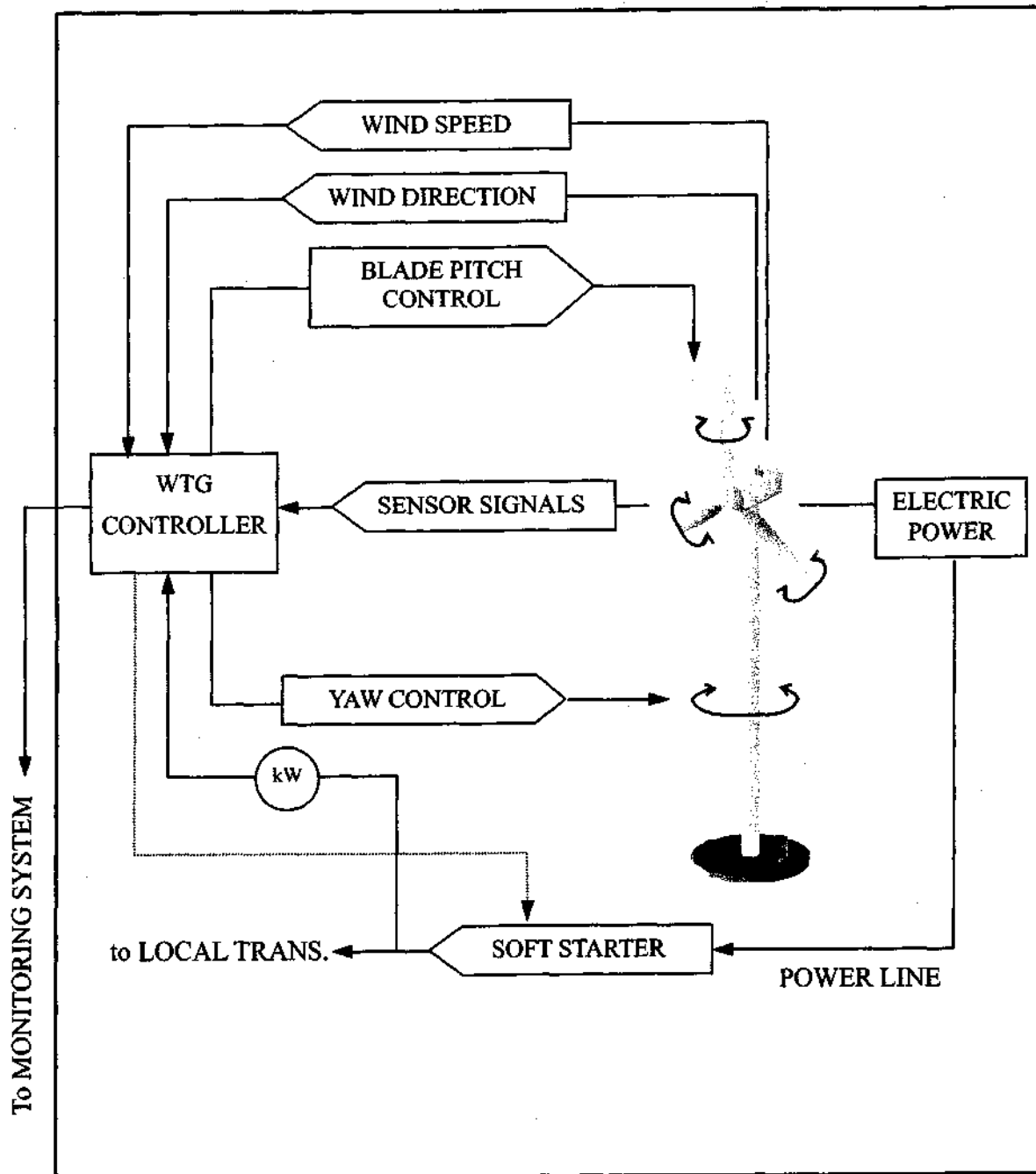


The Safety System and Control System continues to monitor WTG state during  
 The stop type can be changed from the current one to a more urgent one (e.g. Over Speed).  
 Serious Defect 1: Electrical faults that need immediate separation of Generator.  
 Serious Defect 2: Faults that initiate yawing to reduce acceleration of blade.

Fig. 2-2 Control System Concept



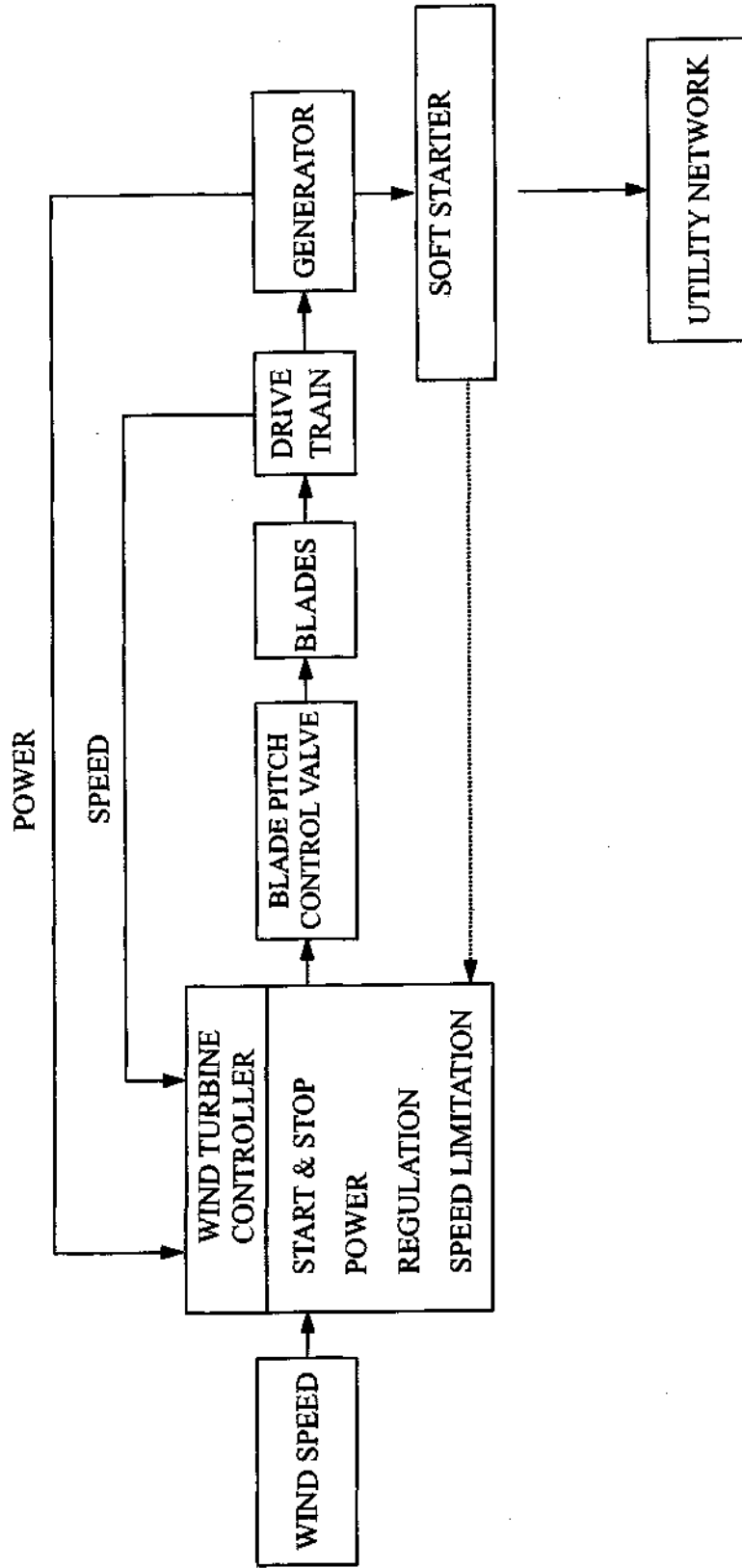
**Fig. 2-3 WIND TURBINE CONTROL SYSTEM**



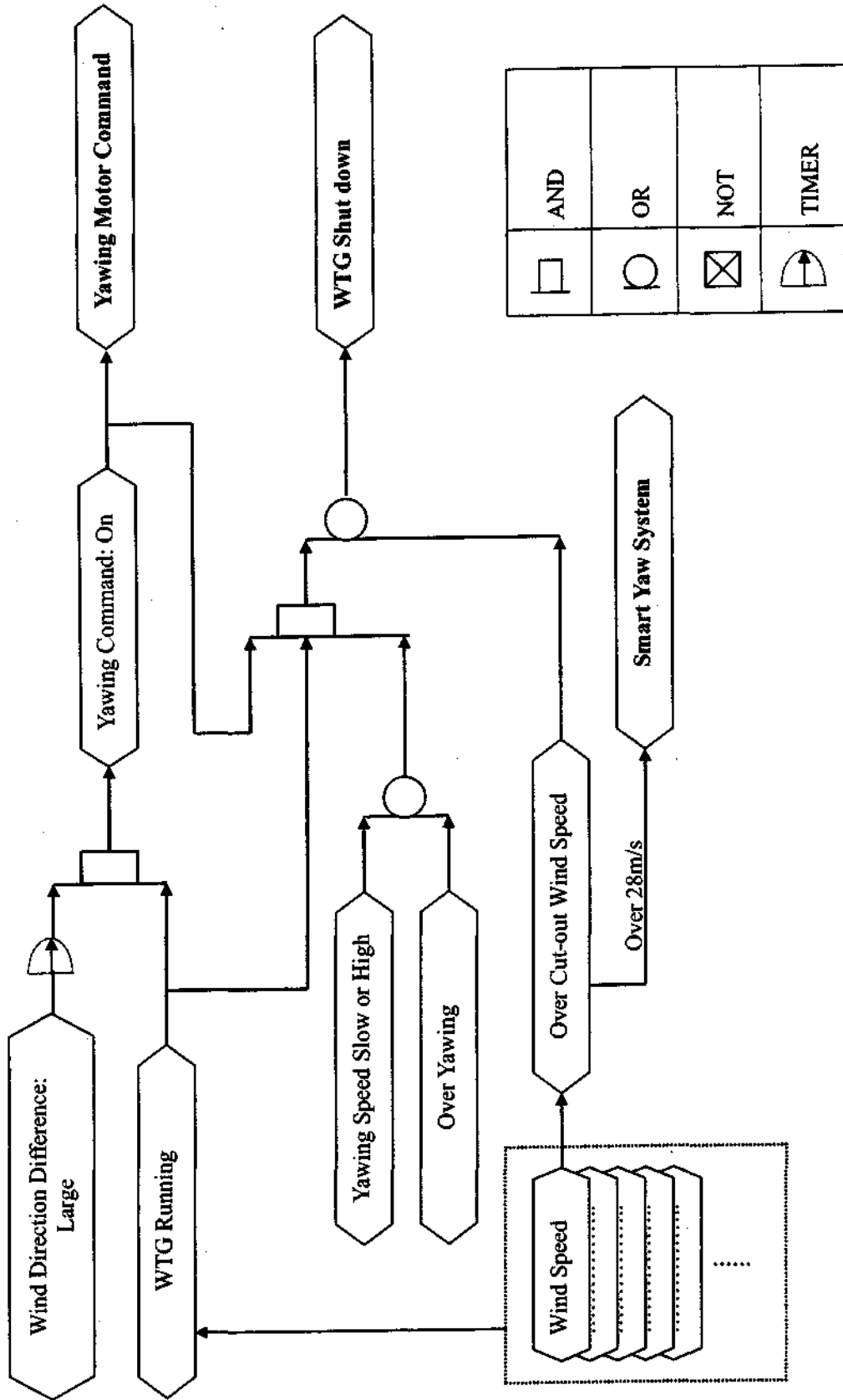
\* Soft starter is installed in power and control panel.



**Fig. 2-4 PITCH CONTROL SYSTEM**

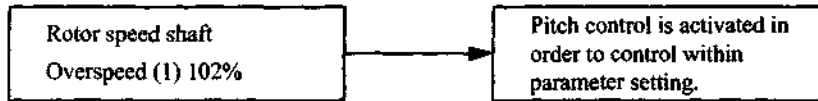


**Fig. 2-5 YAW CONTROL SYSTEM**

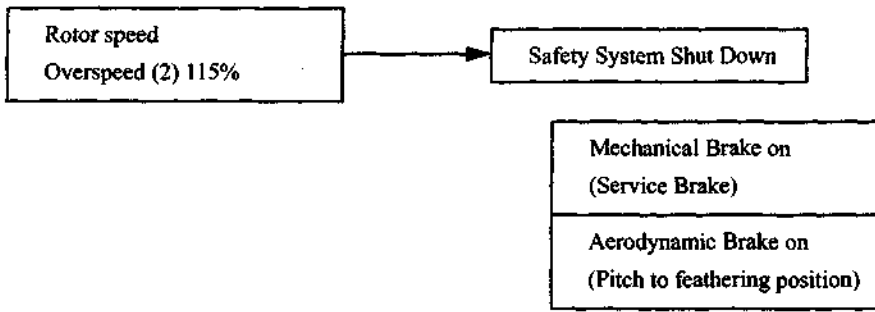


## Fig. 2-6 OVERSPEED PROTECTION SYSTEM

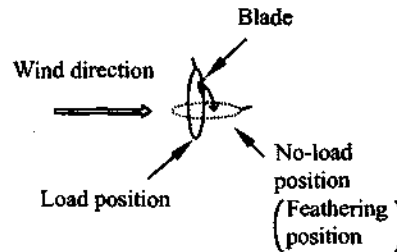
### 1ST STEP



### 2ND STEP



Blade pitch is changed from load position to no-load position

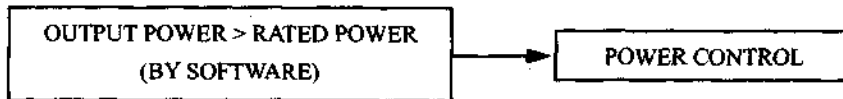


< REMARK >

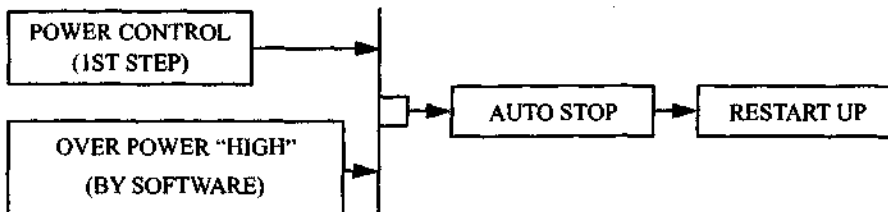
□	AND
○	OR

## Fig.2-7 OVER POWER PROTECTION SYSTEM

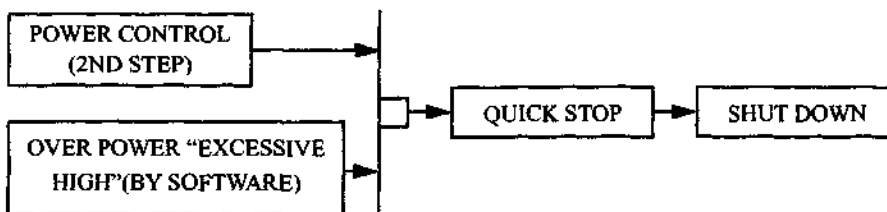
### 1ST STEP



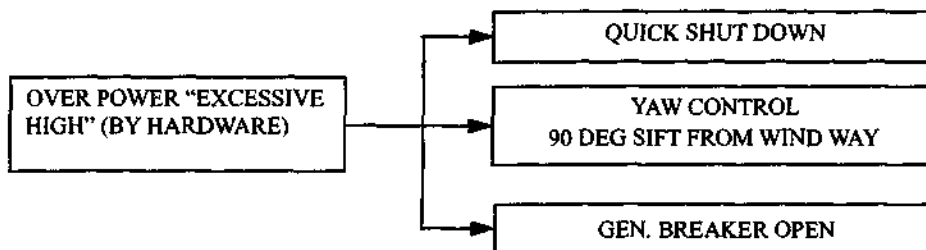
### 2ND STEP



### 3RD STEP



### 4TH STEP



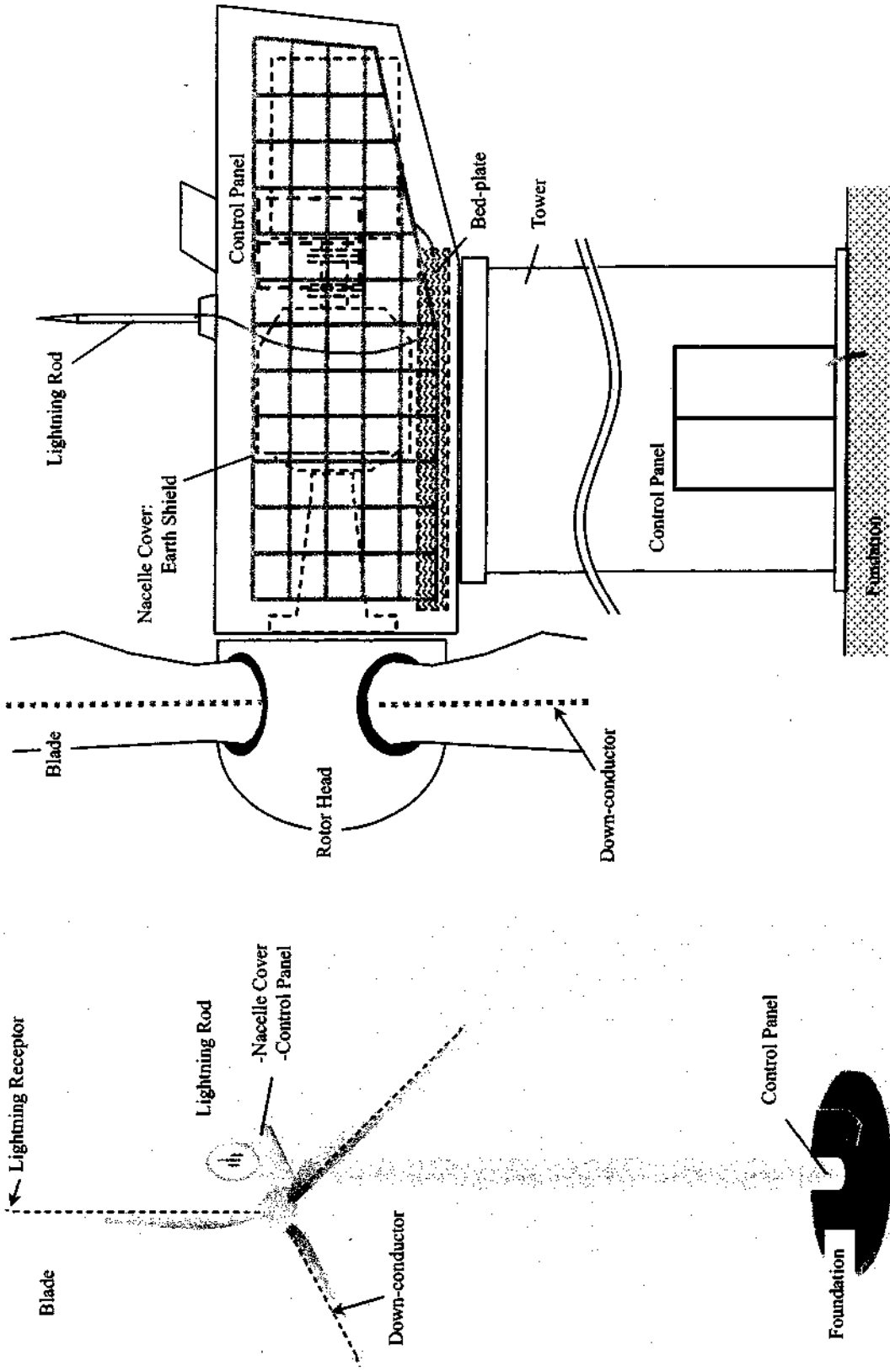
#### Remarks:

"Auto Stop" means normal stop for WTG as blade moving from operation to feathering position slowly.

"Quick Stop" means emergency stop for WTG as blade moving from operation to feathering position quickly and yawing to 90degree of the wind direction.

"Quick Shut-down" means emergency stop with the main breaker tripped.

**Fig.2-8 LIGHTNING PROTECTION SYSTEM**



### **3. MWT62/1000A SPECIFICATION**

Primary Specification and standard of "MWT62/1000A" is as follows.

#### **3.1 General Specifications**

Rating output	1000 kW
Rotor diameter	61.4 m
Hub height	69 m
Swept area	2960 m <sup>2</sup>
Rotational speed	19.8 rpm
Rotor Regulation	Full span pitch control
Yaw orientation	Active Yaw control
Designed Wind Class	IEC Class IIA

#### **3.1.1 Performance**

Rating output	1000 kW
Power curve*	Refer to Section 5 of this specification
* Air Density 1.225 kg/m <sup>3</sup> at 10 minutes average, as assumed	
Operation parameters at Hub height	
Rated wind speed	12.5 m/s
Cut-in	3.0 m/s at 10 minutes (*1)
Cut-out	25.0 m/s at 10 minutes (30.0m/s during 2sec.)
Reset from Cut-out	20.0 m/s
Design against the gust (*2)	60 m/s (Instantaneous)
*1: It might be modified in accordance with site wind load condition to meet IEC Class IIA.	
*2: It is under the condition that blade keep feathering against the wind.	

#### **3.1.2 Rotor**

Number of Blades	3
Diameter	61.4 m
Swept area	2,960 m <sup>2</sup>
Hub Height	69 m
Revolution Speed	19.8 rpm
Tip Speed	63.7 m/s
Rotational Direction	Clockwise against wind direction
Orientation	Upwind
Cone Angle	0 degrees (Vertical to rotor axis)
Tilt Angle	approx. +5 degrees to horizontal line
Power regulation	Blade pitch control

#### **3.1.3 Blade**

Length	Nominal 29.5 m
Material	GFRP
The conductible material is only fitting bolt at the root.	
Airfoil (profile)	NACA 63-XXX
Twist from root to tip	approximately 20 degrees
Chord Length	Root
Tip	approximately 2,300 mm
	Tip
	approximately 100 mm



Type of rotor aerodynamic brake	Full span pitch control
Weight per a blade	approximately 4,600 kg
<b>3.1.4 Hub</b>	
Type	Cast
Material	JIS FCD400-18L
Corrosion	Anti-Corrosion Painted
<b>3.1.5 Nacelle bed</b>	
Type	Welded steel structure type
Material	JIS SS400
Corrosion	Anti-Corrosion Painted
<b>3.1.6 Main shaft</b>	
Type	Forged steel type
Material	JIS S45C
<b>3.1.7 Main bearing</b>	
Type	Spherical roller bearing type
No. of bearing	1 piece
<b>3.1.8 Gearbox</b>	
Type	3 stages Planetary/Helical/Helical
Gear Ratio	approximately 1:92.065 for 60Hz
Nominal rating	1000 kW
Rotational Speed	
High Speed Shaft to generator	abt. 1822 rpm
Low Speed Shaft to rotor	19.8 rpm
Oil Lubrication	Oil bath, Splash and forced feed lubrication
<b>3.1.9 Lubricant Oil System</b>	
Oil type	ISO-VG320
Working pressure	0.50 MPa
Pump capacity (for Cooling)	90l/min, 5.5kWx 600Vx 60Hz
Pump capacity (for Purify)	0.37kWx 600Vx 60Hz
Gear oil maximum temperature	60 degree C at oil inlet side
Oil filtering size (for Cooling)	20 micron ( $\beta_{20} \geq 200$ )
Oil filtering size (for Purifier)	5 micron ( $\beta_5 \geq 1000$ )
Oil Cooler	Dual oil coolers with fan cooled system
Cooling Capacity	26 kW in each
<b>3.1.10 Coupling</b>	
Type	Flexible type flange shaft coupling

### 3.1.11 Generator

Type	Asynchronous AC induction Generator
Nominal Capacity	1000 kW
Number of Poles	4 poles
Synchronous Speed	1800 rpm
Potential voltage	600 V
Frequency	60 Hz
Enclosure & Protection	Totally-Enclosed Fan Cooling
Rotor Type	Squirrel-Cage Windings
Insulation	F
Rating	Continuous

### 3.1.12 Nacelle

Nacelle Utilities	Emergency stop button, Service socket, Service valve of hydraulic, Lights, Lifting winch, Hatch to the outside, Blade inspection cripple, Maintenance area of rotor head
-------------------	---

### 3.1.13 Yaw System

Control type	Active feedback
Wind Direction Difference*	without +/-15 deg. for 15 sec below 6 m/s without +/-20 deg. for 20 sec over 6 m/s
Yaw Drive	Geared Induction Motor
Rating Power	2.2 kW x 2sets
Orientation speed of nacelle	abt.0.4 degrees/sec
Support	4 points bearing
*When wind direction difference becomes above 15deg or below -15deg, such direction difference would be begun to control to 0deg.	

### 3.1.14 Hydraulic unit

Function	Governing oil unit (Control for blade pitch, main shaft brake and yaw brake)
Working pressure	9.0 MPa (Dead Head 10.5MPa)
Oil type	ISO VG32
Pump capacity	54 l/min, 11kWx 600Vx 60Hz
Oil cooler	Coupling cooler
Cooling capacity	2.5kW

### 3.1.15 Mechanical service brake

Type	Disk brake
Material	Steel, mounted on high speed shaft
Number of caliper	2 pieces

### 3.1.16 Mechanical yaw brake

Type	Disk brake
Material	Steel
Number of caliper	4 pieces

### 3.1.17 Wind Turbine control system

Power Regulation	Full span Pitch control
Yaw Orientation	Active YAW control
Cut in	Soft starter (Thyristor)
Control method	Manual at the site, Remote start and/or stop by the distance control
Communication method	Ethernet
Methodology	Anemometer, Wind vanes

### 3.1.18 Safety System

Brake system	Pitch control Disc brake and lock pin on the high speed shaft, Lock pin on the low speed shaft
Safety System Shutdown	Over speed Generator over power (over current) Generator Short Circuit Excessive Vibration Emergency Button Shutdown Functional of control system
Control System Shutdown	Hydraulic System Abnormal Lubricant abnormal Generator abnormal Sensor signal abnormal etc.

### 3.1.19 Tower

Type	Tapered Mono-pole
Materials	Steel
Hub Height	69 m
Ground Clearance	approximately 38.3 m (Hub Height 69 m)
Top Diameter	approximately 2.5 m
Base Diameter	approximately 4.0 m (69 m)
Tower utilities	A ladder, Stage floors, Safety wire, Lights, Door, Pad lock, Base floor for control panel
Number of sections	3 sections (69 m)

### 3.1.20 Painting and surface finish

Standard color	Light gray (Munsel code N-8.5)
Nacelle outside	4 <sup>th</sup> (Primer, Epoxy, Polyurethane, Polyurethane)
Blade	Gel-coat coating
Tower outside	3 <sup>rd</sup> (Primer, Epoxy, Acrylic)

### 3.1.21 Lightning protection

Nacelle	Conductor rod, earth shield on nacelle cover to lead out into the frame of itself
Blade	There is a metal tip receptor at blade tip and Down-conductor wired in blade To lead out into the frame of itself
Tower	Mitsubishi grounding system
Foundation	Shield protection
Control unit	



### 3.1.22 Weight (Approximate)

Total weight of the nacelle (Include in Nacelle, Rotor, Blades)	Approximately* 75,000kg
Tower	Approximately* 94,000kg (69m)
* Weight has +/-5% allowance	

### 3.1.23 Environment Condition

Temperature	IEC Class II standard condition
Elevation*	under 1000 meters or lower above sea level
*When the site elevation shall be over this condition, it shall be evaluated as special optional condition latter.	
Seismic Condition	Seismic Zone 1 and 2 in accordance with UBC 1997

### 3.1.24 Operating Grid Requirements

Grid Voltage	600V +/-10%
Grid Frequency	60Hz +/-1Hz

### 3.1.25 Earthing System Requirements

Ground resistance  
Below 2 ohm: Isolated from project grid condition  
In case of over 2 ohm, the following ground resistance shall be required.  
Below 5 ohm: Isolated from project grid condition  
Below 2 ohm: Connected to project grid condition

### 3.1.26 Limitation of WTG Operation

Depended on Site Wind condition & Layout, some curtailment might be imposed in order to reduce the fatigue load to meet IEC class IIA wind load. After MHI will receive and evaluate the customer's site wind measured data, necessary curtailment shall be informed to Customer.

## 3.2 Design

The Main parts as identified below have been designed for the required life by Germanischer Lloyd standards, under the certified design load.

FRP blade  
Rotor Head Structure  
Nacelle bed-plate  
Main shaft  
Main Gearbox\*  
Generator\*  
Yaw Gear\*  
Pedestal for main shaft bearing  
Tower Structure\*

\*Except for Seals and Consumable parts

### **3.3 Standards**

#### **3.3.1 Technical Standards**

MWT62/1000A wind turbine generator and its electrical equipment are manufactured in accordance with IEC (International Electro-technical Commission) and the following Japanese standards, in effect as of June in 2004.

- IEC (International Electro technical Commission)
- JIS (Japanese Industrial Standard)
- JEM (The Standard of Japan Electrical Manufacturer Association)
- JEC (Japanese Electro-technical Committee)

#### **3.3.2 Quality Control**

MWT62/1000A is manufactured at the facility in accordance with ISO-9001(2000 edition).

### **3.4 Documents**

Operation and maintenance manual  
Inspection record



**4. SCOPE OF SUPPLY**

The following items are the scope of supply of MWT62/1000A.

The scope of supply shows the **attachment 3**.


The mark in the following table shows MHI : Mitsubishi Heavy Industries, Ltd. and C: Customer

Remark: following Table has described the case of 1.5MW.

No.	Item	Q'ty	Design	Material Supply	Working Supply (Erection)	Remarks
1	Wind Turbine					
1.1	Wind Turbine Generator above Tower (Nacelle) (fully assembled) 1 set / a wind turbine Including: - a nacelle - blades (3) - a rotor - pitch control mechanism - a main gearbox - a rotor brake - a generator - oil unit - a yaw drive - yaw brakes - an anemometer, a wind vane, lightening rod on nacelle - lifting hooks in nacelle	15	MHI	MHI	C	Nacelle and hub will be shipped separately from factory Blades will be shipped with nacelle assembly in order The bolts and nuts, which are provided by Wind turbine, shall be provided by MHI
1.2	Power & Control Panel 1 set / a wind turbine including Soft Starter	15	MHI	MHI	C	
1.3	Electrical Cable from Nacelle to Power & Control Panel 1 set / wind turbine	15	MHI	MHI	C	Lower: Spindle with control panel Top: Installed in nacelle
1.4	Handy Terminal 1 set / 10 units wind turbine	1	MHI	MHI	-	
1.5	Tower 1 set / wind turbine Including: - ladder inside the tower - earth pads - all hardware - Light in Tower	15	MHI	MHI	C	The bolts and nuts, which consist the tower shall be provided by MHI.

No.	Item	Q'ty	Design	Material Supply	Working Supply (Erection)	Remarks
2.	Foundation of Tower -Anchor bolt, nut and washer -Anchor flange -Template -Earth cable from tower to foundation	-	C	C	C	-MHI will inform to customer about control panel size. -MHI supplies the design loading data for foundation.
3.	Central Monitoring System - Software of system - Computer - Communication cable - Etc.	-	C	C	C	
4.	Communication Interface for Central Monitoring System at each Power and Control Panel	-	MHI/C	C	C	10 Base-T receptacle at each power and control panel with MHI standard protocol. (Complied with UDP/IP protocol).
5.	Fire extinguishers	-	C	C	C	Customer investigates necessity of Fire extinguishers and informs MHI.
6.	Air Navigation Warning Light	-	C	C	C	Customer has to investigate Necessity of FFA light and inform MHI.
7.	Land readjustment works - Road repairs to the erection site - Land readjustment at erection site	-	C	C	C	
8.	The provision of paved access to the wind turbine	-	C	C	C	
9.	Grounding from tower bottom to foundation	-	C	C	C	
10.	Installation of wind turbine generator - Installation of the power & control panel - Erection of the tower with ladder - Installation of the nacelle to the top of the tower - Erection of the anemometer and wind vane sensor on nacelle - Connection of the control cables between nacelle and control panel in the tower ground. - Connection of power cables between nacelle and control panel in the tower ground. - Installation of the blades to the rotor head - Installation of the safety cables to the tower ladder Control rooms on site	-	MHI/C	MHI/C	C	MHI provides Installation & Erection Procedure as reference drawing and one (1) set of the specified erection tool for 15MW unit as shown in the "Erection Tool List" Customer provides the general tools.
11.	Control rooms on site	-	C	C	C	

No.	Item	Q'ty	Design	Material Supply	Working Supply (Erection)	Remarks
12	Substation	-	C	C	C	Satisfied capacity with considering the induction generating.
13	Step-up Transformer between WTG and substation	-	C	C	C	Equipped with a breaker.
14	The laying and Connection of Power cable - from the grid of the utility to substation - from substation to transformer - from transformer to Power & control panel of WTG	-	C	C	C	MHI will provide spacing inside the controller for CMS interface Hardware and low voltage supply as long as the information to us before manufacturing WTG.
15	The laying and Connection of Communication Cable - from Power & control panel of WTG to mother computer in substation - from mother computer to telephone line if necessary	-	C	C	C	
16	Transportation					
16.1	Ocean Transportation (Japan - nearest International port of site)	1	MHI	MHI	MHI	
16.2	Inland Transportation (Port - Site)	1	MHI	MHI	MHI	
16.3	Site Unloading	-	C	C	C	
17	Technical Advisor for Installation work of wind turbine, tower, and control panel.	-	MHI	-	C	The fee of this T/A shall be separately quoted.
18	The supervisors for installation work of wind turbine, tower and control panel application for construction permits or the amendment of an existing permits, respectively	-	C	C	C	
19	Commissioning work	-	MHI	C	C	MHI will complete the commissioning work in accordance with the contract. Customer shall supply the qualified worker and tools for the commissioning work. MHI will provide Operation & Maintenance Manual.
20	Technical Adviser for Maintenance & Operation Training on site (if necessary)	-	MHI	-	-	
21	An expertise regarding the ground for the foundations	-	C	C	C	
22	Adjustment work of transformer after power supply	-	C	C	C	

  
 WW EA-A Specification for WT 060210.doc



No.	Item	Q'ty	Design	Material Supply	Working Supply (Erection)	Remarks
23	<ul style="list-style-type: none"> <li>Tests if required</li> <li>- Site Calibration Test</li> <li>- Performance Test</li> <li>- Noise measurement Test</li> <li>- Instrument and measuring system of the Tests</li> </ul>	-	C	C	C	MHI will check the procedure, analysis and data etc. of the tests and MHI can attend the Tests.
24	<ul style="list-style-type: none"> <li>Special Erection tools for WTG</li> <li>- Tower lifting tool</li> <li>- Guide bars</li> <li>- Blade edge protector</li> <li>- Nacelle lifting device (Unload &amp; installation)</li> <li>- Rust preventive paint for blade bolt</li> <li>- Touch up paint</li> </ul>	1	MHI	MHI	-	One (1) set of the special tool will be supplied for 15MW unit.
25	<ul style="list-style-type: none"> <li>Spare Parts</li> <li>Proper number of spares of wind turbine parts for maintenance</li> </ul>	1	-	-	-	In accordance with customer's requirement and MHI recommendation, they shall be supplied and quoted.
26	<ul style="list-style-type: none"> <li>Special Parts for Maintenance</li> <li>- Generator centering tool</li> <li>- Accumulator gas charging tool</li> </ul>	1	MHI	MHI	-	MHI will deliver one (1) set of the special parts for 15MW total units.
27	<ul style="list-style-type: none"> <li>Secondary material for erection and construction</li> <li>-General tools(Torque wrench and pumps, Spanner, Hammer etc)</li> <li>-Hay, skid and other protecting materials</li> <li>-Lock-tight, moricoat and other applications</li> </ul>	-	C	C	-	



WTG Ex-A Specification for WT 060210.doc

## 5. PERFORMANCE CURVE

Standard power curve is shown as below, assumed the air density to be 1.225kg/m<sup>3</sup>.(to be revised after Site Designation)

**Table 1 Standard Power Curve for MWT62/1000A\_69m**

Wind Speed At Hub height (m/s)	Air Density =1.225	Wind Speed At Hub height (m/s)	Air Density =1.225
	Output Power (kW)		Output Power (kW)
Cut-in 3.0	0.0	14.5	1000.0
3.5	1.0	15.0	1000.0
4.0	6.0	15.5	1000.0
4.5	24.0	16.0	1000.0
5.0	54.0	16.5	1000.0
5.5	93.0	17.0	1000.0
6.0	140.0	17.5	1000.0
6.5	194.0	18.0	1000.0
7.0	254.0	18.5	1000.0
7.5	321.0	19.0	1000.0
8.0	396.0	19.5	1000.0
8.5	477.0	20.0	1000.0
9.0	564.0	20.5	1000.0
9.5	653.0	21.0	1000.0
10.0	741.0	21.5	1000.0
10.5	821.0	22.0	1000.0
11.0	888.0	22.5	1000.0
11.5	940.0	23.0	1000.0
12.0	976.0	23.5	1000.0
Rated 12.5	1000.0	24.0	1000.0
13.0	1000.0	24.5	1000.0
13.5	1000.0	25.0	1000.0
14.0	1000.0		

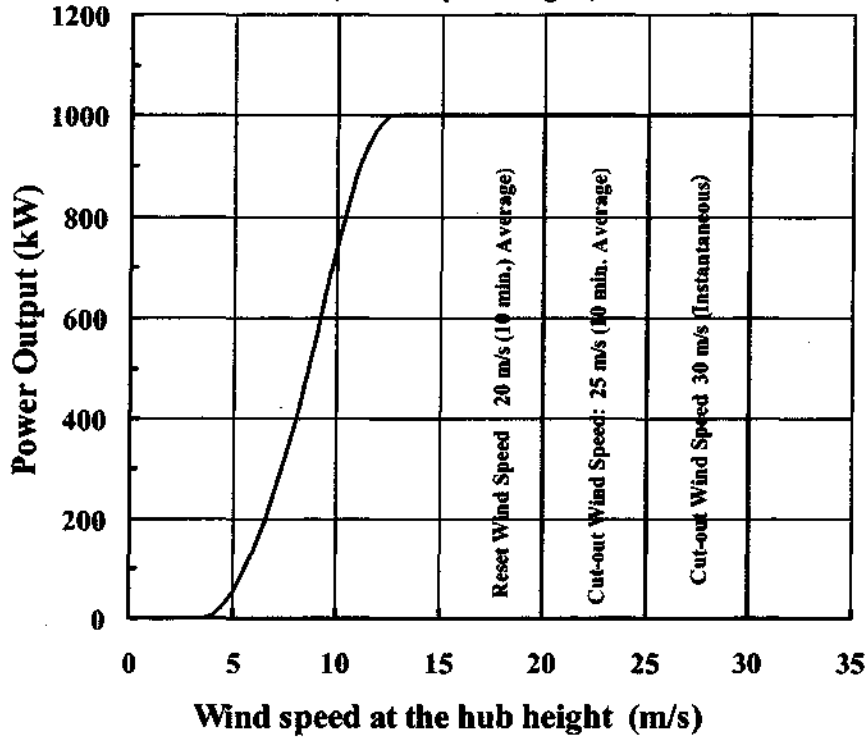
### Remarks ;

The following assumptions and conditions are made solely for the purpose of expressing the relationship between wind speed and kilowatt production and do not constitute representations or warranties of actual conditions.

- ◆ The above data are valid at the 10minutes average wind speed data measured at the hub height only.
- ◆ The output is measured at the control panel.
- ◆ For purposes of computing power output with respect to the power curve, the turbulence intensity is assumed to be 10%.
- ◆ This power curve assumes flat ground and the absence of any external factor that could affect the force or direction of wind or the transmission of electrical energy (for example, array loss, topography, etc.).
- ◆ This power curve and the turbine specifications assume site wind condition on or below IEC Class IIA standards.

## MWT-1000A POWER CURVE

(Air Density : 1.225 kg/m<sup>3</sup>)

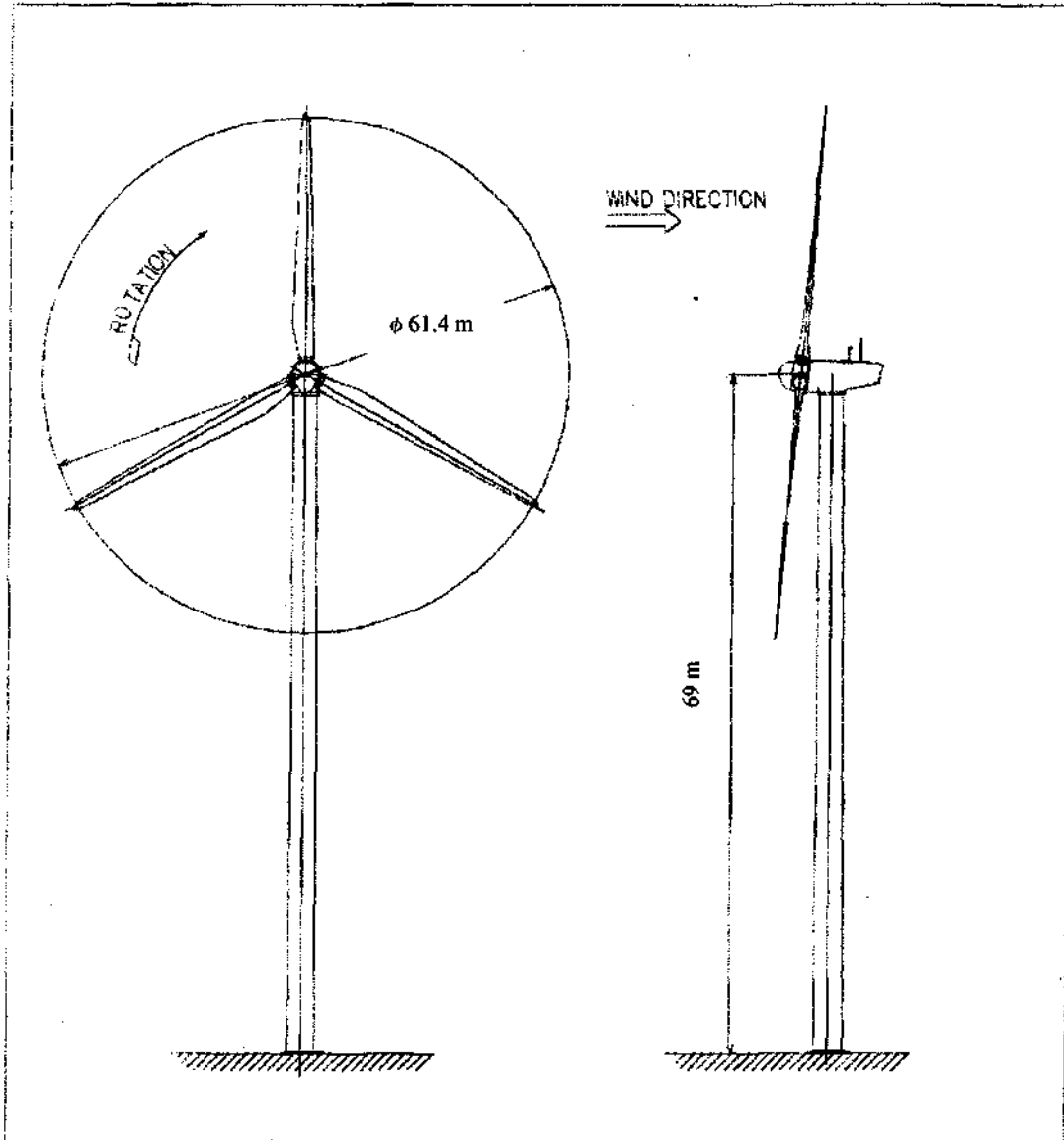


### Remarks.

The following assumptions and conditions are made solely for the purpose of expressing the relationship between wind speed and kilowatt production and do not constitute representations or warranties of actual conditions.

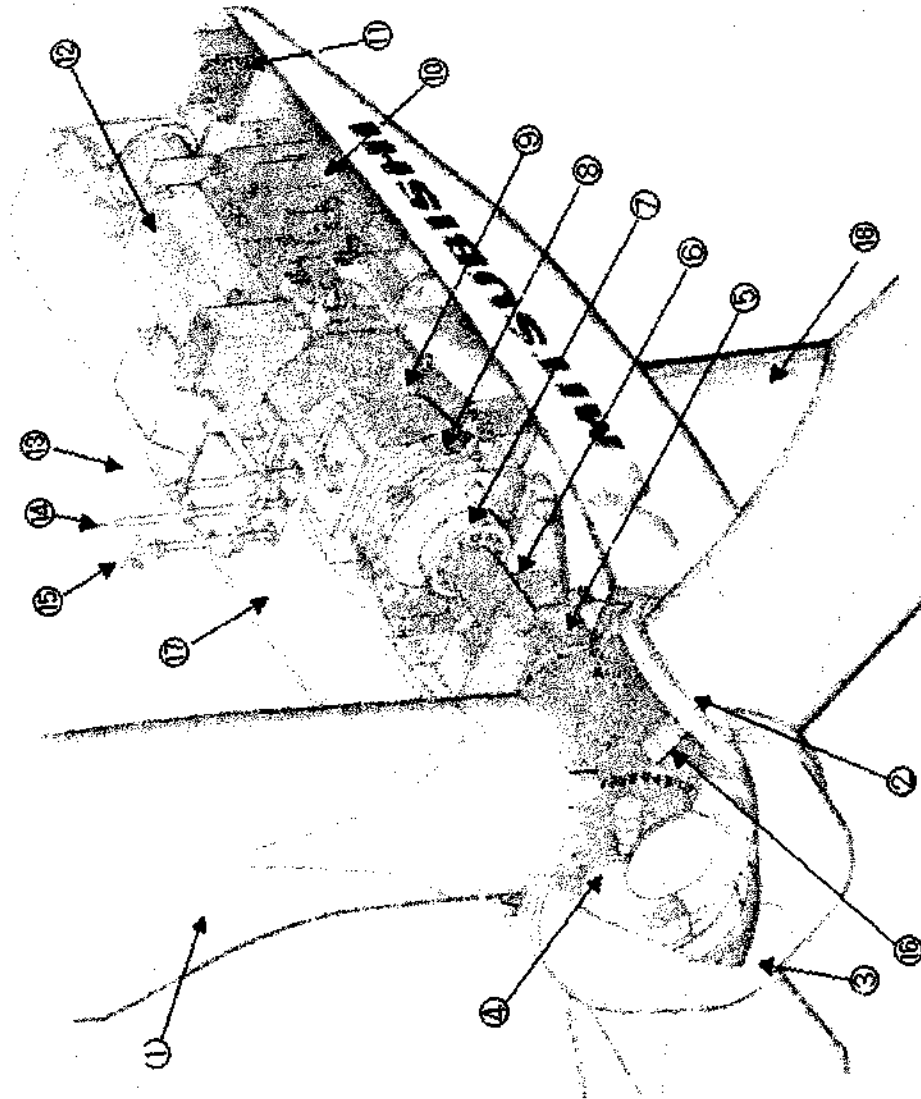
- ◆ The above data are valid at the 10 minutes average wind speed data measured at the hub height only.
- ◆ The output is measured at the control panel.
- ◆ For purposes of computing power output with respect to the power curve, the turbulence intensity is assumed to be 10%.
- ◆ This power curve assumes flat ground and the absence of any external factor that could affect the force or direction of wind or the transmission of electrical energy (for example, array loss, topography, etc.).
- ◆ This power curve and the turbine specifications assume site wind condition on or below IEC Class IIA standards.

**Attachment 1 OUTLINE OF MWT62/1000A**

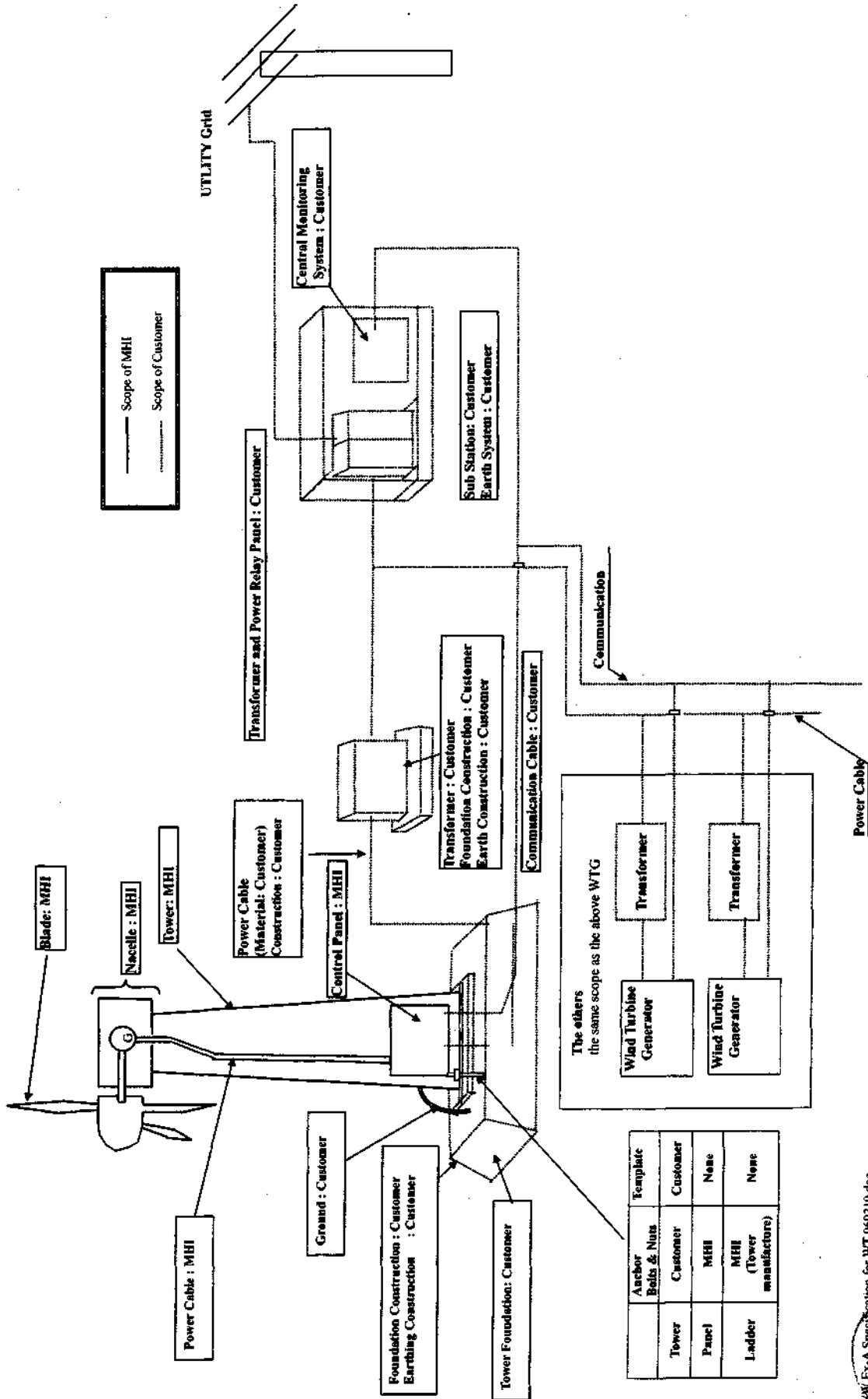


**Attachment 2 GENERAL ARRANGEMENT OF MWT62/1000**

- Parts**
- ① Blade
  - ② Blade Bearing
  - ③ Front Capsule
  - ④ Rotor Head
  - ⑤ Main Bearing
  - ⑥ Main Shaft
  - ⑦ Coupling (Low Speed)
  - ⑧ Gear Box
  - ⑨ Coupling (High Speed)
  - ⑩ Hydraulic Unit
  - ⑪ L.O. Cooler (with Fan)
  - ⑫ Generator
  - ⑬ Wind Vane
  - ⑭ Lightning Rod
  - ⑮ Anemometer
  - ⑯ Hydraulic Pitch Link System
  - ⑰ Nacelle
  - ⑱ Tower



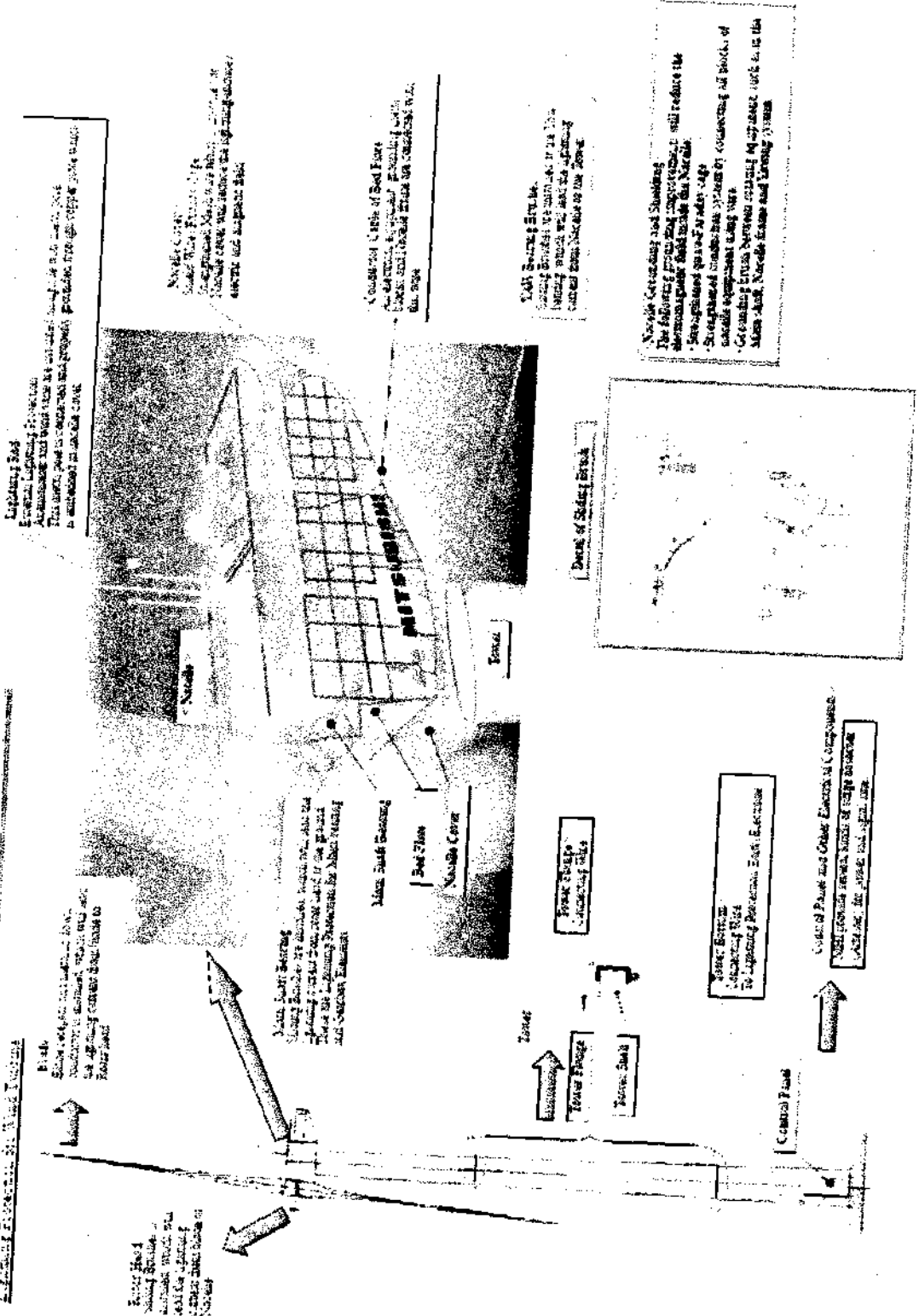
**Attachment 3 Division of Responsibilities between MHI and Customer**



	Anchor Beds & Nuts	Example
Tower	Customer	Customer
Panel	MHI	None
Ladder	MHI (Tower manufacturer)	None

**Attachment-4 Lightning protection for Wind turbine**

Lightning Protection for Wind Turbine



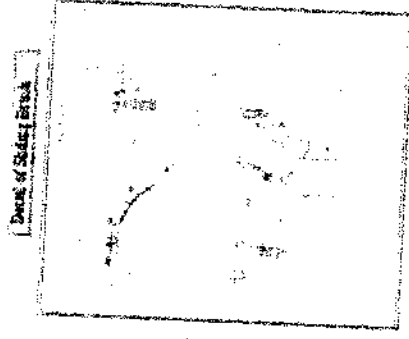
**Lightning Rod**  
 External Lightning Protection  
 The lightning rod is connected to the ground through a lightning rod cable to discharge the lightning energy.

**Nacelle Cover**  
 Nacelle Cover Protection  
 The nacelle cover is made of aluminum alloy and is connected to the ground through a lightning rod cable to discharge the lightning energy.

**Control Cable of Bed Plate**  
 The control cable of the bed plate is connected to the ground through a lightning rod cable to discharge the lightning energy.

**Main Shaft Bearing**  
 Voltage Surge Protection  
 The main shaft bearing is connected to the ground through a lightning rod cable to discharge the lightning energy.

**Nacelle Covering and Shielding**  
 The following program for covering and shielding will reduce the electromagnetic field inside the nacelle.  
 • Strengthened ground wire system  
 • Grounding system between rotating part and tower  
 • Shielding system between rotating part and tower



**Prevent Surge**  
 Preventing surge

**Control Cable**  
 Control Cable and Other Elements of Components  
 The control cable and other elements of components are connected to the ground through a lightning rod cable to discharge the lightning energy.

*[Handwritten signature]*